



Designation: D7917 – 14 (Reapproved 2018)

Standard Practice for Inductive Wear Debris Sensors in Gearbox and Drivetrain Applications¹

This standard is issued under the fixed designation D7917; the number immediately following the designation indicates the year of original adoption or, in the case of revision, the year of last revision. A number in parentheses indicates the year of last reapproval. A superscript epsilon (ϵ) indicates an editorial change since the last revision or reapproval.

INTRODUCTION

Wear debris sensors, employing inductive sensing technologies (1, 2),² are able to quantify wear debris to classify size and material composition (ferrous/non-ferrous) of metallic debris found in lubricating oil as a consequence of wear. Initial applications have been largely confined to industrial aero-derivative and aircraft gas turbine engine monitoring installations where the failure of high speed ball and roller bearings results in significant secondary damage (2, 3). With an almost exponential growth in the wind turbine industry, one engineering issue still to be resolved is the unacceptable gearbox failure rate (4). Wear debris sensors can play an important role in understanding the varied bearing failure modes observed. There are thousands of inductive sensors operating in wind turbines and other gearbox and drivetrain applications accruing millions of operational hours. While it is generally accepted that these sensors provide early warning of abnormal condition, the industry will benefit from a standard practice for data usage and interpretation.

1. Scope

1.1 This practice covers the minimum requirements for an online inductive sensor system to monitor ferromagnetic and non-ferromagnetic metallic wear debris present in in-service lubricating fluids residing in gearboxes and drivetrains.

1.2 Metallic wear debris considered in this practice can range in size from 40 μm to greater than 1000 μm of equivalent spherical diameter (ESD).

1.3 This practice is suitable for use with the following lubricants: industrial gear oils, petroleum crankcase oils, polyalkylene glycol, polyol esters, and phosphate esters.

1.4 This practice is for metallic wear debris detection, not oil cleanliness.

1.5 The values stated in SI units are to be regarded as standard. No other units of measurement are included in this standard.

1.5.1 *Exception*—Subsection 7.7 uses “G’s”.

¹ This practice is under the jurisdiction of ASTM Committee D02 on Petroleum Products, Liquid Fuels, and Lubricants and is the direct responsibility of Subcommittee D02.96.07 on Integrated Testers, Instrumentation Techniques for In-Service Lubricants.

Current edition approved Oct. 1, 2018. Published November 2018. Originally approved in 2014. Last previous edition approved in 2014 as D7917 – 14. DOI: 10.1520/D7917-14R18.

² The boldface numbers in parentheses refer to the list of references at the end of this standard.

1.6 *This standard does not purport to address all of the safety concerns, if any, associated with its use. It is the responsibility of the user of this standard to establish appropriate safety, health, and environmental practices and determine the applicability of regulatory limitations prior to use.*

1.7 *This international standard was developed in accordance with internationally recognized principles on standardization established in the Decision on Principles for the Development of International Standards, Guides and Recommendations issued by the World Trade Organization Technical Barriers to Trade (TBT) Committee.*

2. Referenced Documents

2.1 *ASTM Standards:*³

D4175 *Terminology Relating to Petroleum Products, Liquid Fuels, and Lubricants*

D7669 *Guide for Practical Lubricant Condition Data Trend Analysis*

D7685 *Practice for In-Line, Full Flow, Inductive Sensor for Ferromagnetic and Non-ferromagnetic Wear Debris Determination and Diagnostics for Aero-Derivative and Aircraft Gas Turbine Engine Bearings*

D7720 *Guide for Statistically Evaluating Measurand Alarm Limits when Using Oil Analysis to Monitor Equipment*

³ For referenced ASTM standards, visit the ASTM website, www.astm.org, or contact ASTM Customer Service at service@astm.org. For *Annual Book of ASTM Standards* volume information, refer to the standard's Document Summary page on the ASTM website.

and Oil for Fitness and Contamination
G40 Terminology Relating to Wear and Erosion

2.2 ISO Standards:⁴

ISO/TC 108 N 605 Terminology for the Field of Condition
Monitoring and Diagnostics of Machines

3. Terminology

3.1 Definitions:

3.1.1 *condition monitoring, n*—a field of technical activity in which selected physical parameters associated with an operating machine are periodically or continuously sensed, measured, and recorded for the interim purpose of reducing, analyzing, comparing, and displaying the data and information so obtained, and for the ultimate purpose of using interim result to support decisions related to the operation and maintenance of the machine.

3.1.2 *equivalent spherical diameter (ESD), n*—the equivalent spherical diameter of an irregularly shaped object is the diameter of a sphere of equivalent volume.

3.1.2.1 *Discussion*—Metallic particles used to test and calibrate inductive wear debris sensors are manufactured as spheres. A range of diameters, from smallest to largest sizes investigated, is utilized to vet the sensor's capabilities and calibrate it. Spheres ranging from ~40 μm to 1000 μm are used for this exercise. *In vivo* ferrous and non-ferrous debris will rarely be spherical; however all particles detected and counted are deemed to be spheres for reporting purposes, with the reasonable assumption that the ESD mass will be close to the equivalent mass of the non-spherical particle measured.

3.1.3 *inductive debris sensor, n*—a device that creates an electromagnetic field as a medium to permit the detection and measurement of metallic wear debris.

3.1.3.1 *Discussion*—A device that detects metallic wear debris that causes fluctuations of the magnetic field. A device that generates a signal proportional to the size and presence of metallic wear debris with respect to time.

3.1.4 *machinery health, n*—a qualitative expression of the operational status of a machine subcomponent, component, or entire machine, used to communicate maintenance and operational recommendations or requirements in order to continue operation, schedule maintenance, or take immediate maintenance action.

3.1.5 *metallic wear debris, n*—in tribology, metallic particles that have become detached in wear or erosion processes.

3.1.5.1 *Discussion*—This practice declares 40 μm ESD as the lower limit of detection for inductive debris sensors. This has not been shown to be a limiting factor for this real-time monitoring.

3.1.6 *online sensor, n*—a monitoring device that can be installed fully in-line or in a bypass loop with the lubrication system.

3.1.6.1 *Discussion*—In the former case, the sensor should be capable of allowing the full flow of the lubrication fluid to

travel through unimpeded. In the latter case of the bypass loop, care must be taken to ensure a representative sample is flowing through the sensor.

3.2 *trend analysis, n*—monitoring of the level and rate of change over operating time of measured parameters.

4. Summary of Practice

4.1 An inductive sensor is fitted either in-line with, or in a bypass loop of, the lubricant flow. The sensor locations and connection method chosen will depend on the individual installation but should supply a representative portion of the oil flow and debris from the gearbox or drivetrain through the sensor before any filtration. The minimum requirements of a system are the detection and counting of ferrous and non-ferrous metallic wear debris carried in the oil flow. Counts are often accumulated in one or more material channels for binned size ranges. Bin size ranges can be configurable, as are the number of bins. Example options are one to five bins, spanning the range from an equivalent sphere diameter (ESD) of 40 μm to greater than 1000 μm in the case of ferromagnetic debris, or from 135 μm to greater than 1000 μm for non-ferromagnetic debris. Bins can be extended to as many as 20 for finer granularity and precision in particle size or mass estimates. The upper size limits are determined by signal saturation of the particular sensors. Estimates of cumulated debris counts and/or mass may also be calculated as a function of time. Correlation of the rate of change of accumulated counts and/or mass provides information on the health of the machinery and can be used to inform planning decisions on maintenance schedules or estimate remaining useful life (RUL).

5. Significance and Use

5.1 This practice is intended for the application of online, full-flow, or slip-stream sampling of wear debris via inductive sensors for gearbox and drivetrain applications.

5.2 Periodic sampling and analysis of lubricants have long been used as a means to determine overall machinery health. The implementation of smaller oil filter pore sizes for machinery has reduced the effectiveness of sampled oil analysis for determining abnormal wear prior to severe damage. In addition, sampled oil analysis for equipment that is remote or otherwise difficult to monitor or access is not always sufficient or practical. For these machinery systems, in-line wear debris sensors can be very useful to provide real-time and near-real-time condition monitoring data.

5.3 Online inductive debris sensors have demonstrated the capability to detect and quantify both ferromagnetic and non-ferromagnetic metallic wear debris (1, 2). These sensors record metallic wear debris according to size, count, and type (ferromagnetic or non-ferromagnetic). Sensors can be fitted to virtually any lubricating system. The sensors are particularly effective for the protection of rolling element bearings and gears in critical machine applications. Bearings are key elements in machines since their failure often leads to significant secondary damage that can adversely affect safety, operational availability, operational/maintenance costs, or combinations thereof.

⁴ Available from American National Standards Institute (ANSI), 25 W. 43rd St., 4th Floor, New York, NY 10036, <http://www.ansi.org>.

5.4 The key advantage of online metallic debris sensors is the ability to detect early bearing and gear damage and to quantify the severity of damage and rate of progression toward failure. Sensor capabilities are summarized as follows:

- 5.4.1 Can detect both ferromagnetic and non-ferromagnetic metallic wear debris.
- 5.4.2 Can detect 95 % or more of metallic wear debris above some minimum particle size threshold.
- 5.4.3 Can count and size wear debris detected.
- 5.4.4 Can provide total mass loss.

NOTE 1—Mass is an inferred value which assumes the debris is spherical and made of a specific grade of steel.

5.4.5 Can provide algorithms for RUL warnings and limits.

5.5 Fig. 1 (5) presents a widely used diagram to describe the progress of metallic wear debris release from normal to catastrophic failure. This figure summarizes metallic wear debris observations from all the different wear modes that can range from polishing, rubbing, abrasion, adhesion, grinding, scoring, pitting, spalling, and so forth. As mentioned in numerous references (6-12), the predominant failure mode of rolling element bearings is spalling or macro pitting. When a bearing spalls, the contact stresses increase and cause more fatigue cracks to form within the bearing subsurface material. The propagation of existing subsurface cracks and creation of new subsurface cracks causes ongoing deterioration of the material that causes it to become a roughened contact surface as illustrated in Fig. 2. This deterioration process produces large numbers of metallic wear debris with a typical size range from 40 μm to 1000 μm or greater. Thus, rotating machines, such as wind turbine gearboxes, which contain rolling element bearings and gears made from hard steel, tend to produce this kind of large metallic wear debris that eventually leads to failure of the machines.

5.6 Online wear debris monitoring provides a more reliable and timely indication of bearing distress for a number of reasons.

5.6.1 Firstly, bearing failures on rotating machines tend to occur as events often without sufficient warning and could be missed by means of only periodic inspections or data sampling observations.

5.6.2 Secondly, because larger wear metallic debris particles are being detected, there is a lower probability of false



FIG. 2 Typical Bearing Spall

indication from the normal rubbing wear that will be associated with smaller particles. And because wear metal debris particles are larger than the filter media, detections are time correlated to wear events and not obscured by unfiltered small particles.

5.6.3 Thirdly, build or residual debris, from manufacturing or maintenance actions, can be differentiated from actual damage debris because the cumulative debris counts recorded due to the former tend to decrease, while those due to the latter tend to increase.

5.6.4 Fourthly, bearing failure tests have shown that wear debris size distribution is independent of bearing size (2, 3, 6, 12, 13).

6. Interferences

6.1 In order to avoid wear debris counts being invalid due to possible noise from drivetrain application environmental influences such as excessive vibration and loads, unusually high electromagnetic interferences, abnormally low oil temperatures, and unusual oil pressure pulsations, users should select a sensor having specifications that can cope with their possible environmental influences and have it installed and set to work in accordance with the sensor manufacturer’s recommendations.

7. Apparatus

7.1 Inductive wear debris sensors incorporate a magnetic coil assembly surrounding a non-magnetic tube through which either full or partial oil flow from the machinery or equipment is passed. The coil assembly concept consists of one or more sensing and excitation coils and is the heart of the sensor as shown in Fig. 3. The outer excitation coils establish an alternating magnetic field and the inner sense coils respond to the disturbance of this alternating current magnetic field due to the passage of a metallic debris particle. As the mechanism by which the metallic particle interacts with the magnetic field is different in the two material classes, magnetic susceptibility in the case of ferrous debris and electrical conductivity (eddy currents) in the case of non-ferrous debris, an inherent reversal in the signal phase provides clear discrimination (Fig. 4). It is important to note, however, that some single channel inductive wear debris sensors detect a reversal in signal amplitude or

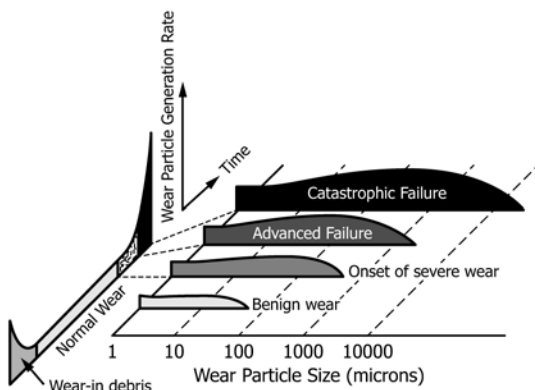

FIG. 1 Wear Debris Characterization

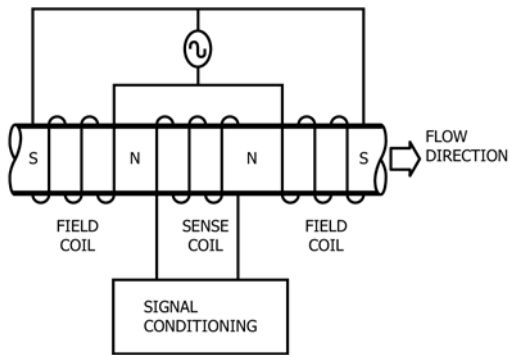

FIG. 3 Sensor Major Components

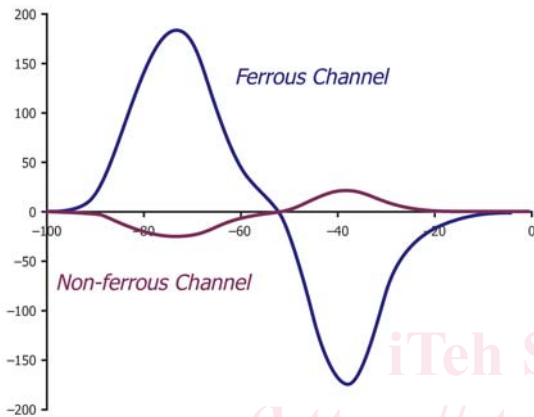

FIG. 4 Representative Signal Trace

7.2.2 If the sensor bore does not restrict oil flow and provides sufficient sensitivity, a simple in-line full-flow arrangement is available (14). Note that the sensor should be placed between the gearbox, or machinery to be monitored, and the main filtration unit to allow maximum debris detection before removal by the filter.

7.2.3 Where the oil flow is too high for the sensor bore or the oil line too large, a bypass loop is a viable option. Concerns over the ability for such an arrangement to deliver a representative sample of oil debris to the sensor can be alleviated by proper design. Fig. 5 shows a schematic of such a bypass loop. Again, the sensor should be positioned before the filtration system, and it is good practice to provide isolating valves in the loop to allow for servicing tasks. Flow meters positioned upstream of the sensor and within the loop provide confidence in adequate flow rates. The takeoff and return points should be angled as shown in Fig. 5 to encourage flow into the sensor. It may also be advantageous to incorporate a small baffle within the main oil pipe just prior to and opposite from the takeoff point to provide a small degree of turbulence with the oil stream and ensure an even mixing of wear debris. A further consideration is the operational flow rate and stability within the main oil pipe. If the main flow is low but mostly constant, a gate or throttle valve can be incorporated as shown to ensure a suitable flow rate within the sensor loop. Otherwise, if the

direction to identify non-ferrous as opposed to monitoring phase angle between output channels.

7.1.1 Moreover, the size of the signal is related to a characteristic “size” of the particle diameter in the case of nearly spherical debris and an equivalent spherical diameter in the case of other morphologies, allowing binning and classification to be readily reported. There are orientation effects in the case of highly asymmetric particles on the signal size and, likewise, the precise material composition can also influence signal magnitude by some degree. Nevertheless, such sensors are able to provide accurate and consistent real-time diagnostic information to monitor critical gearbox and drivetrain systems.

7.2 Sensor Positioning:

7.2.1 Many gearboxes have an external filtration loop to remove wear debris or contamination. In such instances, the sensor should be placed either prior to the filter on the main filtration loop or in a kidney loop, such that it sees a representative sampling of the lubricant. Either placement geometry is valid as long as the flow is not compromised by the sensor bore diameter. This is the case for oil pipe diameters equal to or less than the sensor bore. Increasing the bore diameter in the sensor to allow for faster flow rates, however, can be counterproductive as this impacts the sensitivity of the sensor to smaller sized debris. Note also that the sensitivity is affected by debris speed through the sensor and this is related to oil flow rate. Manufacturers should provide minimum and maximum flow rates for the stated bore sizes. Their guidelines should be adhered to for optimum performance.

BYPASS LOOP OPTION
USED WHEN FLOW RATE IS TOO HIGH FOR SENSOR

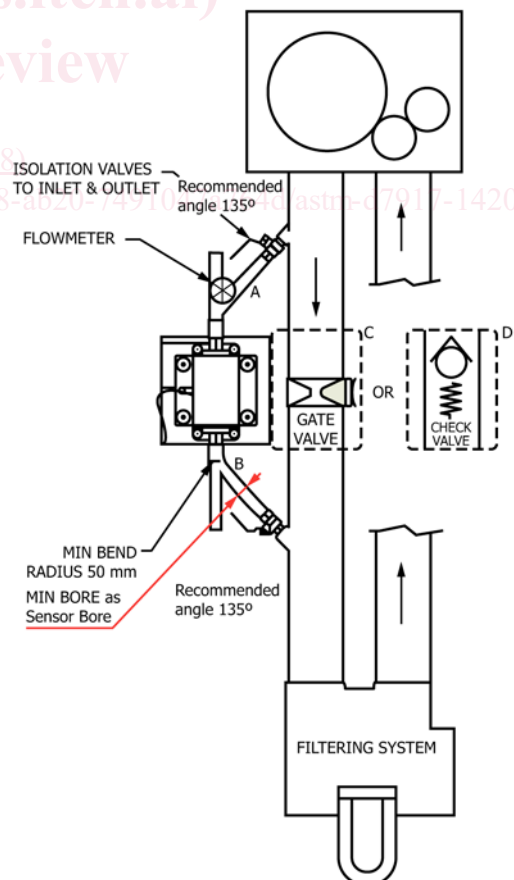

FIG. 5 Bypass Loop Option

main flow is likely to be variable, a check valve can be substituted with a cracking pressure that ensures that the check valve is fully open before the sensor flow rate is exceeded.

7.3 Dynamic Range—The dynamic range depends on the nominal line diameter, spanning the range from an equivalent sphere diameter (ESD) of 40 μm to greater than 1000 μm in the case of ferromagnetic debris, or from 135 μm to greater than 1000 μm for non-ferromagnetic debris.

7.4 Operating Temperature Range—Sensors may be mounted in harsh environments, though exact temperature ranges vary depending on the manufacturer. Minimum and maximum ambient temperatures range from as low as $-40\text{ }^{\circ}\text{C}$ to as high as $+85\text{ }^{\circ}\text{C}$, with oil temperatures ranging from $-40\text{ }^{\circ}\text{C}$ to $+85\text{ }^{\circ}\text{C}$.

7.5 Operating Pressure—Sensors can be installed directly into the fluid line without adversely affecting the lubrication system. The allowable maximum operating pressure depends on the bore size of the sensor and manufacturer with maximum operating pressures as high as 2000 kPa.

7.6 Flow Rate—Sensors are commercially available that can accommodate flow rate ranges from 0.5 L/min to 1000 L/min. The flow rate through a sensor in a specific application should be selected in accordance with the lubrication system design and the sensor manufacturers' specifications.

7.7 Vibration Sensitivity—Sensors are commercially available that can withstand vibration levels up to 15 G's at 50 Hz to 300 Hz ($1\text{ G} = 9.813\text{ m/s}^2$). Sensors should be installed in a vibration environment that is in accordance with the manufacturers specifications.

7.8 Power Requirements—Power requirements can vary by manufacturer, typically 12 V to 30 V DC at less than 5 W.

8. Calibration

8.1 A single ferrous or other metal particle is embedded in an epoxy/nylon wand that can be passed back and forth through the sensor bore, isolated, and measured using an oscilloscope to monitor voltage generation from the particle's disturbance of the magnetic field. This procedure was used to verify detection of ferrous particles with diameter as small as 40 μm and non-ferrous particles as small as 135 μm . Inductive wear debris sensors are robust, easy to use, and require no field calibration or periodic maintenance.

9. Data Processing

9.1 Numerous data points are provided from which diagnostic information can be interpreted. Health indices can be set on total mass detected, total ferrous particles, total non-ferrous particles, total mass per time, and metallic concentration. Alarm limits and trends can be set on these values.

9.2 Guidance for statistically rendering data to establish limits and trends is provided in Guides **D7669** and **D7720**, and in Practice **D7685**.

9.3 Practice **D7685** provides detailed discussion and specific guidance and formulas for rolling element bearings.

9.4 **Appendix X2** provides detailed discussion and specific guidance and formulas for generating wind turbine gearbox alarm and warning limits.

9.5 **Appendix X4** provides detailed discussion and specific guidance and formulas for setting alarm and warning limits for any gearbox application.

10. Report

10.1 The particle sensor will detect and count individual metallic particles. A history is kept on the particle count.

10.1.1 Optional Features:

10.1.1.1 The size of the particles can be determined. Each time a metallic particle passes through the bore, it is classified by its size and metallurgical composition.

10.1.1.2 Alarms can be set based on particles/minute, particles/hour, any bin, total mass, total counts, and so forth.

10.1.1.3 Cumulative counts or mass of debris can be plotted.

10.1.1.4 Mass/time can be plotted.

10.1.1.5 Metallic wear debris concentration can be plotted.

10.2 **Appendix X2** provides detailed discussion and specific guidance for interpreting and analyzing wind turbine gearbox inductive oil debris cumulative counts.

10.3 **Appendix X4** provides detailed discussion and specific guidance for interpreting and analyzing inductive oil debris total particle mass, mass detected per time interval, and mass concentration per time interval.

11. Keywords

11.1 bearings; gears; online metallic debris sensors; online oil debris sensors; sensors; wear; wind turbines

APPENDIXES

(Nonmandatory Information)

X1. DISCUSSION OF ALARM AND WARNING LIMITS FOR DATA ANALYSIS BEST PRACTICES

X1.1 The following appendices describe two distinct ways in which alarm and warning limits are generated.

X1.1.1 The first practice is described fully in Appendix X2, and is based on the total volume of ferromagnetic wear debris material removed from a rolling element bearing or gear over time. This type of warning or alarm limit is in units of cumulative particle counts over time as a measure of the total wear scar equivalent damage and there is no need for the particle size distribution, or relevance thereof, to be taken into consideration. All that is required is input of the bearing geometry as outlined in Appendix X2.

X1.1.2 The second practice is described in Appendix X4 and monitors the wear generation rates of an asset over time, in comparison to statistical limits from a population of similar assets. This type of limit is in units of either metallic particle mass per time window or metallic particle concentration and uses particle mass estimates for each observed particle or based

on the estimated mass for a given bin range. Taking particle mass into consideration allows for the creation of a unified condition indicator that takes advantage of the technologies' particle sizing estimates to determine the significance of small particle events and large particle events. The non-cumulative nature of concentration and mass per time estimates also allow for isolation of wear generation event to specific periods of time and modes of operation. Additionally, non-cumulative methods are not dependent upon knowledge of the prior operating history of the asset.

X1.1.3 The wear debris sensor manufacturer can provide initial alarm and warning limit values based on previous experience from similar applications.

X1.1.4 Selection of one of these alarm limit practices should be done based on the application and through consultation with the sensor manufacturer.

X2. GENERATING ALARM AND WARNING LIMITS BASED ON CUMULATIVE PARTICLE COUNTING FOR WIND TURBINE GEARBOXES⁵

X2.1 From individual bearing and gear component tests, it has been shown that oil debris monitoring is effective at detecting early damage and the progression of damage in bearings and gears, at quantifying damage severity by means of accumulated metallic debris particle counts, and determining that damage progression rate is affected by speed and load (2, 3, 6, 12, 13, 15, 16, 17-19).

X2.2 In order to apply a single oil debris sensor for condition monitoring of an entire wind turbine gearbox as shown in Fig. X2.1, a number of key considerations are summarized as follows:

X2.2.1 A multi-stage wind turbine gearbox will have many bearings and gears.

X2.2.2 During operation, wind turbine gearbox loads are highly variable, given that the input wind speeds are variable (that is, power varies as the cube of wind speed).

⁵ Formula applies only to sensor from GasTOPS Ltd, 1011 Polytek St, Ottawa, Ontario K1J 9J3.

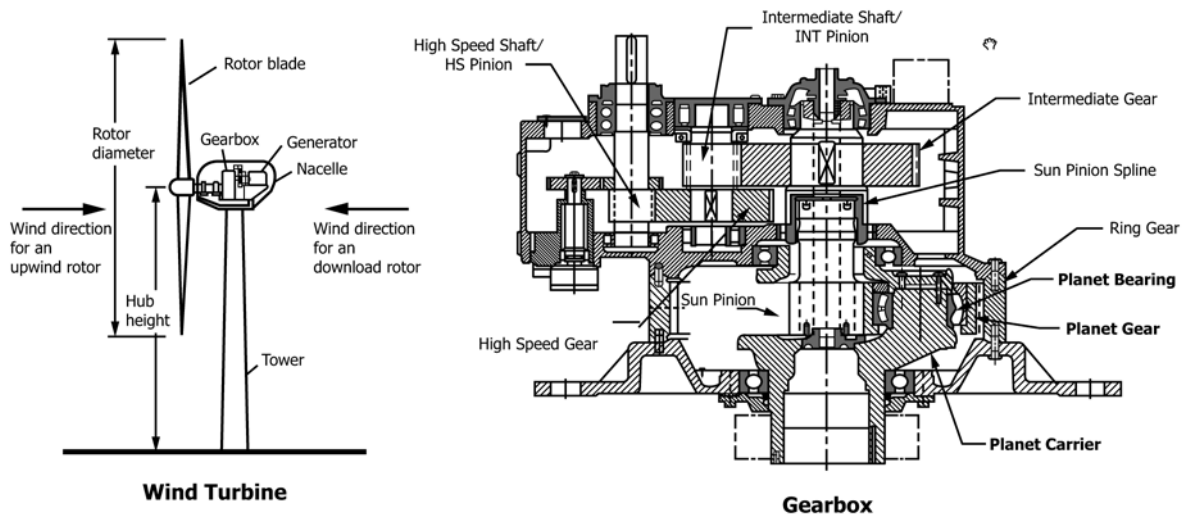

FIG. X2.1 Wind Turbine Gearbox Overview