



Designation: ~~D2718 – 00 (Reapproved 2011)~~^{ε1} D2718 – 18

Standard Test Methods for Structural Panels in Planar Shear (Rolling Shear)¹

This standard is issued under the fixed designation D2718; the number immediately following the designation indicates the year of original adoption or, in the case of revision, the year of last revision. A number in parentheses indicates the year of last reapproval. A superscript epsilon (ϵ) indicates an editorial change since the last revision or reapproval.

^{ε1} NOTE—~~Eq 2 and Eq 4 were corrected editorially in April 2017.~~

1. Scope

1.1 These test methods determine the shear properties of structural panels associated with shear distortion of the planes parallel to the edge planes of the panels. Both shear strength and modulus of rigidity may be determined. Primarily, the tests measure the planar shear (rolling shear) strength developed in the plane of the panel.

1.2 Structural panels in use ~~include plywood, waferboard, oriented strand board,~~ include, but are not limited to, structural plywood, oriented strand board (OSB), and composites of veneer and of wood-based layers.

1.3 Two test methods are included:

1.3.1 *Test Method A*—Planar shear loaded by plates.

1.3.2 *Test Method B*—Planar shear induced by five-point bending.

1.3.3 The choice of method will be dictated by the purpose of the test and equipment available.

1.3.4 *Test Method A, Planar Shear Loaded by Plates*—This test method uses a rectangular panel section adhered between steel plates with protruding knife edges to create load at the panel faces. This test method has been used to develop shear properties of plywood and oriented strand board for the purpose of confirming design values. This test method does not produce pure shear, but the specimen length is prescribed so that the secondary stresses have a minimum effect. The method determines shear strength and modulus of rigidity.

1.3.5 *Test Method B, Planar Shear Induced by Five-Point Bending*—Planar shear stress is induced on the panel while loaded in bending using two continuous spans. This test method determines planar shear strength consistent with panel applications under transverse loading. This test method is able to determine shear strength at any moisture condition.

1.4 *This standard does not purport to address all of the safety concerns, if any, associated with its use. It is the responsibility of the user of this standard to establish appropriate ~~safety~~ safety, health, and health environmental practices and determine the applicability of regulatory limitations prior to use.*

1.5 *This international standard was developed in accordance with internationally recognized principles on standardization established in the Decision on Principles for the Development of International Standards, Guides and Recommendations issued by the World Trade Organization Technical Barriers to Trade (TBT) Committee.*

2. Referenced Documents

2.1 *ASTM Standards:*²

[D2395 Test Methods for Density and Specific Gravity \(Relative Density\) of Wood and Wood-Based Materials](#)

[D4442 Test Methods for Direct Moisture Content Measurement of Wood and Wood-Based Materials](#)

3. Significance and Use

3.1 Planar shear (rolling shear) characteristics of structural panels determined by these test methods are essential for the rigorous design of various glued wood-panel structural components, such as box beams, folded plate roofs, and stressed skin panels. Planar shear also may govern the design at low span-depth ratios encountered in floors subjected to high concentrated loads, concrete forms at high pouring pressures, and bulk storage structures.

¹ This test method is under the jurisdiction of ASTM Committee [D07](#) on Wood and is the direct responsibility of Subcommittee [D07.03](#) on Panel Products. Current edition approved ~~Nov. 1, 2011~~ Nov. 1, 2018. Published ~~November 2011~~ November 2018. Originally approved in 1969. Last previous edition approved in ~~2000~~ 2011 as ~~D2718 – 00 (2006)~~ (2011)^{ε1}. DOI: ~~10.1520/D2718-00R11E01~~ 10.1520/D2718-18.

² For referenced ASTM standards, visit the ASTM website, www.astm.org, or contact ASTM Customer Service at service@astm.org. For *Annual Book of ASTM Standards* volume information, refer to the standard's Document Summary page on the ASTM website.

3.2 The modulus of rigidity determined from Test Method A is a composite of the entire specimen acting as a unit. For plywood panels for which the ratio between the shear moduli of the plies with grain oriented parallel and perpendicular to the shear forces is known, the rolling shear modulus of the perpendicular plies can be calculated.

3.3 Veneer produced by slicing or rotary peeling may contain fine checks or separations parallel to the grain on the knife side of the veneer that are produced as the knife is forced through the wood. These checks are termed “knife checks” to distinguish them from occasional checks that may be formed on the opposite side of the veneer by forces at the compression bar, and from checks caused by drying. Knife checks can have a significant effect on rolling shear properties in plywood panels and may be of significance in other veneer containing panels. Test Method A requires (when applicable) the testing of matching specimens having knife checks oriented both open and closed wherever possible (see Fig. 1).

3.4 To control or define other variables influencing rolling shear, these test methods require determination of moisture content, specific gravity, and elapsed time-to-failure. Conditioning of test material in controlled atmospheres, determination of depth of knife checks (when applicable), and determination of percent of wood and plywood glue-line failure (when applicable) are recommended.

4. Control of Moisture Content

4.1 The structural panel samples to be tested at specific moisture contents or equilibrium relative humidities shall be conditioned to approximately constant weight in controlled atmospheric conditions before gluing to plates. For approximating moisture conditions of structural panel used under dry conditions a relative humidity of $65 \pm 2\%$ at a temperature of $68 \pm 6^\circ\text{F}$ ($20 \pm 3^\circ\text{C}$) is recommended. Specimens—When using Test Method A, specimens shall be tested without undue delay after the adhesive is cured. Testing in similarly controlled atmospheres is recommended wherever possible.

Test Method A—Planar Shear Loaded by Plates

5. Scope

5.1 The specimen having the form of a rectangular flat plate is bonded between steel plates beveled at opposite ends of the specimen to provide knife edges for loading the plate at the face bonded to the specimen. The knife edges project beyond the ends of the specimen. This test method is conducted by loading the knife edges in compression at a uniform rate while a suitable gage measures slip between the plates due to specimen deformation. Shear strength is computed from maximum load, and effective shear modulus for the specimen is determined from a plot of load versus slip.

5.2 *This international standard was developed in accordance with internationally recognized principles on standardization established in the Decision on Principles for the Development of International Standards, Guides and Recommendations issued by the World Trade Organization Technical Barriers to Trade (TBT) Committee.*

6. Test Specimen

6.1 Specimen thickness shall be that of the material. Specimens from material that is expected to vary significantly within the specimen due to growth or manufacturing features or from other causes shall be 6 in. (15 cm) wide by 18 in. (45 cm) long or larger

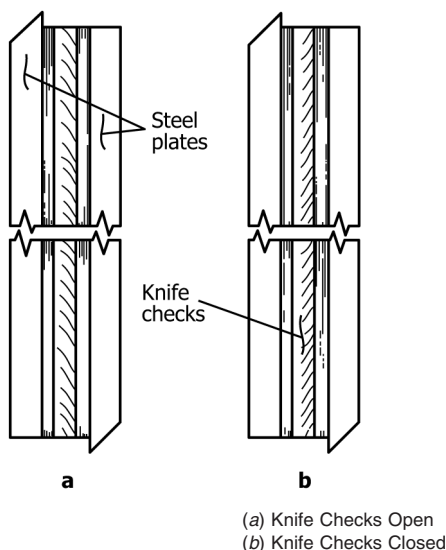

FIG. 1 Orientation of Knife Checks in Plywood

as shown in Fig. 2. This size is recommended for uniform material as well. However, smaller specimens of uniform material may be used if these are not less than four times the thickness in width nor twelve times the thickness in length.

6.2 From each sample of panels containing veneer, two matching specimens shall be cut. Knife edges of loading plates for one specimen of each matching pair shall be oriented perpendicular to one of the primary panel directions or for plywood to cause opening of knife checks during test as shown in Fig. 1(a). Knife edges of plates loading the other specimen shall be positioned perpendicular to one of the primary panel directions or for plywood to cause knife checks to close during test as shown in Fig. 1(b). Proper plywood orientation may be determined from check depth specimens described in 16.3. It may not be possible to test samples having two or more plies stressed in rolling shear in both “open” and “closed” orientations if these plies are oriented in opposite directions causing a “checks open” failure regardless of direction of loading.

6.3 Specimen length and width shall be measured to the nearest 0.01 in. (0.25 mm) and thickness to the nearest 0.001 in. (0.025 mm). When applicable, the direction of knife checks in plies having grain perpendicular to its length shall be determined and the specimens marked for position of knife edges. At the time specimens are cut matching samples for determination of moisture content and specific gravity in accordance with 16.1 and 16.2 shall be obtained. When measurement of knife checks is included as discussed in 16.3, a sample for this measurement also may be cut at this time.

7. Loading

7.1 Figs. 1 and 2 illustrate the specimen and suitable loading plates and blocks for loading the knife edges of the plates. The specimen shall be loaded by steel plates bonded to both faces of the specimen with an adhesive sufficiently rigid to preclude contribution of adhesive creep to measured deformation. Width of plates shall be that of the specimen. One end of each plate shall be provided with a knife edge projecting 1/4 in. (6 mm) beyond the end of the specimen at one end and flush with the surface glued to the specimen. The other end of the plate shall be square and flush with the end of the specimen. Knife edges of the two plates shall be at opposite ends of the specimen and shall be oriented to load the specimen in the desired direction in relation to the knife checks. Planar shear properties of structural panels should be determined in both directions. Plates for specimens 18 in. (45 cm) long shall be 1 in. (2.5 cm) thick. The thickness of plates for shorter specimens may be reduced proportionately. Loading of at least one V-block shall provide for uniform load distribution along the knife edge by loading through a pivot having its axis perpendicular to the knife edge and centered along it. Pivots permitting rotation about an axis parallel to the knife edge or spherical seats free to pivot in this manner shall not be used as they create unstable loading which may cause violent ejection of the specimen from the machine and hazard to operating personnel. The V-blocks shall be vertically positioned in the machine, one above the other, causing the forces applied to the specimen to act parallel to the axis of the machine. The specimen itself will be slightly inclined when placed in the machine. A means of holding the plates in an upright position after the specimen has sheared apart is desirable as a complete separation of the specimen permits the plates to be thrown out of the machine with attendant hazard to the operator.

7.2 Load shall be applied continuously throughout the test at constant rate of cross-head motion to normally produce failure in the range of 3 to 12 min elapsed time from beginning of loading. For plywood, the approximate speed may be determined as follows:

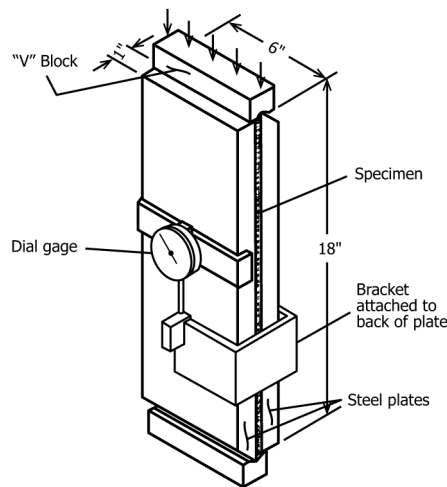

NOTE 1—The “V” block is supported on a seat that provides rotation about the axis perpendicular to the knife edge only.

		Metric Equivalents	
in.		6	18
mm		15	45

FIG. 2 Planar (Rolling) Shear Test Using a Dial Gage for Measuring Plate Slip