



Designation: **F519–17a F519 – 18**

Standard Test Method for Mechanical Hydrogen Embrittlement Evaluation of Plating/ Coating Processes and Service Environments¹

This standard is issued under the fixed designation F519; the number immediately following the designation indicates the year of original adoption or, in the case of revision, the year of last revision. A number in parentheses indicates the year of last reappraisal. A superscript epsilon (ϵ) indicates an editorial change since the last revision or reappraisal.

This standard has been approved for use by agencies of the U.S. Department of Defense.

1. Scope

1.1 This test method describes mechanical test methods and defines acceptance criteria for coating and plating processes that can cause hydrogen embrittlement in steels. Subsequent exposure to chemicals encountered in service environments, such as fluids, cleaning treatments or maintenance chemicals that come in contact with the plated/coated or bare surface of the steel, can also be evaluated.

1.2 This test method is not intended to measure the relative susceptibility of different steels. The relative susceptibility of different materials to hydrogen embrittlement may be determined in accordance with Test Method **F1459** and Test Method **F1624**.

1.3 This test method specifies the use of air melted SAE 4340 steel (Grade A, see **7.1.1**) per SAE AMS 6415 (formerly SAE AMS-S-5000 and formerly MIL-S-5000) or an alternative VAR (Vacuum Arc Remelt) SAE 4340 steel (Grade B, see **7.1.1**) per SAE AMS 6414, and both are heat treated to 260 to 280 ksi (pounds per square inch $\times 1000$) as the baseline. This combination of alloy and heat treat level has been used for many years and a large database has been accumulated in the aerospace industry on its specific response to exposure to a wide variety of maintenance chemicals, or electroplated coatings, or both. Components with ultimate strengths higher than 260 to 280 ksi may not be represented by the baseline. In such cases, the cognizant engineering authority shall determine the need for manufacturing specimens from the specific material and heat treat condition of the component. Deviations from the baseline shall be reported as required by **12.1.2**. The sensitivity to hydrogen embrittlement shall be demonstrated for each lot of specimens as specified in **9.5**.

NOTE 1—Extensive testing has shown that VAR 4340 steel may be used as an alternative to the air melted steel with no loss in sensitivity.²

NOTE 2—VAR 4340 also meets the requirements in AMS 6415 and could be used as an alternative to air melt steel by the steel suppliers because AMS 6415 does not specify a melting practice.

1.4 Test procedures and acceptance requirements are specified for seven specimens of different sizes, geometries, and loading configurations.

1.5 *Pass/Fail Requirements*—For plating/coating processes, specimens must meet or exceed 200 h using a sustained load test (SLT) at the levels shown in **Table 3**.

1.5.1 The loading conditions and pass/fail requirements for service environments are specified in **Annex A5**.

1.5.2 If approved by the cognizant engineering authority, a quantitative, accelerated (≤ 24 h) incremental step-load (ISL) test as defined in **Annex A3** may be used as an alternative to SLT.

1.6 This test method is divided into two parts. The first part gives general information concerning requirements for hydrogen embrittlement testing. The second is composed of annexes that give specific requirements for the various loading and specimen configurations covered by this test method (see section **9.1** for a list of types) and the details for testing service environments.

1.7 The values stated in the foot-pound-second (fps) system in inch-pound units are to be regarded as standard. The values given in parentheses are mathematical conversions to SI units that are provided for information only and are not considered standard.

¹ This test method is under the jurisdiction of ASTM Committee **F07** on Aerospace and Aircraft and is the direct responsibility of Subcommittee **F07.04** on Hydrogen Embrittlement.

Current edition approved Dec. 1, 2017/Nov. 1, 2018. Published December 2017/November 2018. Originally approved in 1977. Last previous edition approved in 2017 as **F519–17:F519 – 17a**. DOI: 10.1520/F0519-17A:10.1520/F0519-18.

² “Final Report - Design of Experiment Approach to Hydrogen Re-Embrittlement Evaluation WP-2152”; S.M Grendahl, H. Nguyen, F. Kellogg, S. Zhu, S. Jones; Strategic Environmental Research and Development Program (SERDP); Project WP-2152; July 2015; <https://www.serd-estcp.org/Program-Areas/Weapons-Systems-and-Platforms/Surface-Engineering-and-StructuralMaterials/WP-2152>.

TABLE 1 Lot Acceptance Criteria for Notched Specimens

Type	Item	Sampling of Each Lot	Requirement/Method
1	Tensile Strength	4 each	Test Method E8. Tensile strength of each specimen must be within 10 ksi of the average.
1	Hardness ^A	5 %	51 to 53 HRC per Test Methods E18. Round the average of three readings per specimen per Practice E29.
1	Dimensions	100 %	Meet tolerances of corresponding drawings. Notch dimension verified with shadow graphic projection at 50 to 100x or equivalent.
1	Notched Fracture Strength (NFS)	10 ea	Test Methods E8/E8M. NFS of each specimen must be within 10 ksi of the average.
1c	Self-loading notched round specimen bend fixture, Fig. A2.7	10 ea	Alternate: The number of turns of the loading bolt, which is required to produce fracture in each specimen, must be within 5 % of the average.
1d	Self-loading notched C-Ring bend fixture, Fig. A2.8	10 ea	Alternate: The change in diameter at fracture load for each specimen must be within 0.008 inches of the average.

^A If the hardness requirements of any of the sampled specimens are not satisfied, only those specimens of the lot that are individually inspected for conformance to these requirements shall be used for testing.

1.8 This standard does not purport to address all of the safety concerns, if any, associated with its use. It is the responsibility of the user of this standard to establish appropriate safety, health, and environmental practices and determine the applicability of regulatory limitations prior to use.

1.9 This international standard was developed in accordance with internationally recognized principles on standardization established in the Decision on Principles for the Development of International Standards, Guides and Recommendations issued by the World Trade Organization Technical Barriers to Trade (TBT) Committee.

2. Referenced Documents

2.1 ASTM Standards:³

- B374 Terminology Relating to Electroplating
- B851 Specification for Automated Controlled Shot Peening of Metallic Articles Prior to Nickel, Autocatalytic Nickel, or Chromium Plating, or as Final Finish
- D1193 Specification for Reagent Water
- E4 Practices for Force Verification of Testing Machines
- E8/E8M Test Methods for Tension Testing of Metallic Materials
- E18 Test Methods for Rockwell Hardness of Metallic Materials
- E29 Practice for Using Significant Digits in Test Data to Determine Conformance with Specifications
- E292 Test Methods for Conducting Time-for-Rupture Notch Tension Tests of Materials
- E691 Practice for Conducting an Interlaboratory Study to Determine the Precision of a Test Method
- E709 Guide for Magnetic Particle Testing
- E1417 Practice for Liquid Penetrant Testing
- E1444 Practice for Magnetic Particle Testing
- E1823 Terminology Relating to Fatigue and Fracture Testing

³ For referenced ASTM standards, visit the ASTM website, www.astm.org, or contact ASTM Customer Service at service@astm.org. For Annual Book of ASTM Standards volume information, refer to the standard's Document Summary page on the ASTM website.

TABLE 2 Electroplating Bath Compositions and Operating Conditions for Sensitivity Test

Item	Treatment A	Treatment B
Bath composition:	Range	Optimum
Cadmium (as CdO)	2.9 to 5.5 oz/gal (22 to 41 g/L)	4.5 oz/gal (33.7 g/L)
Total Sodium cyanide (NaCN)	12.0 to 16.0 oz/gal (89.9 to 120 g/L)	14 oz/gal (104 g/L)
Ratio NaCN to CdO	2.8/1 to 6.0/1	3.0/1
pH	12.0 or greater	12.0
Temperature	70–90°F (21–32°C)	75°F (24°C)
Sodium hydroxide (NaOH) ^A	1.0 to 3.2 oz/gal (7.5 to 24.0 g/L)	2.5 oz/gal (18.7 g/L)
Brightener such as Colcad 100 ^B or equivalent	Manufacturer's suggested range	None
Electroplating current	10 A/ft ² (108 A/m ²)	60 A/ft ² (645 A/m ²)
Electroplating time	30 minutes	6 minutes
Baking		
Baking temperature	375 ± 25°F (190 ± 14°C)	same as Treatment A
Baking time: Type 1 Specimen	Do Not Bake	23 h
Baking time: Type 2a Specimen	8 h	23 h
Chromate Treatment ^C	Yes	same as Treatment A

^A Addition of sodium hydroxide may not be required on solution makeup, since the addition of 1 oz/gal of cadmium oxide is equivalent to 0.6 oz/gal of free hydroxide.
^B The sole source of manufacture of Colcad 100 known to the committee at this time is Columbia Chemical in Brunswick, Ohio, www.columbiachemical.com. If you are aware of alternative manufacturers, please provide this information to ASTM International Headquarters. Your comments will receive careful consideration at a meeting of the responsible technical committee, which you may attend.
^C After baking, the specimens shall be dipped into any appropriate chromate conversion coating solution for minimum time that will produce an adherent and continuous coating as described in AMS-QQ-P-416 Type II.

TABLE 3 Pass/Fail Loading Requirements of Test Specimens

Type 1a, 1b, 1c, 1d, 1e	75 % of the tensile or bend NFS (Table 1).
Type 2a	92 % of the Test Methods E8/E8M, E4 ultimate strength, obtained by deflecting a 2.300-inch diameter O-Ring specimen with a 2.525-inch stressing bar.

- [F1459 Test Method for Determination of the Susceptibility of Metallic Materials to Hydrogen Gas Embrittlement \(HGE\)](#)
[F1624 Test Method for Measurement of Hydrogen Embrittlement Threshold in Steel by the Incremental Step Loading Technique](#)
[F2078 Terminology Relating to Hydrogen Embrittlement Testing](#)
[G5 Reference Test Method for Making Potentiodynamic Anodic Polarization Measurements](#)
[G38 Practice for Making and Using C-Ring Stress-Corrosion Test Specimens](#)
 2.2 *SAE AMS Standard:*⁴
[AMS 2430 \(R\) Shot Peening, Automatic](#)
[AMS 2759/2 Heat Treatment of Low-Alloy Steel Parts Minimum Tensile Strength 220 ksi \(1517 MPa\) and Higher](#)
[AMS 2759/11 Stress Relief of Steel Parts](#)
[AMS 6360 Steel Tubing, Seamless 0.95Cr – 0.20Mo \(0.28 – 0.33C\) \(SAE 4130\) Normalized or Stress Relieved](#)
[AMS 6414 Steel, Bars, Forgings, and Tubing \(SAE 4340\) Vacuum Consumable Electrode Remelted](#)
[AMS 6415 Steel, Bars, Forgings, and Tubing \(SAE 4340\)](#)
[AMS-QQ-P-416 Plating, Cadmium \(Electrodeposited\)](#)
 2.3 *Military and Federal Standards and Commercial Item Descriptions:*⁵
[MIL-PRF-16173 Corrosion Preventive Compound, Solvent Cutback, Cold-Application](#)
[Commercial Item Description \(CID\) A-A-55827 Chromium Trioxide, Technical](#)

3. Terminology

3.1 *Definitions*—Definitions of terms used in this test method may be found in Terminology [B374](#), Terminology [E1823](#) and Terminology [F2078](#).

3.2 *Acronyms and Abbreviations:*

AIISI = American Iron and Steel Institute
a/W = notch depth-to-width ratio

⁴ Available from Society of Automotive Engineers (SAE), 400 Commonwealth Dr., Warrendale, PA 15096-0001, <http://www.sae.org>.

⁵ Copies of these documents are available at <http://assist.daps.dla.mil/quicksearch/> or <http://assist.daps.dla.mil> or from the Standardization Document Order Desk, 700 Robins Ave., Building 4D, Philadelphia, PA 19111-5094.

d/D = ratio of minor to major diameters at the notch
ESH = Environmental, Safety and Health
fps = foot pound second
HRC = Rockwell Hardness Scale C
ID = inside diameter
ISL = incremental step load
kip = pounds load multiplied by 1000
ksi = pounds-force per square inch multiplied by 1000
K_t = stress concentration factor
LS = longitudinal short transverse
NFS = notched fracture strength
OD = outside diameter
psi = pounds-force per square inch
RMS = root mean square
SAE AMS = Society of Automotive Engineers Aerospace Material Specification
SCE = saturated calomel electrode
SLT = sustained load test
T.I.R. = total indicated runout

4. Summary of Test Methods

4.1 *Plating/coating Processes*—Unstressed test specimens are cleaned, plated/coated, and baked (if applicable) in accordance with the specification to which the process is to be qualified. Specimens are then maintained under a sustained load in air to measure the time to rupture/completion of the test period.

4.2 *Service Environments*—Specimens are tested in the service environment. The sequence of exposure to the environment and loading shall be as defined in [Annex A5](#). If plated/coated test specimens are to be utilized for evaluating a service environment, then the plating/coating process must first be determined to be acceptable in accordance with [4.1](#).

5. Significance and Use

5.1 *Plating/coating Processes*—This test method provides a means by which to detect possible hydrogen embrittlement of steel parts during manufacture by verifying strict controls during production operations such as surface preparation, pretreatments, and plating/coating. It is also intended to be used as a qualification test for new plating/coating processes and as a periodic inspection audit for the control of a plating/coating process.

5.2 *Service Environment*—This test method provides a means by which to detect possible hydrogen embrittlement of steel parts (plated/coated or bare) due to contact with chemicals during manufacturing, overhaul and service life. The details of testing in a service environment are found in [Annex A5](#).

6. Apparatus

6.1 *Testing Machine*—Testing machines shall be within the guidelines of calibration, force range, resolution, bending strain, and verification of Practices [E4](#) and Test Methods [E292](#) as applicable.

6.1.1 The force measurement on test machines used for notched round tension specimens, shall be via analytical calculations such as for dead weight or lever arm type hanging weight machines, or by routine empirical measurement (electronic output) such as for strain gauge load cells. Estimating test loads that are derived from load ring deflections only is not allowed, unless the effects of specimen grip joint compliance is known, is accounted for, and within Practice [E4](#) and Test Method [E8/E8M](#) tolerances. Strain gauge load cell measurements/results can be used in conjunction with load ring deflections.

6.2 *Gripping Devices*—Various types of gripping devices may be used in either tension or bending to transmit the load applied by the testing machine or self-loading frame to the test specimen.

6.3 *Series Loading*—Samples may be loaded on a test frame either individually or by multiples in series. All specimens loaded onto an individual test frame shall have the same certified NFS $\pm 1\%$. In the event that one or more of the specimens fracture during the designated test period, the fractured specimen(s) shall be removed, replaced with a dummy specimen and the load chain placed back under load. The total time under load (that is, test duration) for the remaining specimens shall be extended by any time-off-load as detailed in [6.3.1](#). The procuring specification or cognizant engineering authority may elect to restrict loading to one specimen per test frame.

6.3.1 *Extended Time Under Load (ETUL)*—If the total time-off-load (wall clock) exceeds 10 % of the total test duration (for example, 20-h for a 200-h test); then the time under load shall be extended by the amount of time-off-load in excess of 10 % (that is, in excess of 20 h). The procuring specification or cognizant engineering authority may elect to waive this extended time under load (ETUL) protocol.

EXAMPLE 1 for SLT

Four cadmium-plated specimens representing a single plating bath are loaded on an individual SLT test frame as part of a monthly plating bath verification. One of the four specimens fractures after 180 h (initial time under load = 180 h). It takes 8 h to discover the fractured specimen, replace it with a dummy link, and put the remaining three specimens back under load (time off-load = 8 h). No extension of time under load is required since the time off-load (8 h) was less than 10 % of the total test duration (10 % of 200 h = 20 h). Total time under load will therefore be 200 h for the remaining specimens.

EXAMPLE 2 for SLT

Twenty cadmium-plated specimens representing five distinct plating baths (A, B, C, D, and E) are loaded on an individual SLT test frame as part of a monthly plating bath verification. One specimen from bath A fractures after 100 h; one specimen from bath B fractures after 120 h; and one specimen from bath C fractures after 140 h. Each time a specimen fractures, it takes 8 h to discover the fractured specimen, replace it with a dummy link, and put the remaining specimens back under load (total time off-load = 8+8+8 h = 24 h). The total time off-load (24 h) exceeds 10 % of the total test duration (10 % of 200 = 20 h) by 4 h. Therefore, the time under load must be extended by 4 h. Total time under load will therefore be 204 h for the remaining specimens.

6.4 Service Environment Testing—For testing in service environments, an inert container and fixture arrangement that is suitably electrically isolated from the specimen or compensated to prevent galvanic coupling shall be used for testing in aqueous environments. The corrosion potential of the specimen may be controlled with a reference Saturated Calomel Electrode (SCE) or equivalent reference electrode such as with Ag/AgCl in accordance with Reference Test Method **G5**.

7. Materials and Reagents

7.1 Materials:

7.1.1 Steel shall be:

7.1.1.1 Grade A - Air melted SAE 4340 steel per SAE AMS 6415 (formerly SAE AMS-S-5000 and formerly MIL-S-5000) or

7.1.1.2 Grade B - VAR (Vacuum Arc Remelt) SAE 4340 steel per SAE AMS 6414.

7.1.1.3 If no Grade is specified, Grade A shall be used.

7.1.2 Aluminum oxide (150 grit or finer), and 180-grit silicon-carbide paper.

7.1.3 Conditioned shot, in accordance with AMS 2430.

7.2 Reagents:

7.2.1 Corrosion preventive compound, meeting the requirements of MIL-PRF-16173, Grade 2.

7.2.2 Cadmium cyanide electroplating bath (SAE AMS-QQ-P-416, formerly Federal Specification QQ-P-416. (**Table 2**).

7.2.3 Maintenance chemicals, cleaners, paint strippers, and aqueous environments.

7.2.4 Chromic acid (CID A-A-55827, formerly Federal Specification O-C-303D).

7.2.5 Water (Specification **D1193** Type IV).

8. Hazards

8.1 Environmental, Safety and Health (ESH):

8.1.1 Equipment, materials, solutions, and emissions (if applicable) shall be controlled, handled, used, and disposed in accordance with the applicable governing ESH regulations.

9. Test Specimens

9.1 Configuration:

9.1.1 Dimensional drawings with tolerances are given for the two types of specimens in the following annexes:

9.1.1.1 Type 1—Notched Specimens

Type 1a: Notched, Round, Tension

Type 1a.1—Standard Size—per **Fig. A1.1**

Annex A1

Type 1a.2—Oversized—per **Fig. A1.2**

Annex A1

Type 1b: Notched, Round, Tension Self Loading Fixture—
per

Annex A2

Figs. A2.1-A2.5

Type 1c: Notched, Round, Bend Self Loading Fixture—per

Annex A2

Fig. A2.6, Fig. A2.7

Type 1d: Notched, C-Ring, Bend Self Loading Fixture—per

Annex A2

Fig. A2.8, Fig. A2.9

Type 1e: Notched, Square, Bend—per **Fig. A3.1**

Annex A3

9.1.1.2 Type 2—Smooth Specimens

Type 2a: O-Ring, Bend Self Loading Fixture—per **Fig. A4.1,**

Annex

Fig. A4.2

A4

9.1.2 The notched round tension, round bend and square bend specimens shall be loaded in the longitudinal grain direction, but the C-Ring and O-Ring can only be loaded normal to the longitudinal grain direction.

9.2 Manufacture:

9.2.1 Stress concentration factors (K_t) for each of the specimen types were calculated using Finite Element Analysis (FEA) and the dimensions in the drawings.

NOTE 3—An ASTM Research Report documenting the analysis is in process and a reference number will be included in a future revision.

Type	K _t		
	Minimum ^A	Nominal	Maximum ^A
1a.1	3.16	3.30	3.48
1a.2	3.31	3.59	3.76
1b	2.86	3.07	3.33
1c	3.30	3.45	3.62
1d	3.73	4.03	4.42
1e	3.95	4.27	4.60
2a	NA	NA	NA

^A Minimum and maximum K_ts calculated from worst case combinations of dimensional tolerances.

9.2.2 If the 60° notch angle does not permit plating/coating to the root of the notch, then an angle of 90° ± 1° shall be used only with prior approval of the cognizant engineering authority.

NOTE 4—The FEA determined that changing the notch angle from 60° to 90° had a negligible affect on the K_t. Therefore, no dimensional changes are required to compensate for this deviation. However, such deviation shall be reported as required in 12.1.2.

9.2.3 The baseline material/condition for test specimens is normalized and tempered, hot or cold drawn bar stock, air melted SAE 4340 steel per AMS 6415 (Grade A, see 7.1.1.1) or VAR SAE 4340 steel per AMS 6414 (Grade B, see 7.1.1.2), heat treated per AMS 2759/2 Class A to a tensile strength between 260 and 280 ksi (51 to 53 Rockwell C Hardness Scale (HRC)) as determined according to Test Methods E18. Rounding per Practice E29 permits an absolute hardness range of 50.6 to 53.4 HRC of the average of three measurements.

9.2.3.1 Other steels or final hardnesses may only be substituted if agreed upon by the cognizant engineering authority. Deviations from the baseline shall be reported as required in 12.1.2.

9.2.4 Rough machine blanks as required.

9.2.5 Heat treat as a finished part to a strength level of 260 to 280 ksi per AMS 2759/2 Class A or B as follows:

9.2.5.1 Austenitize at 1500 – 1550°F in a protective atmosphere and then quench in oil.

9.2.5.2 Double temper, 2 h each, at 425 – 490°F.

9.2.6 Verify heat treat response by pulling 4 specimens in accordance with Test Method E8/E8M and Table 1.

9.2.7 Finish machine the reduced section and notch configuration.

9.2.7.1 The entire notch shall be ground to size.

9.2.7.2 Single-point machining of the notch is not permitted.

9.2.7.3 Burnishing of the notch is not permitted.

9.2.7.4 Shot peening/blasting/mechanical cleaning of the notch during specimen manufacturing is not permitted.

9.2.8 After grinding, all specimens shall receive a stress relief bake at 375 ± 25°F (190 ± 14°C) per AMS 2759/11 for 4–5 h. A suitable protection from discoloration due to surface oxidation shall be used during the stress relief bake.

9.2.9 Acid or cathodic electrolytic cleaning is prohibited.

9.2.10 Straightening after final heat treatment is prohibited.

9.3 Storage:

9.3.1 After stress relief baking, all specimens shall be protected during storage to prevent corrosion. A suitable means of protection is to coat the specimen with a corrosion preventive compound meeting the requirements of MIL-PRF-16173, Grade 2.

9.4 Inspection:

9.4.1 A lot shall consist of those specimens cut from the same heat of steel in the same orientation, heat treated together in the same furnace load, quenched and tempered together and subjected to the same manufacturing processes together.

9.4.2 All notched specimens in the lot shall be suitable for test purposes if the inspection results on samples from that lot conform to the requirements of Table 1 and 9.5.

9.5 Sensitivity Test:

9.5.1 The sensitivity to hydrogen embrittlement shall be demonstrated for each lot of specimens by exposing six trial specimens to two different embrittling environments after manufacture and inspection in accordance with Section 9.

9.5.1.1 Three specimens shall be electroplated under the highly embrittling conditions produced in a bright cadmium cyanide bath by Treatment A (Table 2) and the remaining three specimens shall be electroplated under the less embrittling conditions of Treatment B (Table 2). An equivalent plating/coating or imposed potential may be used only with the approval of the cognizant engineering authority if its sensitivity is demonstrated to be equivalent to that found in Table 2.

9.5.2 Using the SLT method, each lot of specimen shall be of suitable sensitivity only if all three specimens plated by Treatment A fracture within 24 h and none of the three specimens plated by Treatment B fracture within 200 h after applying the sustained loads specified in Table 3.

9.5.3 Using the ISL test method, each lot of specimens shall be of suitable sensitivity only if all three specimens plated by Treatment A initiate a crack at less than 50 % NFS and all of the three specimens plated by Treatment B fracture above 90% NFS identified in Table 3. The loading profile to be used with this standard is fifteen load increments of 5 % NFS sustained for one hour plus five increments of 5 % NFS for 2 h each or (15/5/1) + (5/5/2), which totals to a maximum of 24 hour loading profile for a maximum anticipated load of 100 % NFS.

9.6 Certification:

9.6.1 Each lot of specimens manufactured and sold shall be certified in writing to indicate that it meets the conditions found in this section, including the following information:

9.6.1.1 Manufacturer of specimen lot.

9.6.1.2 Steel supplier, heat number, and certificate for chemical composition and heat treatment response.

9.6.1.3 Heat treat process certification for specimen lot.

9.6.1.4 Test results for requirements in **Table 1** and **9.6**, including the corresponding average rupture load in units of X.XX kips (1 kip = 1000 pounds load).

10. Procedure

10.1 Plating/coating Processes:

10.1.1 *Number of Specimens*—A minimum of four specimens shall be used per test.

10.1.2 *Re-Use of Specimens*—Test specimens produced and tested per this test method shall only be used once. Stripping and reuse of specimens are prohibited.

10.1.3 *Plating/Coating Coverage*—The entire specimen with the exception of the grip areas shall be covered by plating/coating as determined by a visual inspection.

10.1.4 *Masking of Grip Areas of Specimens*—The grip areas of the specimens may be masked to prevent plating/coating deposit when required to avoid interference with the test fixture. If the grip area is masked, this fact shall be reported.

10.1.5 *Masking To Provide Hydrogen Escape Path*—Non-porous plating/coatings such as nickel or bright cadmium can inhibit the outward diffusion of hydrogen. Therefore, when plating specimens with these types of plating/coatings it is necessary to leave a portion of the specimen unplated/coated so that the hydrogen can be baked out. The following guidelines are established for masking specimens to be plated/coated with hard, non-porous coatings:

10.1.5.1 *All notched Types (1a.1, 1a.2, 1b, 1c, 1d, and 1e)*—The entire notch and 0.5 inch on either side of the notch shall be plated/coated.

10.1.5.2 *Type 2a Smooth Ring*—Only the edges may be masked. The entire ID and OD shall be plated/coated.

10.1.6 *Dimensions for Stress Calculations*—The dimensions of the bare metal specimen shall be used in stress calculations.

10.1.7 SLT Method:

10.1.7.1 *Load*—Sustained load specimens shall be loaded in accordance with **Table 3**.

10.1.7.2 *Time*—Sustained loads shall be maintained for a minimum of 200 h. Actual fracture times may be electronically monitored with a relay switch system.

10.1.8 The alternate, ISL accelerated test (≤ 24 h) as described in **Annex A3** of this document and as further defined in Test Method **F1624** may be used only if specified by the cognizant engineering authority.

10.2 Service Environments:

10.2.1 The testing protocol (number, load, and time) shall be as specified in **Annex A5**.

11. Interpretation of Results

11.1 *No Fracture*—For the SLT method, a plating/coating process shall be considered non-embrittling if none of the plated/coated specimens fracture within 200 h after loading as specified in **Table 3**. Self-loading specimen Types (1b, 1c, 1d and 2a) may need to be examined using magnetic particle per Practice **E1444** or liquid penetrant per Practice **E1417** to determine if a crack initiated but did not propagate due to load relaxation.

11.2 *One of Four Fracture*—If only one of a minimum of four specimens fractures within the 200-h sustained load exposure time, the remaining three specimens may be step loaded every 2 h in 5 % increments to 90 % of the NFS after completion of the 200-h sustained load. If the three remaining specimens all sustain 90 % NFS for 2 h, the plating/coating process shall be considered non-embrittling.

11.3 *Two or More Fracture*—If two or more specimens fracture within the sustained load exposure time, the plating/coating process shall be considered embrittling.

11.4 *Replacement Testing*—Replacement testing shall only be conducted after the root cause of any failure has been determined to be anomalous.

11.4.1 *Root Cause Determination*—A failure may be ruled anomalous if it is determined that an error was made in the plating/coating process of the specimens or if a metallurgical examination of the fractured specimen indicates some defect in the manufacture of the specimen.

11.4.1.1 Pre-existing specimen defects such as cracks, grinding burns, or nonmetallic inclusions can be considered a basis for invalidation of test results and replacement testing.

11.4.1.2 Fracture at any location other than the notch invalidates the test and is a basis for replacement testing for all notched specimens (that is, all types except 2a).

11.4.2 *Number of Specimens*—A replacement test shall use four specimens. If any specimen fractures during the replacement test, the plating/coating process shall be considered embrittling. If the failure is determined to be anomalous, retesting per 11.4 may be repeated.

12. Report

12.1 A test record or report shall be produced upon completion of testing that bears the minimum information specified in 12.1.1 through ~~12.1.7~~12.1.8. The testing laboratory shall provide the information required in 12.1.4 through 12.1.8 in a test record or report to the customer that provided the specimens for testing.

12.1.1 A lot acceptance and sensitivity certification record or report in accordance with the requirements of Table 1 and 9.5 that clearly identifies the notched fracture strength (NFS) for the specimen lot(s) being tested.

NOTE 5—The lot acceptance and sensitivity record or report may be provided by the specimen manufacturer.

12.1.2 ~~The type and number of specimens tested including deviations~~ Deviations from baseline geometry, material, temper, K_t , or masking practices. If samples conform to requirements, the report shall so state.

12.1.3 A description of the plating/coating process used on the test specimens.

12.1.4 ~~A description of the plating/coating process and test environment (concentration, temperature, and so forth) if other than ambient air.~~

12.1.5 The sustained or threshold load applied, or percent of NFS or notch bend strength of unplated specimens, or displacement as appropriate for the type of specimen tested.

12.1.6 The Type and number of specimens on the test frame together; their certified NFSs; details of any specimen fractures along with associated time-off-load; and any Extended Time Under Load (ETUL).

12.1.7 ~~The time under load in the test environments~~ environments, and if fractures were observed, they shall be reported. If the test conforms to requirements, the report shall so state.

12.1.8 ~~If fractures were observed, they shall be reported. If samples conform to requirements, the report shall so state. If step-loading protocol of 11.2 is invoked, it shall state why with reference to fractures, and it shall be clearly noted on the face of the certification in the test record or report.~~

13. Precision and Bias

13.1 *Precision*—The sensitivity test requirement in 9.5 and the acceptance and rejection criteria in Section 11 are the judgments for precision, and may vary with the precision on applied stress and test specimen geometry.

13.2 *Bias*—Random lot-to-lot bias in the properties of specimens related to raw material or specimen manufacture may exist.

14. Keywords

14.1 cleaner; coating; delayed failure; fluids; hydrogen embrittlement; maintenance chemicals; plating/coating; steel; stress cracking; threshold

ANNEXES

(Mandatory Information)

A1. SPECIAL REQUIREMENTS FOR THE TESTING OF NOTCHED ROUND TENSION SPECIMENS

A1.1 *Type 1a*—The notched round tension specimen is given in two sizes. If the specimen geometry is not called out, the Type 1a.1, standard notched round specimen under load control, shall be used.

A1.1.1 *Type 1a.1 Standard*—The dimensions for the standard sized specimen for the sustained load test (SLT) are shown in Fig. A1.1. The test machine shall have a minimum load capacity of 10 kips to measure the NFS in accordance with Table 1. Correspondingly, a test machine with a minimum load capacity of 7.5 kips is required to maintain a sustained load of 75 % of the NFS in accordance with Table 3.

A1.1.2 *Type 1a.2*—The dimensions for the oversized specimen for SLT are shown in Fig. A1.2. The test machine must have a minimum capacity of 16 kips to measure the NFS in accordance with Table 1. Correspondingly, a minimum 12-kip test machine is required to maintain a sustained load of 75 % of the NFS in accordance with Table 3.

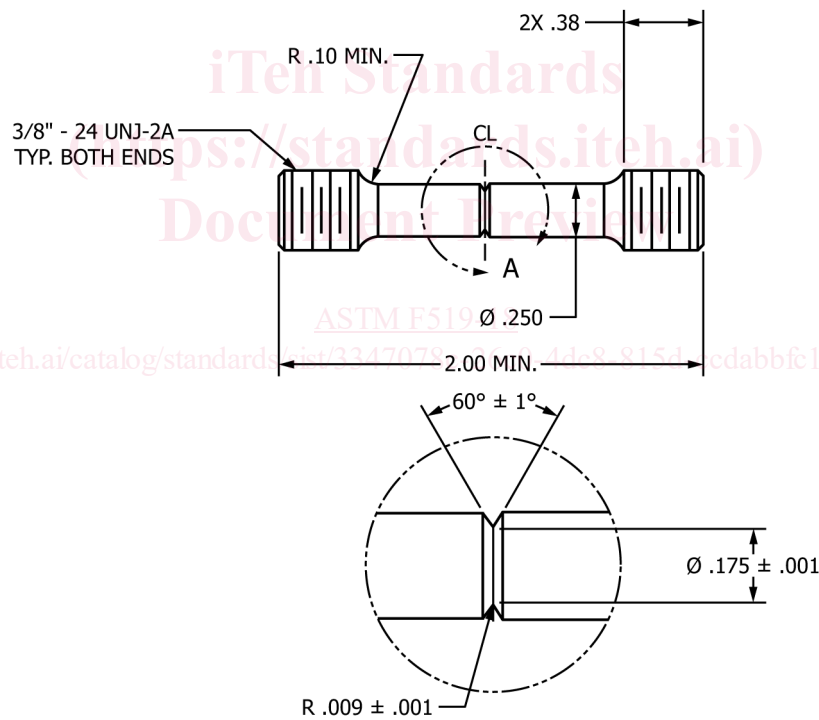

DETAIL A

Tolerances unless otherwise specified:
 X.X ± 0.1
 X.XX ± 0.03
 X.XXX ± 0.005

NOTE 1—Specimen preparation must comply with 9.2.

NOTE 2—Surface finish of notch shall be 32 RMS or better, all other surfaces shall be 63 RMS or better.

NOTE 3—Configuration of the ends of the specimen is optional so long as any external threaded ends have the minor diameter greater than 0.25 inch.

NOTE 4—Root radii, reduced section, and notch root radius must be concentric with centerline of specimen within 0.002 T.I.R. (total indicated runout).

FIG. A1.1 Dimensional Requirements for the Type 1a.1 Specimen

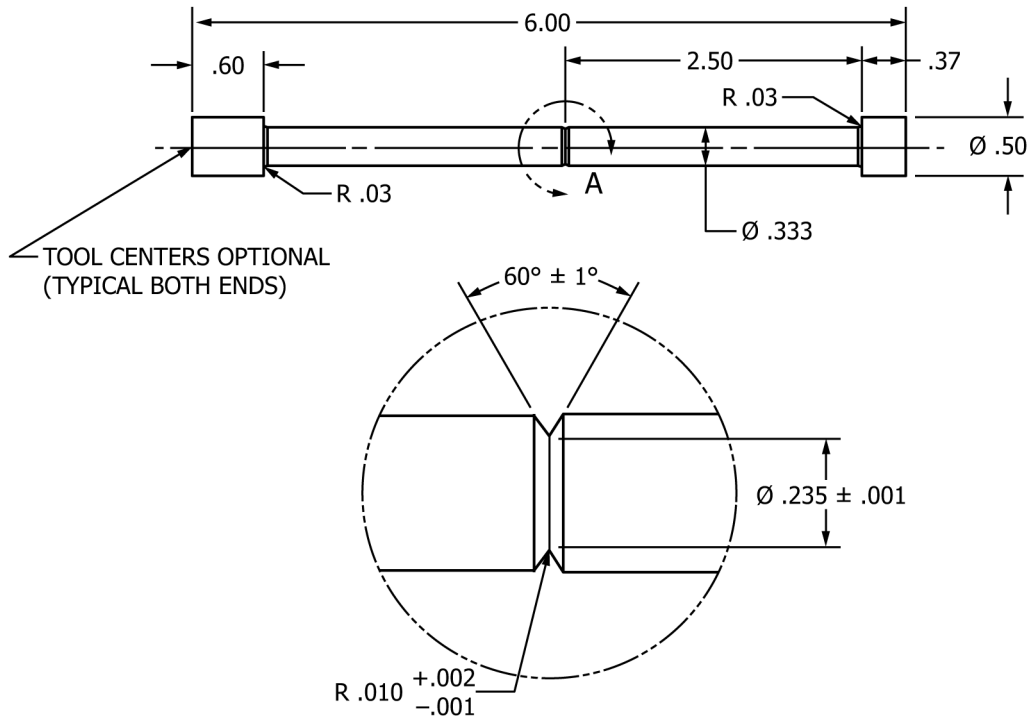

DETAIL A
 Tolerances unless otherwise specified:
 X.X \pm 0.1
 X.XX \pm 0.05
 X.XXX \pm 0.007

- NOTE 1—Specimen preparation must comply with 9.2.
 NOTE 2—Surface finish of notch shall be 32 RMS or better, all other surfaces shall be 63 RMS or better.
 NOTE 3—Configuration of the ends of the specimen is optional so long as any external threaded ends have the minor diameter greater than 0.35 inch.
 NOTE 4—Root radii, reduced section, and notch root radius must be concentric with centerline of specimen within 0.002 T.I.R.

FIG. A1.2 Dimensional Requirements for the Type 1a.2 Specimen

<https://standards.iteh.ai/catalog/standards/sist/3347078c-26c0-4dc8-815d-ccdabbfc126c/astm-f519-18>

A2. SPECIAL REQUIREMENTS FOR THE TESTING OF NOTCHED SPECIMENS IN SELF-LOADING FIXTURE

A2.1 *Type 1b—Notched Tension Specimen*—Type 1b is a sub-sized specimen where the ratio of minor to major diameters at the notch (d/D) = 0.0895/0.188). The specimen is loaded under a constant displacement and requires a special sustained loading device for loading to 75 % of the NFS. The capacity of the testing machine for determination of the NFS in accordance with Table 1 must exceed 2.5 kips. Consideration should also be given to Test Methods E8/E8M – 04, Note 5, Figure 8 concerning the use of subsize specimens.

A2.1.1 The method of spring-loading notched round specimens in tension uses a pre-calibrated ring as detailed in Figs. A2.1-A2.5. The ring manufacturer calibrates each ring by determining the change in diameter of the ring when subjected to a load equivalent to that required to stress a test specimen to 75 % NFS.

A2.1.2 Mechanisms used to load a test specimen in a stressed ring must be able to hold the test specimen at a stress level of 90 % of the maximum load applied to the specimen. A method that allows loading and locking test specimens at stress levels as high as 75 % NFS is described as follows.

A2.1.3 Insert the test specimen in a calibrated ring. Fit the end of the specimen extending through the ring with a stainless steel retaining collar and insert it into the jaws of a hydraulic loading device. As the load is applied, the collar is swaged to the shaft