



Designation: **E966 – 18** E966 – 18a

Standard Guide for Field Measurements of Airborne Sound Attenuation of Building Facades and Facade Elements¹

This standard is issued under the fixed designation E966; the number immediately following the designation indicates the year of original adoption or, in the case of revision, the year of last revision. A number in parentheses indicates the year of last reapproval. A superscript epsilon (ϵ) indicates an editorial change since the last revision or reapproval.

INTRODUCTION

This guide provides methods to measure the sound isolation of a room from outdoor sound, and to evaluate the sound transmission or apparent sound transmission through a particular facade of the room or an element of that facade such as a window or door. Measurements from outdoors to indoors differ from measurements between two rooms. The outdoor sound field is not diffuse and the transmission of that sound through the structure is a function of the outdoor sound angle of incidence. The outdoor-indoor transmission loss values obtained with this guide are not expected to be the same as that obtained in laboratory or other tests between two rooms using diffuse incident sound. At this time, there are insufficient data available to specify a single, standard measurement procedure suitable for all field situations. For this reason, this guide provides alternative test procedures for the measurements of facade field level reduction and transmission loss.

This guide is part of a set of standards for evaluating the sound isolation of rooms and the sound insulating properties of building elements. Others in this set cover the airborne sound transmission loss of an isolated partition element in a controlled laboratory environment (Test Method E90), the laboratory measurement of impact sound transmission through floors (Test Method E492), the measurement of airborne sound transmission in buildings (Test Method E336), the measurement of impact sound transmission in buildings (Test Method E1007), the field measurement of airborne sound insertion loss of doors (Test Method E2964), and the laboratory measurement of sound transmission through a common plenum between two rooms (Test Method E1414).

1. Scope

1.1 This guide may be used to determine the outdoor-indoor noise reduction (OINR), which is the difference in sound pressure level between the free-field level outdoors in the absence of the structure and the resulting sound pressure level in a room. Either a loudspeaker or existing traffic noise or aircraft noise can be used as the source. The outdoor sound field geometry must be described and calculations must account for the way the outdoor level is measured. These results are used with Classification E1332 to calculate the single number rating outdoor-indoor noise isolation class, OINIC. Both OINR and OINIC can vary with outdoor sound incidence angle.

1.2 Under controlled circumstances where a single facade is exposed to the outdoor sound, or a facade element such as a door or window has much lower transmission loss than the rest of the facade, an outdoor-indoor transmission loss, OITL(θ), or apparent outdoor-indoor transmission loss, AOITL(θ), may be measured using a loudspeaker source. These results are a function of the angle of incidence of the sound field. By measuring with sound incident at many angles, an approximation to the diffuse field transmission loss as measured between two rooms can be obtained. The results may be used to predict interior sound levels in installations similar to that tested when exposed to an outdoor sound field similar to that used during the measurement. The single number ratings of apparent outdoor-indoor transmission class, AOITC(θ), using AOITL(θ) and field outdoor-indoor transmission class, FOITC(θ), using OITL(θ) may be calculated using Classification E1332. These ratings also may be calculated with the data obtained from receiving room sound pressure measurements performed at several incidence angles as discussed in 8.6.

¹ This guide is under the jurisdiction of ASTM Committee E33 on Building and Environmental Acoustics and is the direct responsibility of Subcommittee E33.03 on Sound Transmission.

Current edition approved Jan. 15, 2018/Nov. 1, 2018. Published January 2018/November 2018. Originally approved in 1984. Last previous edition approved in 2010/2018 as E966 – 10/E966 – 18. DOI: 10.1520/E0966-18.10.1520/E0966-18A.

1.3 To cope with the variety of outdoor incident sound field geometries that are encountered in the field, six testing techniques are presented. These techniques and their general applicability are summarized in **Table 1** and **Figs. 1-6**. The room, façade, or façade element declared to be under test is referred to as the specimen.

1.4 The text of this standard references notes and footnotes which provide explanatory material. These notes and footnotes (excluding those in tables and figures) shall not be considered as requirements of the standard.

1.5 The values stated in SI units are to be regarded as standard. No other units of measurement are included in this standard.

1.6 *This standard does not purport to address all of the safety concerns, if any, associated with its use. It is the responsibility of the user of this standard to establish appropriate safety, health, and environmental practices and determine the applicability of regulatory limitations prior to use.*

1.7 *This international standard was developed in accordance with internationally recognized principles on standardization established in the Decision on Principles for the Development of International Standards, Guides and Recommendations issued by the World Trade Organization Technical Barriers to Trade (TBT) Committee.*

2. Referenced Documents

2.1 ASTM Standards:²

C634 Terminology Relating to Building and Environmental Acoustics

E90 Test Method for Laboratory Measurement of Airborne Sound Transmission Loss of Building Partitions and Elements

E336 Test Method for Measurement of Airborne Sound Attenuation between Rooms in Buildings

E492 Test Method for Laboratory Measurement of Impact Sound Transmission Through Floor-Ceiling Assemblies Using the Tapping Machine

E1007 Test Method for Field Measurement of Tapping Machine Impact Sound Transmission Through Floor-Ceiling Assemblies and Associated Support Structures

E1332 Classification for Rating Outdoor-Indoor Sound Attenuation

E1414 Test Method for Airborne Sound Attenuation Between Rooms Sharing a Common Ceiling Plenum

E2235 Test Method for Determination of Decay Rates for Use in Sound Insulation Test Methods

E2964 Test Method for Measurement of the Normalized Insertion Loss of Doors

2.2 ANSI Standards:³

S1.11 Specification for Octave-Band and Fractional-Octave Analog and Digital Filter Sets

S1.40 Specifications and Verification Procedures for Sound Calibrators

S1.43 Specifications for Integrating -Averaging Sound Level Meters

2.3 IEC Standards:³

IEC 61672 Electroacoustics - Sound Level Meters

IEC 60942 Electroacoustics - Sound Calibrators

ASTM E966-18a

<https://standards.iteh.ai/catalog/standards/sist/f5d1fa4-fea0-48de-83e1-f4e756e6c0b3/astm-e966-18a>

3. Terminology

3.1 *Definitions*—for acoustical terms used in this guide, see Terminology **C634**.

3.2 *Definitions of Terms Specific to This Standard:*

TABLE 1 Application Guide to Measurement of Outdoor-Indoor Level Reduction ONIR

Outdoor Signal Source Loudspeaker Required for OITL or AOTL	Outdoor Microphone Position	Measurement Section, Figure, Calculation Equation	Applications Remarks
Calibrated loudspeaker	Incident sound pressure inferred from separate calibration of source	8.3.1, Fig. 1; Eq 3	Use when outdoor measurement at or near specimen is not possible.
Loudspeaker	Several locations averaged about 1.2 m to 2.4 m from the facade element	8.3.2, Fig. 2; Eq 4	Use when calibrated source or flush measurement is not possible.
Loudspeaker	Several locations less than 17 mm from specimen	8.3.3, Fig. 3; Eq 5	Use when the loudspeaker cannot be calibrated.
Traffic, aircraft, or similar line source	Simultaneous measurement remote from the specimen	9.3.1, Fig. 4; Eq 7	Use when it is possible to measure source in free field at same distance as specimen.
Traffic, aircraft, or similar line source	Simultaneous measurement 2 m from the specimen surface	9.3.2, Fig. 5; Eq 9	Use when remote measurement or flush measurement is not possible.
Traffic, aircraft, or similar line source	Simultaneous measurement with entire microphone diaphragm within 17mm of the specimen	9.3.3, Fig. 6; Eq 10	Use when remote measurement is not possible.

² For referenced ASTM standards, visit the ASTM website, www.astm.org, or contact ASTM Customer Service at service@astm.org. For *Annual Book of ASTM Standards* volume information, refer to the standard's Document Summary page on the ASTM website.

³ Available from American National Standards Institute (ANSI), 25 W. 43rd St., 4th Floor, New York, NY 10036, <http://www.ansi.org>.

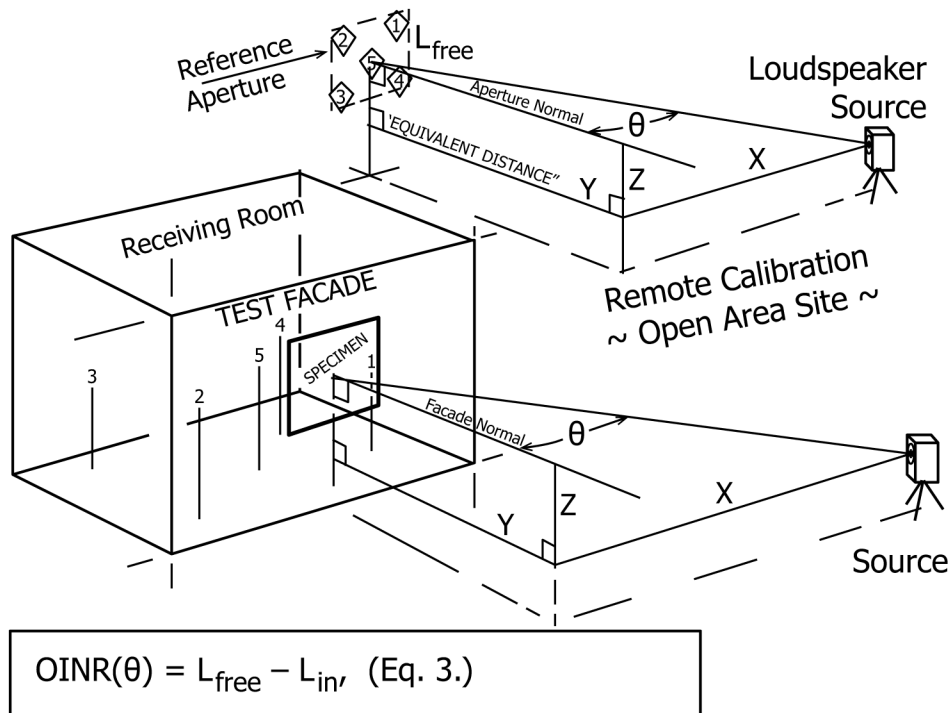

FIG. 1 Geometry—Calibrated Source Method

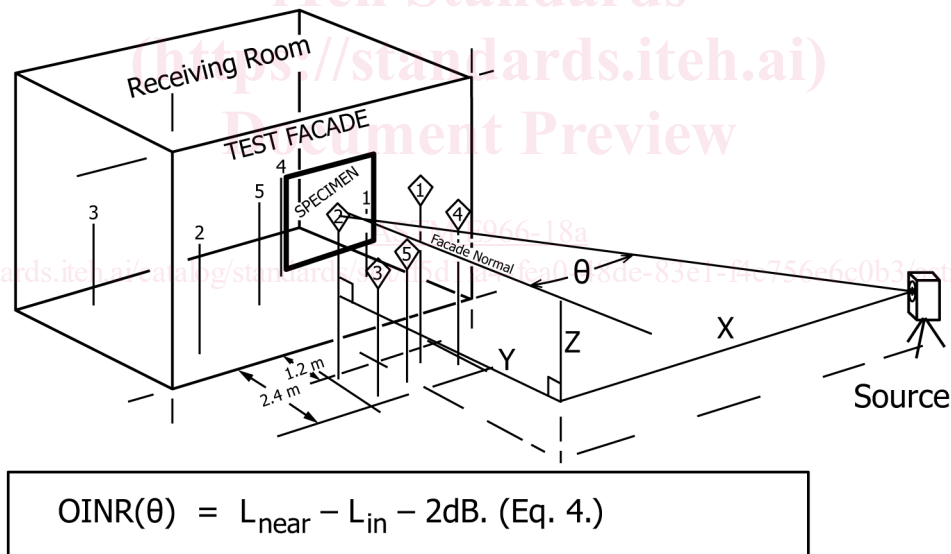

FIG. 2 Geometry—Nearby Average Method

3.2.1 *apparent outdoor-indoor transmission class, apparent AOITC*(θ), *n*—of a building façade or façade element, a single-number rating calculated in accordance with Classification E1332 using measured values of apparent outdoor-indoor transmission loss at a specified angle or range of angles.

3.2.2 *apparent outdoor-indoor transmission loss, AOITL*(θ), *dB, n*—of a building façade or façade element, the value of outdoor-indoor transmission loss obtained on a test facade element as installed, in a specified frequency band, for a source at a specified angle θ or range of angles as measured from the normal to the center of the specimen surface, without flanking tests to identify or eliminate extraneous transmission paths.

3.2.2.1 Discussion—

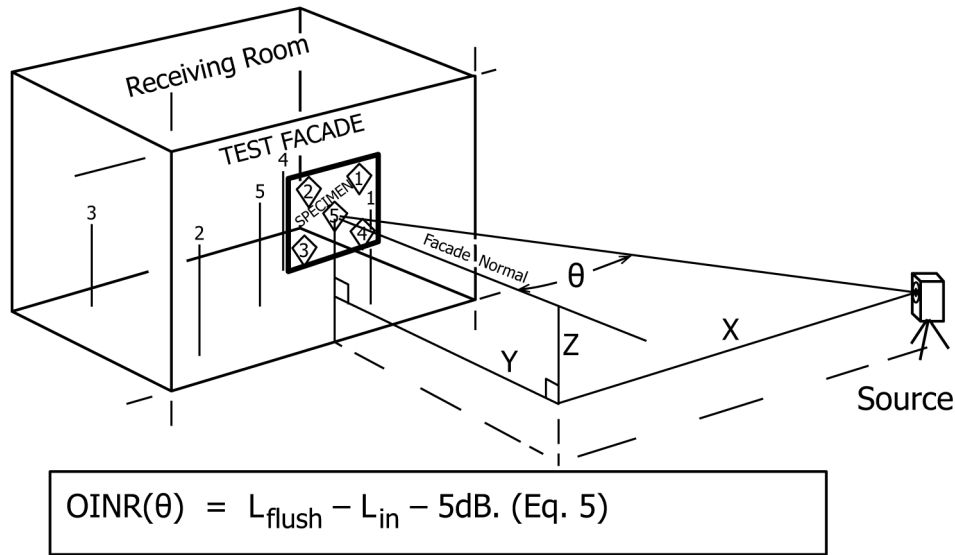

FIG. 3 Geometry—Flush Method

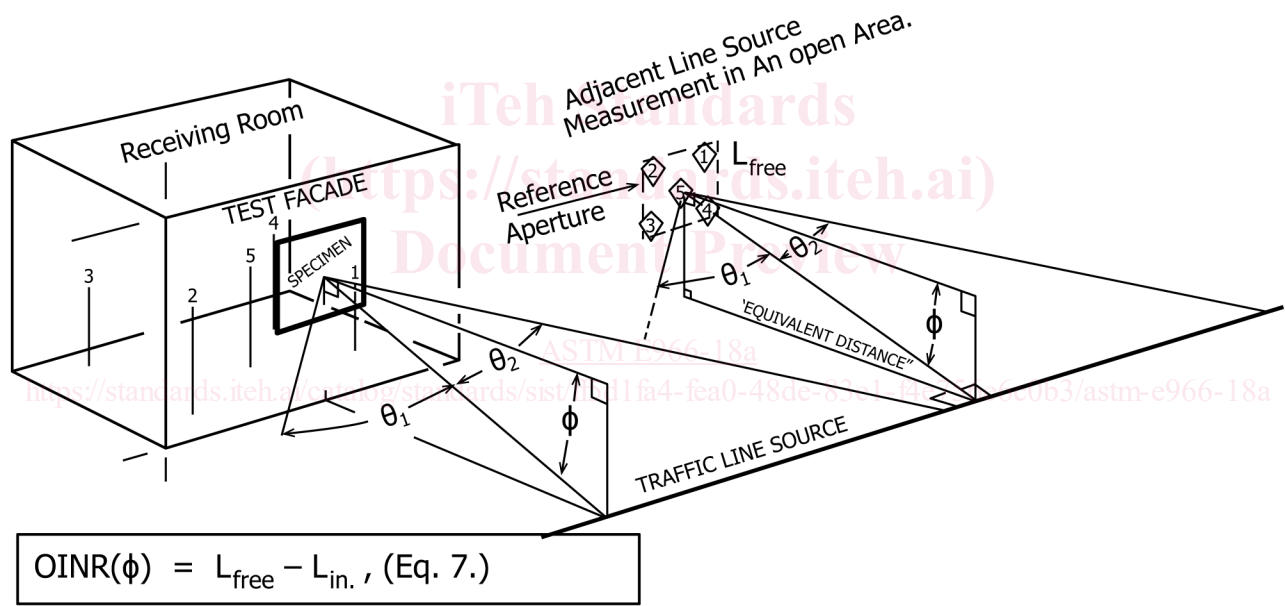

FIG. 4 Geometry—Equivalent Distance Method

All the sound power transmitted into the receiving room through both direct and flanking paths is attributed solely to the physical area of the test specimen. If flanking transmission is significant, the AOITL will be less than the actual OITL for the specimen.

3.2.3 *field outdoor-indoor transmission class, FOITC*(θ), n —of a building façade or façade element, the single number rating obtained by Classification E1332 with OITL values at a specified angle θ or range of angles.

3.2.4 *outdoor-indoor noise isolation class, OINIC* or *OINIC*(θ), n —of an enclosed space, a single-number rating calculated in accordance with Classification E1332 using values of outdoor-indoor noise reduction.

3.2.4.1 *Discussion*—

OINIC is an A-weighted level difference based on a specific spectrum defined in Classification E1332.

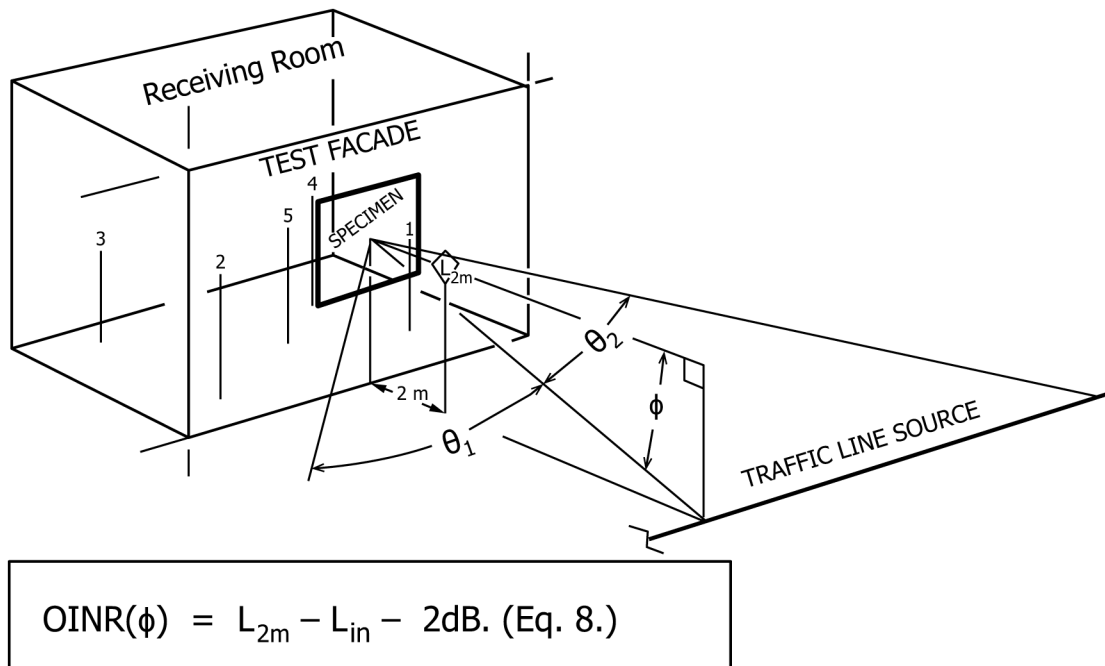

FIG. 5 Geometry—2 m (79 in.) Position Method

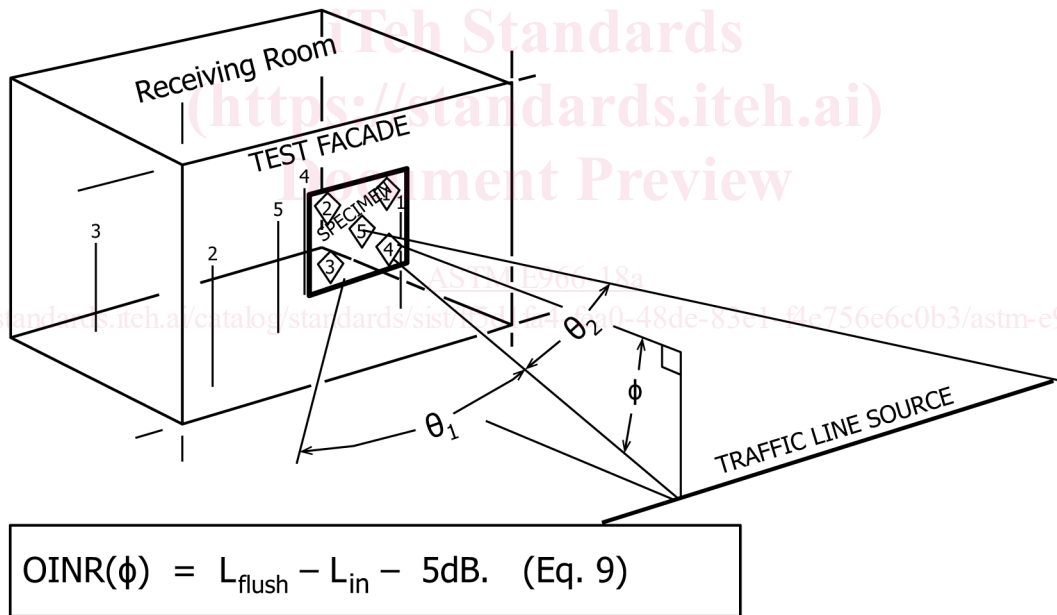

FIG. 6 Geometry and Formulas—Line Source Flush Method

3.2.5 outdoor-indoor noise reduction, $OINR$ or $OINR(\theta)$, dB, n —for a specified source angle of incidence or source sound distribution, the difference in a specified frequency band between the time average free-field sound pressure level at the exterior of a façade and the space-time average sound pressure level in a room of a building exposed to the outdoor sound through that façade.

3.2.5.1 Discussion—

The outdoor-indoor noise reduction has been known previously in this guide as the outdoor-indoor level reduction, OILR. For measured data, the $OINR(\theta)$ may be used to indicate results at a specific angle (θ) as discussed in 8.5. $OINR$ may be used to indicate the weighted average of measurements over a range of angles as discussed in 8.6 or a measurement result due to exposure to a line source as discussed in Section 9.

3.2.6 *outdoor-indoor transmission loss, OITL(θ), (dB), n —of a building façade or façade element, in a specified frequency band, for a source at a specified angle θ or range of angles as measured from the normal to the center of the specimen surface, ten times the common logarithm of the ratio of airborne sound power incident on the specimen to the sound power transmitted through it and radiated to the room interior.*

3.2.6.1 *Discussion—*

The unqualified term OITL(θ) signifies that flanking tests have been performed according to Annex A1 to verify that there was no significant flanking or leakage transmission. In the absence of such tests, the test result may be termed the AOITL(θ) (see 3.2.2).

3.2.7 *sound exposure level—*SEL in decibels where the “*” denotes the frequency weighting such as CSEL for C-weighting (understood to be A if absent).*

3.2.8 *one-third octave-band sound exposure—level one-third octave-band SEL(f), (dB), n —ten times the logarithm to the base ten of the ratio of a given time integral of squared instantaneous sound pressure in a specific one-third octave-band of center frequency f , over a stated time interval or event, to the product of the squared reference sound pressure of 20 micropascals and reference duration of one second.*

3.2.9 *traffic noise—noise emitted by moving transportation vehicles, such as cars, trucks, locomotives, or aircraft moving along an extended line path.*

4. Summary of Guide

4.1 This guide provides procedures to measure the reduction in sound level from the outdoors to an enclosed room, the outdoor-indoor level reduction, OINR, with a variety of sources and methods. With further measurements under restricted conditions using a loudspeaker source, a basic property of a facade or facade element, the outdoor-indoor transmission loss, OITL(θ), may be determined. This requires that the conditions of Annex A1 be met to demonstrate that flanking of sound around the test specimen is not significant. If it is not possible to meet the conditions of Annex A1, the AOITL(θ) is reported. These results measured with a loudspeaker will vary with the angle of the source θ as measured from the normal to the surface as shown in Fig. 7. The OINR(θ), the AOITL(θ), and the OITL(θ) may be reported for a variety of angles. The result using traffic noise, OINR(line, Φ), can depend on the incidence angle Φ , from the normal to the point at closest approach. See Fig. 8),

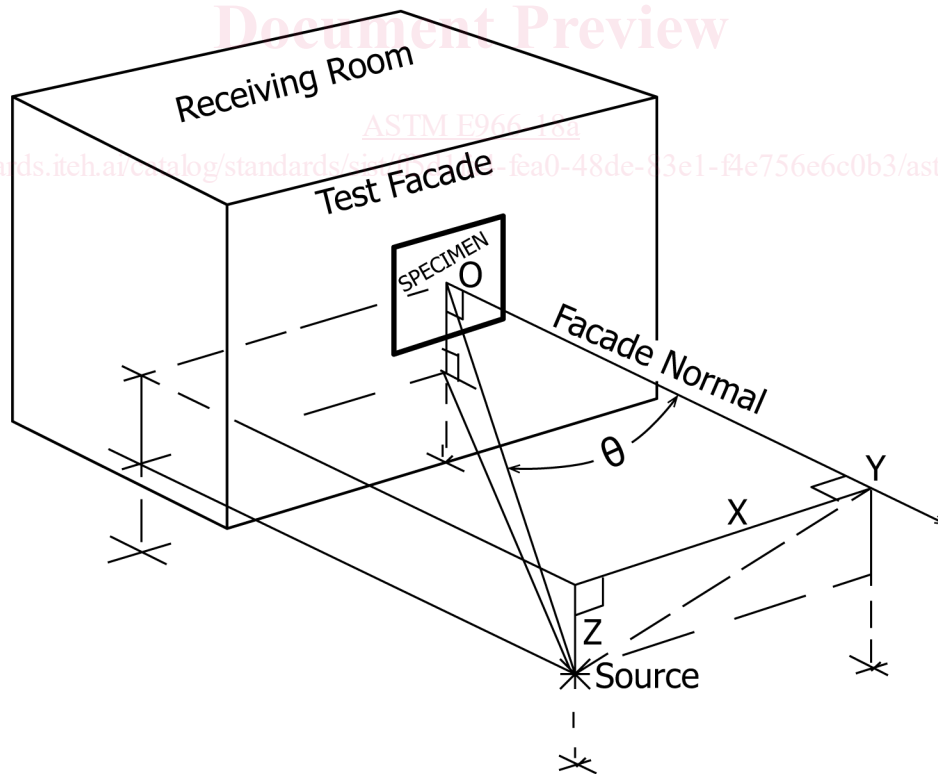

θ = angle of incidence.

FIG. 7 Source Location (*) and θ Definition