



Designation: **B539 – 02 (Reapproved 2013) B539 – 18**

# Standard Test Methods for Measuring Resistance of Electrical Connections (Static Contacts)<sup>1</sup>

This standard is issued under the fixed designation B539; the number immediately following the designation indicates the year of original adoption or, in the case of revision, the year of last revision. A number in parentheses indicates the year of last reapproval. A superscript epsilon ( $\epsilon$ ) indicates an editorial change since the last revision or reapproval.

## 1. Scope

1.1 These test methods cover equipment and techniques for measuring the resistance of static electrical connections such as wire terminations or splices, friction connectors, soldered joints, and wrapped-wire connections.

1.2 Measurements under two distinct levels of electrical loading are described. These levels are: (1) dry circuit, (2) and rated current. One or both of these levels of loading may be required in specific cases.

1.3 *This standard does not purport to address all of the safety concerns, if any, associated with its use. It is the responsibility of the user of this standard to become familiar with all hazards including those identified in the appropriate Material Safety Data Sheet (MSDS)(SDS) for this product/material as provided by the manufacturer, to establish appropriate safety, health, and environmental practices, and determine the applicability of regulatory limitations prior to use.*

1.4 *This international standard was developed in accordance with internationally recognized principles on standardization established in the Decision on Principles for the Development of International Standards, Guides and Recommendations issued by the World Trade Organization Technical Barriers to Trade (TBT) Committee.*

## 2. Referenced Documents

2.1 *ASTM Standards:*<sup>2</sup>

**B542 Terminology Relating to Electrical Contacts and Their Use**

**E122 Practice for Calculating Sample Size to Estimate, With Specified Precision, the Average for a Characteristic of a Lot or Process**

## 3. Terminology

3.1 *Definitions:*

3.1.1 See Terminology **B542** for definitions of contact resistance, film resistance, and constriction resistance.

3.1.2 *bulk resistance, n*—the resistance a contact assembly would have if it were solid metal of an identical geometry so that the nominal contact area offered zero resistance. When measuring *contact resistance* one attempts to include as little *bulk resistance* as possible in the measurement, by placing measuring probes as close to the contact interface as practical.

3.1.3 *connection resistance, n*—the resistance from the termination point on one end of a device containing static contacts, through the contacts to the termination point on the other end of the device. The termination point is the location on a terminal of a device where a wire or printed circuit path electrically connects to the terminal. This resistance is the value of resistance displayed by the device in a circuit application.

3.1.3.1 *Discussion*—

The term contact resistance is often used in commercial literature to indicate the connection resistance displayed by the device in a standard application. In the more rigorous usage of contact resistance, the connection resistance is the sum of the contact

<sup>1</sup> These test methods are under the jurisdiction of ASTM Committee **B02** on Nonferrous Metals and Alloys and are the direct responsibility of Subcommittee **B02.11** on Electrical Contact Test Methods.

Current edition approved Aug. 1, 2013; Nov. 1, 2018. Published August 2013; December 2018. Originally approved in 1970. Last previous edition approved in 2008; 2013 as B539 – 02 (2008); (2013). DOI: 10.1520/B0539-02R13; 10.1520/B0539-18.

<sup>2</sup> For referenced ASTM standards, visit the ASTM website, www.astm.org, or contact ASTM Customer Service at service@astm.org. For *Annual Book of ASTM Standards* volume information, refer to the standard's Document Summary page on the ASTM website.

resistance plus the bulk resistance of leads within the device that go to the static contacts from the point that the leads are connected to the external circuitry. Measurement of contact resistance independent of all bulk resistance is very difficult for most commercial devices.

3.1.4 *dry circuit, n*—a circuit in which the *open-circuit* voltage is less than or equal to 20 mV. Current is usually low in a *dry circuit*, but a *low-current circuit* is not necessarily a *dry circuit*. When the applied voltage (*open-circuit voltage*) is too low to cause any physical changes in the contact junction, such as break-down of thin insulating films or softening of contact asperities, the circuit is said to be a *dry circuit*.

3.1.5 *open-circuit voltage, n*—the steady-state voltage which would appear across the contacts if they were opened.

3.1.6 *static contacts, n*—electric junctions designed for infrequent separation and connection, and intended to perform their function only when contacting members are stationary relative to each other. This definition includes crimped, welded, brazed, riveted, or soldered joints; friction connections such as pin and socket connectors or taper pins, twisted-wire splices; and connections made with screws, or bolts and nuts between electrical wiring and components. The definition excludes relay contacts, slip rings and commutators, and switches and circuit breakers.

3.2 *Descriptions of Terms for Levels of Electrical Loading:*

3.2.1 *dry circuit, n*—This method provides for measurement of contact resistance under very low levels of electrical excitation, with applied voltages and currents selected to be too low to cause breakdown of thin oxide films or other contaminants in the contact interface or to cause formation of metallic bridges across the interface where none may otherwise exist. Dry circuit testing is intended to determine whether the test contact will function properly in circuits of arbitrarily low levels of electrical excitation. Dry circuit testing procedures should be used when the possibility of films or contaminants in the contact interface exists or when the test sample is ultimately intended for use in a low-level circuit. This testing must precede other tests on the same samples at high levels of electrical loading.

3.2.2 *rated current, n*—The rated current for a static contact device is determined or specified by the vendor or user of the device. The rated current may be large enough to cause significant heating of the test samples. When rated current measurements of contact resistance are required, using either ac or dc test currents, the procedures outlined for temperature stabilization in 9.5.3 must be followed.

#### 4. Summary of Test Methods

4.1 The test methods described herein are characterized as four-terminal resistance measuring techniques, wherein a measured and controlled test current is introduced into the sample using two “terminals” or connecting points, and two other points are selected on the sample across which a voltage drop is measured. This voltage drop, divided by the test current, is the effective overall resistance of the sample included between the voltage probes. The voltage-measuring points are chosen so as to measure as closely as possible the voltage drop due only to the contact resistance of the sample and to eliminate from the measurement as much as possible the resistance of the metal pieces comprising the contact and the resistance of the wires and connections used to introduce the test current into the sample.

4.2 Two different levels of test current are specified. The choice of which level to use is governed by the application and requirements of the electrical connection being tested. Electronic signal-circuit connections may require low-level (dry-circuit) testing, whereas power-handling wire connectors should be tested at rated current.

4.3 Either ac or dc test currents may be used, with appropriate instrumentation.

#### 5. Significance and Use

5.1 As stated in Terminology B542, contact resistance is comprised of a constriction resistance and a film resistance. When present, the latter of these is usually much greater in value and dominates the contact resistance. For a given contact spot, when the film resistance is zero or negligible the contact resistance for that spot is nearly the same as the constriction resistance and therefore, as a practical matter, has a minimum value which represents a clean metal-to-metal contact spot. As real contact surfaces exhibit varying degrees of roughness, real contacts are necessarily composed of many contact spots which are electrically parallel. In practical cases the clean metal-to-metal contact spots will carry most of the current and the total contact resistance is primarily dependent on the size and number of metallic contact spots present (see Note 1). In addition, acceptably low values of contact resistance are often obtained with true areas of contact being significantly less than the apparent contact area. This is the result of having a large number of small contact spots spread out over a relatively large apparent contact area.

NOTE 1—The term metallic contact as used here is intended to include the so called quasi-metallic contact spots as well. The latter case was discussed in *Electric Contacts* by Holm.<sup>3</sup>

5.2 The practical evaluation and comparison of electrical connections depend in large part on their contact resistance characteristics. On the one hand, the absolute value of contact resistance is greatly dependent on the amount of metallic contact

<sup>3</sup> Calculations and formulae for contact resistance of various types of contacts are covered very thoroughly in Holm’s *Electric Contacts*, 4th Edition, Springer-Verlag, New York.

established and indicates initially how efficient the system is in producing areas of metallic size and distribution of the metallic conducting spots within the apparent area of load-bearing contact. On the other hand, a comparison of the initial resistance to the resistance after aging indicates how stable the system is in maintaining the initial contact area. Both of these characteristics should be considered when evaluating contact systems. The criteria employed in evaluating contact resistance and stability are not a part of these test methods as they depend on specific applications and therefore, will not be quantitatively stated. However, an estimate of contact resistance<sup>3</sup> resulting from good metallic contact can be made for a given physical situation and used as a comparison to actual measurements to determine how effective the system is in establishing stable metallic contact. Resistances measured by these methods before, during and after simulated life tests are used as a means of determining the stability of contacts within a device.

**6. Interferences**

*6.1 Measurement of Low Resistance:*

6.1.1 Contact resistances are normally very small, ranging from microohms to a few milliohms in cases of practical interest. The measurement of resistance in this range requires special techniques to eliminate effects of thermal potentials, external interference, and resistance of connections and wires leading to the test sample.

6.1.2 The resistance-measuring procedures in these test methods are four-terminal techniques. Test current in the sample is measured and controlled, and made independent of the sample resistance. Voltage-measuring probes are attached to the sample so as to eliminate the effects of connections of the sample into the test circuit. If the purpose of the measurement is to determine the contact resistance, the voltage measuring probes are attached as close as feasible to the static contacts, so as to include as little of the bulk resistance of the sample as possible in the measurement of the contact resistance.

6.1.3 Two wire measurements of resistance are not suitable because connections to the sample will contribute part of the measured resistance, and these may be large, unknown, and variable.

6.1.4 Because the resistance being measured is often in the microohm or milliohm range, and it is determined by measuring the potential across the static contacts, the value of the potential is often in the microvolt or millivolt range. As a result, thermal potentials may be significant in relation to the potential being measured and appropriate measures are required to cancel or eliminate their effects.

6.1.5 In the dry circuit method, high potential may change a resistance by breaking down a film. Appropriate caution is required to obtain valid dry circuit resistance measurements including limiting the open circuit voltage of the measuring apparatus that is connected to the device under test.

*6.2 ac Versus dc Measurements:*

6.2.1 Either method described herein can be used with ac or dc test currents, with appropriate changes in instrumentation to correspond with the power supply. The methods are described as using dc test currents, and the following comments apply when ac is used.

6.2.2 ac measurements should be expressed as RMS unless otherwise defined in the test report. Take appropriate measures to isolate the measurements from stray signals, especially sixty hertz power line noise. Commercial resistance measuring instruments that use ac test currents generally are suitable providing that they meet other requirements of the standard.

**7. Apparatus and Test Circuits**

7.1 Fig. 1 shows the basic arrangement of a four wire circuit for measuring. In the illustration, the measured resistance is the resistance between the points where the voltmeter is attached to the test specimen, that is, between the points of V1 and V2. The measured resistance includes the contact resistance at the contact between the two rounded points and the bulk resistance out to

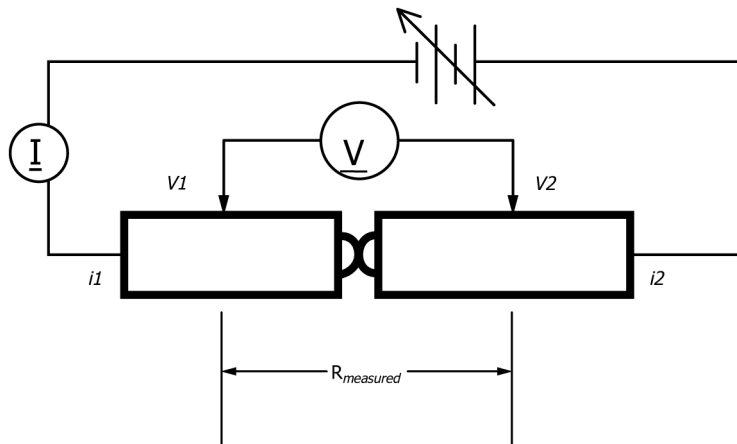

FIG. 1 Schematic Representation of 4 Wire Measurement Circuit

the point where the voltage probes touch the test specimen. To measure connection resistance, move the voltage probes away from the contact point to the very end of each contact member where the current leads are attached. To attempt to measure contact resistance, move the voltage probes as close as possible to the contact point. The equipment consists of the following elements:

7.1.1 *Power Supply*—A supply capable of providing the required current and, in the case of the dry circuit measurement capable of limiting the current to 100 milliamps and the open circuit voltage to 20mV. The supply may be dc or ac, but the voltage measuring device must match the type of current from the supply.

7.1.2 Voltmeters and ammeters built into power supplies may or may not meet the requirements of these methods with respect to accuracy or precision. External metering should be used when necessary.

7.1.3 Both output terminals of the dc supply must be isolated from the power line, the case of the supply, and the building ground. This prevents “ground loops” or undesired connections through ground, between the power supply and other measuring instruments (such as an electronic voltmeter) attached to the sample.

7.1.4 ~~The maximum current required in capacity of the power supply can must be estimated from sufficient Table 1, which gives rated currents for various wire-size terminations according to Military specifications for the highest rating of the devices being tested.~~

7.1.5 The output current of the power supply should be variable and readily and accurately adjustable.

7.2 *Current Measuring Device*—a meter, ac or dc, to match the power supply current type or suitable alternate measuring circuitry is needed. The accuracy of the device must be 1 % or better of the measured current. Some power supplies include measurement capability of sufficient accuracy. An external arrangement of a calibrated fixed resistor wired in series with the test current and a voltmeter across the resistor is suitable provided that it achieves the accuracy required.

7.3 *Reversing Switch*—Since millivolt-drop readings across the sample are to be taken with both forward and reverse dc current, a double-pole-double-throw switch of suitable current-handling capacity inserted in the current leads is used to reverse the current in the test specimen. Alternatively, some power supplies are programmable to reverse the current flow direction and the current may be reversed with this feature in the supply rather than with a separate switch.

7.4 *Millivoltmeter:*

7.4.1 A voltmeter with an accuracy of 1 % or better of the measured voltage. Generally, an accuracy of 10 microvolts will be adequate to meet this requirement and is readily available in modern bench instruments.

7.5 *Current and Voltage Probes:*

7.5.1 Current is introduced to the device in a way to best simulate how it flows when the device is in service. For example, if the device is normally connected with soldered wires, the same arrangement would be recommended as the manner that its resistance would be measured.

7.5.2 Voltage probes must be placed or attached so as to cause minimal change in the device or the current flow pattern through it. In general, small probes are preferred. If attachment by soldering or spot welding is selected, it should be performed with caution to minimize possible heating or contamination of the contact being measured.

7.5.3 In corrosion testing of stranded wire terminations the stranded wires often become corroded under the insulation covering for some distance along the wire. Subsequent resistance measurements are then difficult to make accurately because of a loss of strand-to-strand conductivity and the inability of a probe to contact all of the strands in the wire. A procedure to eliminate this difficulty involves the inclusion of a “potential-measuring point” on the wire in the form of a current equalizer (soldered spot, welded spot, strandgathering crimped sleeve) holding all of the strands together. The current equalizer should be far enough away from the terminal (at least 2.5 cm) so that the operation of applying it cannot affect the test joint. In the final result, the fact that a resistance equivalent to the added length of wire is included in the measurement should be considered.

## 8. Sampling

8.1 The sampling plans described below are based on statistical procedures presented in Practice E122.

8.2 Assuming normal statistics apply, a suitable sample size can be obtained from the following equation:

$$N = \left[ \frac{3\sigma_x/\bar{X}}{E/\bar{X}} \right]^2 \quad (1)$$

where:

$E/\bar{X}$  = maximum allowed sampling error, %, and

$3\sigma_x/\bar{X}$  = advance estimate of sample variation, % ( $\sigma_x$  = standard deviation,  $\bar{X}$  = mean).

8.2.1 For example: assume for small wire terminations (AWG 28 to AWG 20) where one inch of wire is included in the measured resistance  $3\sigma_x/\bar{X} = 15\%$  and for  $E/\bar{X} = 5\%$ , the minimum value of  $N = 9$  is obtained. If a sampling error of 3 % were chosen, then the sample size becomes  $N = 25$ . It should be noted that  $N$  is an estimate of the sample size required to statistically establish the mean response of a specimen for a prescribed sampling error and given sample variation. This test method, however, requires that the underlying statistical distributions be normal. If significant deviations from normality occur, then an analysis should be performed using more suitable statistics.