



Designation: D1319 – 18

Standard Test Method for Hydrocarbon Types in Liquid Petroleum Products by Fluorescent Indicator Adsorption¹

This standard is issued under the fixed designation D1319; the number immediately following the designation indicates the year of original adoption or, in the case of revision, the year of last revision. A number in parentheses indicates the year of last reapproval. A superscript epsilon (ϵ) indicates an editorial change since the last revision or reapproval.

This standard has been approved for use by agencies of the U.S. Department of Defense.

1. Scope*

1.1 This test method covers the determination of hydrocarbon types over the concentration ranges from 5 % to 99 % by volume aromatics, 0.3 % to 55 % by volume olefins, and 1 % to 95 % by volume saturates in petroleum fractions that distill below 315 °C. This test method may apply to concentrations outside these ranges, but the precision has not been determined. Samples containing dark-colored components that interfere in reading the chromatographic bands cannot be analyzed.

NOTE 1—For the determination of olefins below 0.3 % by volume, other test methods are available, such as Test Method D2710.

1.2 This test method is intended for use with full boiling range products. Cooperative data have established that the precision statement does not apply to narrow boiling petroleum fractions near the 315 °C limit. Such samples are not eluted properly, and results are erratic.

1.3 This test method includes a relative bias section based on Practice D6708 accuracy assessment between Test Method D1319 and Test Method D5769 for total aromatics in spark-ignition engine fuels as a possible Test Method D1319 alternative to Test Method D5769 for U.S. EPA spark-ignition engine fuel regulations reporting. The Practice D6708 derived correlation equation is only applicable for fuels in the total aromatic concentration range from 3.3 % to 34.4 % by volume as measured by Test Method D1319 and the distillation temperature T_{95} , at which 95 % of the sample has evaporated, ranges from 149.1 °C to 196.6 °C (300.3 °F to 385.8 °F) when tested according to Test Method D86.

1.3.1 The applicable Test Method D5769 range for total aromatics is 3.7 % to 29.4 % by volume as reported by Test Method D5769 and the distillation temperature T_{95} values, at which 95 % of the sample has evaporated, when tested

according to Test Method D86 is from 149.1 °C to 196.6 °C (300.3 °F to 385.8 °F).

1.4 The applicability of this test method to products derived from fossil fuels other than petroleum, such as coal, shale, or tar sands, has not been determined, and the precision statement may or may not apply to such products.

1.5 This test method has two precision statements depicted in tables. The first table is applicable to unleaded fuels that do not contain oxygenated blending components. It may or may not apply to automotive gasolines containing lead antiknock mixtures. The second table is applicable to oxygenate blended (for example, MTBE, ethanol) automotive spark ignition fuel samples with a concentration range of 13 % to 40 % by volume aromatics, 4 % to 33 % by volume olefins, and 45 % to 68 % by volume saturates.

1.6 The oxygenated blending components, methanol, ethanol, methyl-*tert*-butylether (MTBE), *tert*-amylmethylether (TAME), and ethyl-*tert*-butylether (ETBE), do not interfere with the determination of hydrocarbon types at concentrations normally found in commercial blends. These oxygenated components are not detected since they elute with the alcohol desorbent. Other oxygenated compounds shall be individually verified. When samples containing oxygenated blending components are analyzed, correct the results to a total-sample basis.

1.7 **WARNING**—Mercury has been designated by many regulatory agencies as a hazardous substance that can cause serious medical issues. Mercury, or its vapor, has been demonstrated to be hazardous to health and corrosive to materials. Use Caution when handling mercury and mercury-containing products. See the applicable product Safety Data Sheet (SDS) for additional information. The potential exists that selling mercury or mercury-containing products, or both, is prohibited by local or national law. Users must determine legality of sales in their location.

1.8 The values stated in SI units are to be regarded as standard. The values given in parentheses after SI units are provided for information only and are not considered standard.

¹ This test method is under the jurisdiction of ASTM Committee D02 on Petroleum Products, Liquid Fuels, and Lubricants and is the direct responsibility of Subcommittee D02.04.0C on Liquid Chromatography.

Current edition approved Oct. 1, 2018. Published December 2018. Originally approved in 1954. Last previous edition approved in 2015 as D1319 – 15. DOI: 10.1520/D1319-18.

*A Summary of Changes section appears at the end of this standard

1.9 This standard does not purport to address all of the safety concerns, if any, associated with its use. It is the responsibility of the user of this standard to establish appropriate safety, health, and environmental practices and determine the applicability of regulatory limitations prior to use. For specific warning statements, see Section 7, 8.1, and 10.5.

1.10 This international standard was developed in accordance with internationally recognized principles on standardization established in the Decision on Principles for the Development of International Standards, Guides and Recommendations issued by the World Trade Organization Technical Barriers to Trade (TBT) Committee.

2. Referenced Documents

2.1 ASTM Standards:²

D86 Test Method for Distillation of Petroleum Products and Liquid Fuels at Atmospheric Pressure

D1655 Specification for Aviation Turbine Fuels

D2710 Test Method for Bromine Index of Petroleum Hydrocarbons by Electrometric Titration

D3663 Test Method for Surface Area of Catalysts and Catalyst Carriers

D4057 Practice for Manual Sampling of Petroleum and Petroleum Products

D4815 Test Method for Determination of MTBE, ETBE, TAME, DIPE, tertiary-Amyl Alcohol and C₁ to C₄ Alcohols in Gasoline by Gas Chromatography

D5599 Test Method for Determination of Oxygenates in Gasoline by Gas Chromatography and Oxygen Selective Flame Ionization Detection

D5769 Test Method for Determination of Benzene, Toluene, and Total Aromatics in Finished Gasolines by Gas Chromatography/Mass Spectrometry

D6708 Practice for Statistical Assessment and Improvement of Expected Agreement Between Two Test Methods that Purport to Measure the Same Property of a Material

E11 Specification for Woven Wire Test Sieve Cloth and Test Sieves

2.2 Other Standards:

GC/OFID EPA Test Method—Oxygen and Oxygenate Content Analysis³

BS 410–1:2000 Test sieves. Technical requirements and testing. Test sieves of metal wire cloth⁴

3. Terminology

3.1 Definitions of Terms Specific to This Standard:

3.1.1 *aromatics*—the volume percent of monocyclic and polycyclic aromatics, plus aromatic olefins, some dienes, compounds containing sulfur and nitrogen, or higher boiling oxygenated compounds (excluding those listed in 1.6).

3.1.2 *olefins*—the volume percent of alkenes, plus cycloalkenes, and some dienes.

3.1.3 *saturates*—the volume percent of alkanes, plus cycloalkanes.

4. Summary of Test Method

4.1 Approximately 0.75 mL of sample is introduced into a special glass adsorption column packed with activated silica gel. A small layer of the silica gel contains a mixture of fluorescent dyes. When all the sample has been adsorbed on the gel, alcohol is added to desorb the sample down the column. The hydrocarbons are separated in accordance with their adsorption affinities into aromatics, olefins, and saturates. The fluorescent dyes are also separated selectively, with the hydrocarbon types, and make the boundaries of the aromatic, olefin, and saturate zones visible under ultraviolet light. The volume percentage of each hydrocarbon type is calculated from the length of each zone in the column.

5. Significance and Use

5.1 The determination of the total volume percent of saturates, olefins, and aromatics in petroleum fractions is important in characterizing the quality of petroleum fractions as gasoline blending components and as feeds to catalytic reforming processes. This information is also important in characterizing petroleum fractions and products from catalytic reforming and from thermal and catalytic cracking as blending components for motor and aviation fuels. This information is also important as a measure of the quality of fuels, such as specified in Specification **D1655**.

6. Apparatus

6.1 *Adsorption Columns*, with precision bore (“true bore” IP designation) tubing, as shown on the right in Fig. 1, made of glass and consisting of a charger section with a capillary neck, a separator section, and an analyzer section; or with standard wall tubing, as shown on the left in Fig. 1. Refer to Table 1 for column tolerance limits.

6.1.1 The inner diameter of the analyzer section for the precision bore tubing shall be 1.60 mm to 1.65 mm. In addition the length of an approximately 100 mm thread of mercury shall not vary by more than 0.3 mm in any part of the analyzer section. In glass-sealing the various sections to each other, long-taper connections shall be made instead of shouldered connections. Support the silica gel with a small piece of glass wool located between the ball and socket of the 12/2 spherical joint and covering the analyzer outlet. The column tip attached to the 12/2 socket shall have a 2 mm internal diameter. Clamp the ball and socket together and ensure that the tip does not tend to slide from a position in a direct line with the analyzer section during the packing and subsequent use of the column. Commercial compression-type connectors may be used to couple the bottom of the separator section (which has been cut square), to the disposable 3 mm analyzer section, provided that the internal geometry is essentially similar to the aforementioned procedure and provides for a smooth physical transition from the inner diameters of the two glass column sections.

² For referenced ASTM standards, visit the ASTM website, www.astm.org, or contact ASTM Customer Service at service@astm.org. For *Annual Book of ASTM Standards* volume information, refer to the standard’s Document Summary page on the ASTM website.

³ Code of Federal Regulations, Part 80 of Title 40, 80.46 (g); also published in the Federal Register, Vol 59, No. 32, Feb. 16, 1994, p. 7828. No longer available.

⁴ Available from British Standards Institution (BSI), 389 Chiswick High Rd., London W4 4AL, U.K., http://www.bsigroup.com.

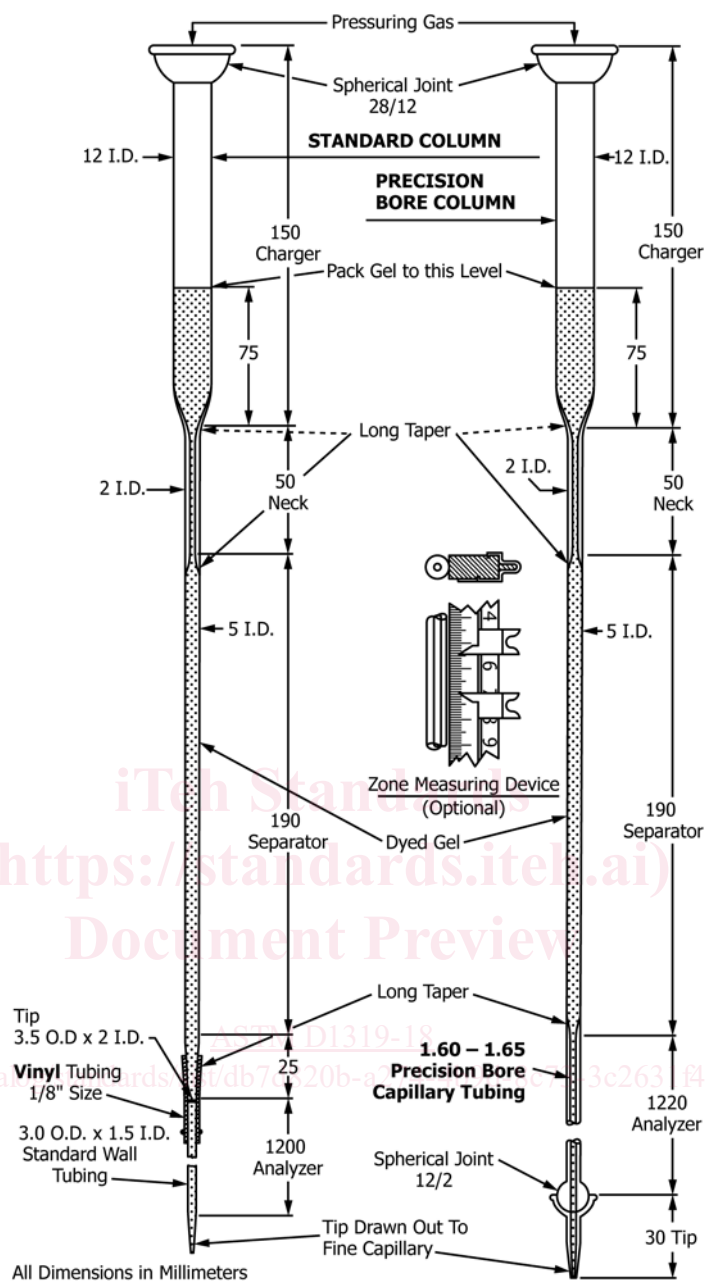

FIG. 1 Adsorption Columns with Standard Wall (left) and Precision Bore (right) Tubing in Analyzer Section

Similar commercial compression-type connectors may be employed at the terminal end of the 3 mm analyzer section, having an integral porous support to retain the silica gel.

6.1.2 For convenience, adsorption columns with standard wall tubing, as shown on the left in Fig. 1, can be used. When using standard wall tubing for the analyzer section, it is necessary to select tubing of uniform bore and to provide a leakproof connection between the separator and the analyzer sections. Calibrations of standard wall tubing would be impractical; however, any variations of 0.5 mm or greater, as measured by ordinary calipers, in the outside diameter along the tube can be taken as an indication of irregularities in the inner diameter and such tubing should not be used. Prepare the glassware to retain the gel. One way to accomplish this is to

draw out one end of the tubing selected for the analyzer section to a fine capillary. Connect the other end of the analyzer section to the separator section with a suitable length of vinyl tubing, making certain that the two glass sections touch. A 30 mm ± 5 mm length of vinyl tubing has been found to be suitable. To ensure a leakproof glass-to-vinyl seal with the analyzer section, it is necessary to heat the upper end of the analyzer section until it is just hot enough to melt the vinyl, then insert the upper end of the analyzer section into the vinyl sleeve. Alternatively, this seal can be made by securing the vinyl sleeve to the analyzer section by wrapping it tightly with soft wire. Commercial compression-type connectors may be used to couple the bottom of the separator section (which has been cut square), to the 3 mm analyzer section, provided that the

TABLE 1 Tolerance Limits to Column Dimensions

Standard Column Dimensions	
Charger Section	
Inside diameter = 12 mm ± 2 mm	
Pack gel to this level = approximately 75 mm	
Overall length = 150 mm ± 5 mm	
Neck Section	
Inside diameter = 2 mm ± 0.5 mm	
Overall length = 50 mm ± 5 mm	
Separator Section	
Inside diameter = 5 mm ± 0.5 mm	
Overall length = 190 mm ± 5 mm	
Long taper section below separator	
Tip outside diameter = 3.5 mm ± 0.5 mm	
Tip inside diameter = 2 mm ± 0.5 mm	
Overall length = 25 mm ± 2 mm	
Analyzer Section	
Inside diameter = 1. mm5 ± 0.5 mm	
Standard wall tubing	
Overall length = 1200 mm ± 30 mm	
Precision Bore Column Dimensions	
Charger section	
Inside diameter = 12 mm ± 2 mm	
Pack gel to this level = approximately 75 mm	
Overall length = 150 mm ± 5 mm	
Neck Section	
Inside diameter = 2 mm ± 0.5 mm	
Overall length = 50 mm ± 5 mm	
Separator Section	
Inside diameter = 5 mm ± 0.5 mm	
Overall length = 190 mm ± 5 mm	
Analyzer Section	
Inside diameter = 1.60 mm -1.65 mm	
Overall length = 1200 mm ± 30 mm	
Tip	
Overall length = 30 mm ± 5 mm	

internal geometry is essentially similar to the aforementioned procedure and provides for a smooth physical transition from the inner diameters of the two glass column sections. Similar commercial compression-type connectors may be employed at the terminal end of the 3 mm analyzer section having an integral porous support to retain the silica gel.

6.1.3 An alternative pressuring gas connection is shown in Fig. 2. Otherwise, all adsorption column dimensions and requirements are unchanged.

6.2 *Zone-Measuring Device*—The zones may be marked with a glass-writing pencil and the distances measured with a meter rule, with the analyzer section lying horizontally. Alternatively, the meter rule may be fastened adjacent to the column. In this case, it is convenient to have each rule fitted with four movable metal index clips (Fig. 1) for marking zone boundaries and measuring the length of each zone.

6.3 *Ultraviolet Light Source*, with radiation predominantly at 365 nm is required. A convenient arrangement consists of one or two 915 mm or 1220 mm units mounted vertically along the apparatus. Adjust to give the best fluorescence.

6.4 *Electric Vibrator*, for vibrating individual columns or the frame supporting multiple columns.

6.5 *Hypodermic Syringe*, 1 mL, graduated to 0.01 mL or 0.02 mL, with needle 102 mm in length. Needles of No. 18 gauge, 20 gauge, or 22 gauge are satisfactory.

6.6 *Regulator(s)*, capable of adjusting and maintaining the pressure within the 0 kPa to 103 kPa delivery range.

7. Reagents and Materials

7.1 *Silica Gel*,⁵ manufactured to conform to the specifications shown in Table 2. To be suitable for use, dry the gel in a shallow vessel at 175 °C for 3 h. Transfer the dried gel to an air tight container while still hot, and protect it thereafter from atmospheric moisture.

NOTE 2—Some batches of silica gel that otherwise meet specifications have been found to produce olefin boundary fading. The exact reason for this phenomenon is unknown but will affect accuracy and precision.

7.2 *Fluorescent Indicator Dyed Gel*—A standard dyed gel,^{5,6} consisting of a mixture of recrystallized Petrol Red AB4 and purified portions of the olefin and aromatic dyes obtained by chromatographic adsorption, following a definite, uniform procedure, and deposited on silica gel. The dyed gel shall be stored in a dark place under an atmosphere of nitrogen. When stored under these conditions, the dyed gel can have a shelf life of at least five years. It is recommended that portions of the dyed gel be transferred as required to a smaller working vial from which the dyed gel is routinely taken for analyses.

7.3 *Isoamyl Alcohol*, (3-methyl-1-butanol) 99 %. (**Warning**—Flammable. Health hazard.)

7.4 *Isopropyl Alcohol*, (2-propanol) minimum 99 % purity. (**Warning**—Flammable. Health hazard.)

7.5 *Pressuring Gas*—Air (or nitrogen) delivered to the top of the column at pressures controllable over the range from 0 kPa to 103 kPa gauge. (**Warning**—Compressed gas under high pressure.)

7.6 *Acetone*, reagent grade, residue free. (**Warning**—Flammable. Health hazard.)

7.7 *Buffer Solutions*, pH 4 and 7.

8. Sampling

8.1 Obtain a representative sample in accordance with sampling procedures in Practice D4057. For samples that would meet volatility conditions of Group 2 or less of Test Method D86, ensure that the sample is maintained at a temperature of ≤4°C when opening or transferring the sample. (**Warning**—Flammable. Health hazard.)

9. Preparation of Apparatus

9.1 Mount the apparatus assembly in a darkened room or area to facilitate observation of zone boundaries. For multiple determinations, assemble an apparatus that includes the ultraviolet light source, a rack to hold the columns, and a gas manifold system providing a connection to the desired number of columns.

10. Procedure

10.1 Ensure that the silica gel is tightly packed in the column and charger section (up to the appropriate level), which

⁵ If you are aware of alternative suppliers, please provide this information to ASTM International Headquarters. Your comments will receive careful consideration at a meeting of the responsible technical committee,¹ which you may attend.

⁶ The sole source of supply of the standard dyed gel known to the committee at this time is produced by UOP LLC, and distributed by Advanced Specialty Gas Equipment Inc, 241 Lackland Drive, Middlesex, New Jersey 08846. Request "FIA Standard Dyed Gel," UOP LLC Product No. 80675.