



Designation: G97 – 18

Standard Test Method for Laboratory Evaluation of Magnesium Sacrificial Anode Test Specimens for Underground Applications¹

This standard is issued under the fixed designation G97; the number immediately following the designation indicates the year of original adoption or, in the case of revision, the year of last revision. A number in parentheses indicates the year of last reapproval. A superscript epsilon (ϵ) indicates an editorial change since the last revision or reapproval.

1. Scope

1.1 This test method covers a laboratory procedure that measures the two fundamental performance properties of magnesium sacrificial anode test specimens operating in a saturated calcium sulfate, saturated magnesium hydroxide environment. The two fundamental properties are electrode (oxidation) potential and ampere hours (Ah) obtained per unit mass of specimen consumed. Magnesium anodes installed underground are usually surrounded by a backfill material that typically consists of 75 % gypsum ($\text{CaSO}_4 \cdot 2\text{H}_2\text{O}$), 20 % bentonite clay, and 5 % sodium sulfate (Na_2SO_4). The calcium sulfate, magnesium hydroxide test electrolyte simulates the long term environment around an anode installed in the gypsum-bentonite-sodium sulfate backfill.

1.2 This test method is intended to be used for quality assurance by anode manufacturers or anode users. However, long term field performance properties may not be identical to property measurements obtained using this laboratory test.

NOTE 1—Refer to Terminology G193 for terms used in this test method.

1.3 The values stated in SI units are to be regarded as standard. The values given in parentheses after SI units are provided for information only and are not considered standard.

1.4 *This standard does not purport to address all of the safety concerns, if any, associated with its use. It is the responsibility of the user of this standard to establish appropriate safety, health, and environmental practices and determine the applicability of regulatory limitations prior to use.* For specific precautions, See Section 8 and Paragraph 9.1.1.

1.5 *This international standard was developed in accordance with internationally recognized principles on standardization established in the Decision on Principles for the Development of International Standards, Guides and Recommendations issued by the World Trade Organization Technical Barriers to Trade (TBT) Committee.*

2. Referenced Documents

2.1 *ASTM Standards:*²

- D1193 Specification for Reagent Water
- E691 Practice for Conducting an Interlaboratory Study to Determine the Precision of a Test Method
- G3 Practice for Conventions Applicable to Electrochemical Measurements in Corrosion Testing
- G16 Guide for Applying Statistics to Analysis of Corrosion Data
- G193 Terminology and Acronyms Relating to Corrosion
- G215 Guide for Electrode Potential Measurement

2.2 *American National Standard:*

- ANSI/NFPA 480 Storage, Handling, and Processing of Magnesium Solids and Powders, 1998 Edition³

3. Terminology

3.1 *Definitions*—The terminology used herein shall be in accordance with Terminology G193.

4. Summary of Test Method

4.1 A known direct current is passed through test cells connected in series. Each test cell consists of a pre-weighed test magnesium alloy anode specimen, a steel pot container cathode, and a known electrolyte. Test specimen oxidation potential is measured several times during the 14-day test and 1 h after the current is turned off at the end of the test. The total Ah passed through the cells are measured. At the conclusion of the test, each test specimen is cleaned and weighed. The Ah obtained per unit mass of specimen lost is calculated.

5. Significance and Use

5.1 This test is a guide for evaluating magnesium anodes. The degree of correlation between this test and service performance has not been fully determined.

¹ This test method is under the jurisdiction of ASTM Committee G01 on Corrosion of Metals and is the direct responsibility of Subcommittee G01.10 on Corrosion in Soils.

Current edition approved Nov. 1, 2018. Published December 2018. Originally approved in 1989. Last previous edition approved in 2013 as G97 – 97 (2013). DOI: 10.1520/G0097-18.

² For referenced ASTM standards, visit the ASTM website, www.astm.org, or contact ASTM Customer Service at service@astm.org. For *Annual Book of ASTM Standards* volume information, refer to the standard's Document Summary page on the ASTM website.

³ Available from National Fire Protection Association (NFPA), 1 Batterymarch Park, Quincy, MA 02169-7471, <http://www.nfpa.org>.

5.2 Test specimens from the same casting may not be identical because of inhomogeneities in the casting. A method of ensuring that identical test specimens are being evaluated is to retest a test specimen. The surface of the test specimen should be smoothed by machining before retesting. The new diameter should be measured and the test current adjusted so that the retest current density is 0.039 mA/cm² (0.25 mA/in.²).

5.3 The values of potential and Ah per unit mass consumed as measured by this test method, may not agree with those found in field applications. It is unlikely that field results of Ah per unit mass consumed would ever be greater than those measured in this test. However, actual test comparisons are not sufficient to allow precise correlation of laboratory and field results.

6. Apparatus

- 6.1 The basic test equipment consists of the following:
 - 6.1.1 *Direct Current Power Source*, (optional), capable of delivering at least 2 mA and 12 V.
 - 6.1.2 *Steel Cathode Test Pot*, as shown in Fig. 1.
 - 6.1.3 *Copper Coulometer*, as shown in Fig. 2, or *Electronic Coulometer*.
 - 6.1.4 *Saturated Calomel Reference Electrode*.
 - 6.1.5 *Electrometer*, with an input impedance of 10⁷ or greater ohms.
 - 6.1.6 *Balance*, 100-g capacity with 0.1 mg sensitivity.
 - 6.1.7 *Drying Oven*, with temperature capability of 110°C (230°F) or higher.

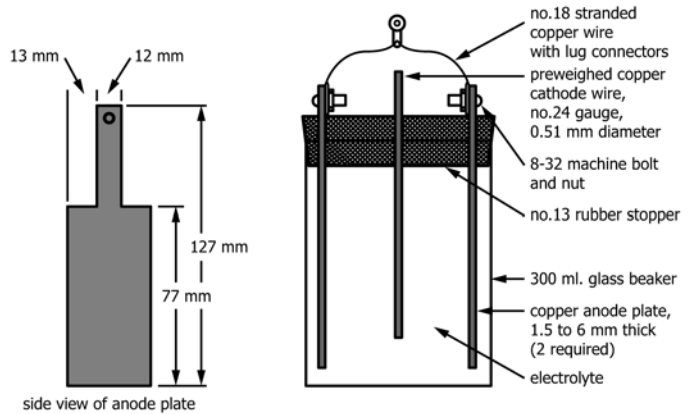

FIG. 2 Copper Coulometer

7. Reagents

7.1 *Test Electrolyte, Saturated Calcium Sulfate-Magnesium Hydroxide Solution*—Add 5.0 g of reagent grade CaSO₄·2H₂O, 0.1 g of reagent grade Mg(OH)₂, to 1000 mL of Type IV or better reagent grade water (see Specification D1193).

7.2 *Coulometer Solution*—Add 235 g of reagent grade CuSO₄·5H₂O, 27 mL 98 % H₂SO₄, 50 cm³ undenatured ethyl alcohol to 900 mL of Type IV or better reagent grade water.

7.3 *Anode Cleaning Solution*—Add 250 g of reagent grade CrO₃ to 1000 mL of Type IV or better reagent grade water.

8. Precautions

8.1 Eye protection and skin protection are required when handling the coulometer solution and when handling the cleaning solution. Test specimen cleaning should be done in a ventilated laboratory hood.

8.2 Local, state, and federal regulations should be complied with in disposing of used cleaning solution.

9. Specimen Preparation

9.1 Fig. 3 shows typical test specimen selection and preparation from a cast anode. Since all sizes and shapes of cast anodes are not shown, the sampling is only illustrative. Test specimens are obtained across the width of a cast anode and approximately 13 mm (0.51 in.) from the edge. Machine each test specimen from a sawed, 180 mm (7.1 in.) long, 16 mm (0.63 in.) square cross section portion of the cast anode. Dry machine the square cross section, which should be marked with a stamped identification number, down to 12.7 mm (0.50 in.) diameter using a machining speed of 800 r/min, a feed rate of 0.5 mm (0.02 in.) per revolution, and a depth of cut of 1.9 mm (0.07 in.) or less. Cut the machined test specimen to a 152 mm (6 in.) length and machine-face one end.

9.1.1 Magnesium fines produced during cutting and machining operations can present a fire hazard. ANSI/NFPA 480 should be consulted for procedures for handling magnesium.

9.1.2 Band saws and power hacksaws with the following characteristics are recommended for use on magnesium:

9.1.2.1 *Blade pitch (teeth/cm)*—Band saw = 1.6 to 2.4, power hacksaw = 0.8 to 2.4.

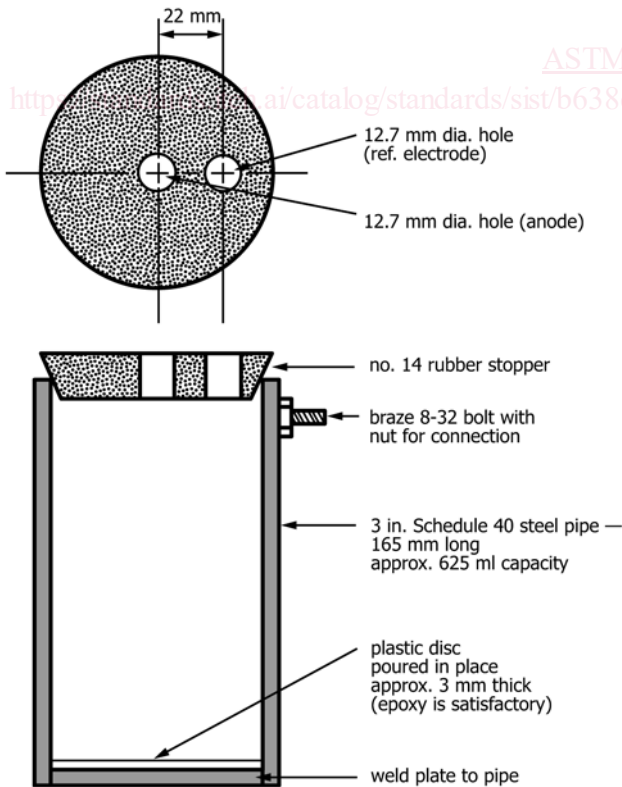

FIG. 1 Detail of Test Pot