



SLOVENSKI STANDARD

SIST EN 14420-6:2005

01-marec-2005

Cevni fitingi z objemkami - 6. del: Spojke za TW cisterne

Hose fittings with clamp units - Part 6: TW tank truck couplings

Schlaucharmaturen mit Klemmfassungen - Teil 6: TW Tankwagen-Kupplungen

Raccords pour flexibles avec demi-coquille - Partie 6: Raccords TW pour camion citerne

Ta slovenski standard je istoveten z: **EN 14420-6:2004**

[SIST EN 14420-6:2005](https://standards.iteh.ai/catalog/standards/sist/f7b8f61e-6f34-4df6-b279-0dbb75056b1f/sist-en-14420-6-2005)

<https://standards.iteh.ai/catalog/standards/sist/f7b8f61e-6f34-4df6-b279-0dbb75056b1f/sist-en-14420-6-2005>

ICS:

23.040.60 Prirobnice, oglavki in spojni elementi Flanges, couplings and joints

SIST EN 14420-6:2005

en

iTeh STANDARD PREVIEW
(standards.iteh.ai)

[SIST EN 14420-6:2005](#)

<https://standards.iteh.ai/catalog/standards/sist/f7b8f61e-6f34-4df6-b279-0dbb75056b1f/sist-en-14420-6-2005>

EUROPEAN STANDARD
NORME EUROPÉENNE
EUROPÄISCHE NORM

EN 14420-6

November 2004

ICS 23.040.70

English version

Hose fittings with clamp units - Part 6: TW tank truck couplings

Raccords pour flexibles avec demi-coquille - Partie 6:
Raccords TW pour camion citerne

Schlaucharmaturen mit Klemmfassungen - Teil 6: TW
Tankwagen-Kupplungen

This European Standard was approved by CEN on 30 September 2004.

CEN members are bound to comply with the CEN/CENELEC Internal Regulations which stipulate the conditions for giving this European Standard the status of a national standard without any alteration. Up-to-date lists and bibliographical references concerning such national standards may be obtained on application to the Central Secretariat or to any CEN member.

This European Standard exists in three official versions (English, French, German). A version in any other language made by translation under the responsibility of a CEN member into its own language and notified to the Central Secretariat has the same status as the official versions.

CEN members are the national standards bodies of Austria, Belgium, Cyprus, Czech Republic, Denmark, Estonia, Finland, France, Germany, Greece, Hungary, Iceland, Ireland, Italy, Latvia, Lithuania, Luxembourg, Malta, Netherlands, Norway, Poland, Portugal, Slovakia, Slovenia, Spain, Sweden, Switzerland and United Kingdom.

STANDARD PREVIEW
(standards.iteh.ai)

SIST EN 14420-6:2005
<https://standards.iteh.ai/catalog/standards/sist/f7b8f61e-6f34-4df6-b279-0dbb75056b1f/sist-en-14420-6-2005>



EUROPEAN COMMITTEE FOR STANDARDIZATION
COMITÉ EUROPÉEN DE NORMALISATION
EUROPÄISCHES KOMITEE FÜR NORMUNG

Management Centre: rue de Stassart, 36 B-1050 Brussels

Contents

	page
1	Scope4
2	Normative references4
3	Survey4
4	Dimensions, designations5
4.1	Hose fittings with TW couplings5
4.1.1	General.....5
4.1.2	Hose tail with female TW coupling.....6
4.1.3	Hose tail with male TW coupling.....7
4.1.4	Protecting ring8
4.2	Male coupling (type VK)9
4.2.1	General.....9
4.2.2	Components10
4.3	Female coupling (type MK)12
4.3.1	Female coupling (type MK) DN 50 and DN 8012
4.3.2	Female coupling (type MK) DN 10013
4.3.3	Designation13
4.3.4	Components14
4.4	Dust cap (type MB)19
4.4.1	General.....19
4.4.2	Components20
4.5	Dust plug (type VB).....22
4.5.1	General.....22
4.5.2	Components23
5	Materials26
5.1	General.....26
5.2	Hose tail types MKST and VKST26
5.3	Protecting rings of hose tail type MKST and VKST26
5.4	Thread sealing ring of male coupling type VK26
5.5	Fastening component of female coupling type MK27
5.6	Sealing ring of female coupling type MK27
6	Design27
7	Type approval testing and quality control27
7.1	General.....27
7.2	Testing for trueness to gauge size28
8	Marking28
9	Fitting of hose couplings28
Annex A (normative)	Gauges for TW tank truck couplings.....29
A.1	General.....29
A.2	Design; designation, dimensions and materials29
A.2.1	General.....29
A.2.2	Gauge for sealing ring.....30
A.2.3	Gauge for tension rings34
A.2.4	Gauge for curved pieces and plugs.....37
A.2.5	Calliper for caps.....40
A.3	Marking42
Bibliography43

iTech STANDARD PREVIEW
(standards.itech.ai)

[SIST EN 14420-6:2005](https://standards.itech.ai/catalog/standards/sist/17b81b1e-6134-4d16-b279-0dbb75056b11/sist-en-14420-6-2005)

[https://standards.itech.ai/catalog/standards/sist/17b81b1e-6134-4d16-b279-](https://standards.itech.ai/catalog/standards/sist/17b81b1e-6134-4d16-b279-0dbb75056b11/sist-en-14420-6-2005)

[0dbb75056b11/sist-en-14420-6-2005](https://standards.itech.ai/catalog/standards/sist/17b81b1e-6134-4d16-b279-0dbb75056b11/sist-en-14420-6-2005)

Foreword

This document (EN 14420-6:2004) has been prepared by Technical Committee CEN/TC 218 "Rubber and plastics hoses and hose assemblies", the secretariat of which is held by BSI.

This European Standard shall be given the status of a national standard, either by publication of an identical text or by endorsement, at the latest by May 2005, and conflicting national standards shall be withdrawn at the latest by May 2005.

EN 14420-1, *Hose fittings with clamp units — Part 1: Requirements, survey, designation and testing*

EN 14420-2, *Hose fittings with clamp units — Part 2: Hose side parts of hose tail*

EN 14420-3, *Hose fittings with clamp units — Part 3: Clamp units, bolted or pinned*

EN 14420-4, *Hose fittings with clamp units — Part 4: Flange connections*

EN 14420-5, *Hose fittings with clamp units — Part 5: Threaded connections*

EN 14420-6, *Hose fittings with clamp units — Part 6: TW tank truck couplings*

EN 14420-7, *Hose fittings with clamp units — Part 7: Cam locking couplings*

EN 14420-8, *Hose fittings with clamp units — Part 8: Symmetrical half couplings (Guillemin system)*

iTeh STANDARD PREVIEW
(standards.iteh.ai)

According to the CEN/CENELEC Internal Regulations, the national standards organizations of the following countries are bound to implement this European Standard: Austria, Belgium, Cyprus, Czech Republic, Denmark, Estonia, Finland, France, Germany, Greece, Hungary, Iceland, Ireland, Italy, Latvia, Lithuania, Luxembourg, Malta, Netherlands, Norway, Poland, Portugal, Slovakia, Slovenia, Spain, Sweden, Switzerland and United Kingdom

EN 14420-6:2004 (E)**1 Scope**

This document specifies the design, materials and dimensions for hose fittings with couplings for tank trucks (TW couplings).

Couplings for tank trucks in accordance to this document are intended to link hoses with connections for the transport of liquids, solid matters and gases with the exception of liquid gas and steam. They can be employed in a working pressure range of – 800 mbar up to 25 bar at working temperatures of – 20 °C up to + 65 °C. Couplings for tank trucks for other operating conditions are subject to agreement.

WARNING Male and female dust couplings are pressure resistant plugs. They do not work as locking device, so, if pipelines remain under pressure, a locking device shall be superposed.

2 Normative references

The following referenced documents are indispensable for the application of this document. For dated references, only the edition cited applies. For undated references, the latest edition of the referenced document (including any amendments) applies.

EN 586-2, *Aluminium and aluminium alloys — Forgings — Part 2: Mechanical properties and additional property requirements*

EN 10083-2, *Quenched and tempered steels — Part 2: Technical delivery conditions for unalloyed quality steels*

EN 10088-1, *Stainless steels — Part 1: List of stainless steels*

EN 10213-4, *Technical delivery conditions for steel castings for pressure purposes — Part 4: Austenitic and austenitic-ferritic steel grades*

EN 12420, *Copper and copper alloy — Forgings* [SIST EN 14420-6:2005](#)

EN 14420-1, *Hose fittings with clamp units — Part 1: Requirements, survey, designation and testing*

EN 14420-2, *Hose fittings with clamp units — Part 2: Hose side parts of hose tail*

EN 14420-3, *Hose fittings with clamp units — Part 3: Clamp units, bolted or pinned*

EN 14420-5, *Hose fittings with clamp units — Part 5: Threaded connections*

EN 22768-1, *General tolerances — Part 1: Tolerances for linear and angular dimensions without individual tolerance indications (ISO 2768:1989)*

EN 22768-2, *General tolerances — Part 2: Geometrical tolerances for features without individual tolerance indication (ISO 2768:1989)*

EN ISO 4042, *Fasteners — Electroplated coatings (ISO 4042:1999)*

ISO 48, *Rubber, vulcanized or thermoplastic — Determination of hardness (Hardness between 10 IRHD and 100 IRHD)*

3 Survey

Hose fittings with TW coupling: Female coupling (Type MKS) and male coupling (Type VKS).

Usual fitting combination for the filling of the storage tank: Female coupling (Type MK) and male coupling (Type VK).

Usual fitting combination for closing off the outlet end of the TW: Female coupling (Type MK) and male dust coupling (Type VB).

Usual fitting combination for closing off the filling nozzle or the storage tank: Female dust coupling (Type MB) and male coupling (Type VK).

4 Dimensions, designations

4.1 Hose fittings with TW couplings

4.1.1 General

Dimension in millimetres

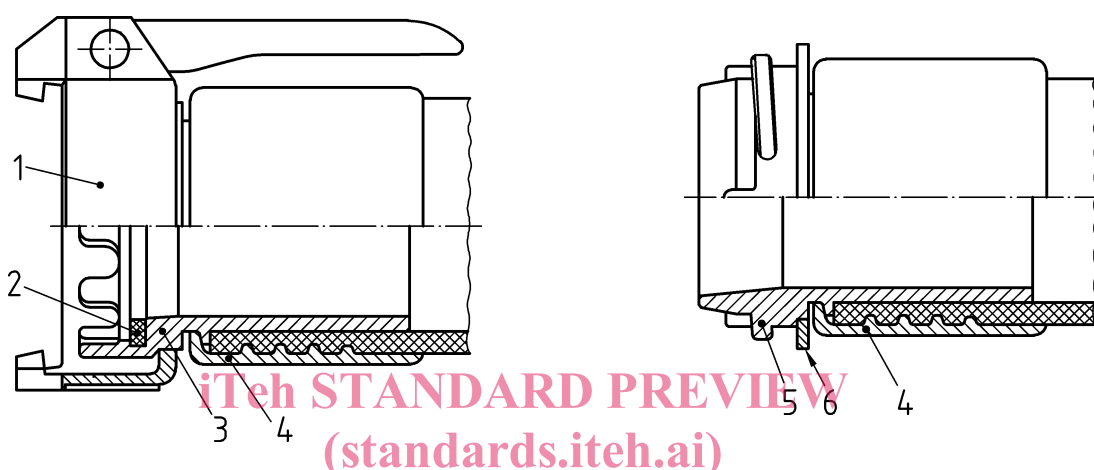

Figure 1 — Hose fitting with TW coupling for female coupling (type MKS)

Figure 2 — Hose fitting with TW coupling for male coupling (type VKS)

<https://standards.iteh.ai/catalog/standards/sist/f7b8f61e-6f34-4df6-b279-0dbb75056b1f/sist-en-14420-6-2005>

Table 1 — Survey

Item No	Designation	Remark
1	Clamping ring with levers	according to 4.3.4.2 and 4.3.4.3
2	Sealing ring	according to 4.3.4.4
3	Hose tail type MKST	according to 4.1.2
4	Clamp unit	according to EN 14420-3
5	Hose tail type VKST	according to 4.1.3
6	Protecting ring	according to 4.1.4

Designation of a complete hose fitting shall be according to EN 14420-1.

EN 14420-6:2004 (E)

4.1.2 Hose tail with female TW coupling

Type MKST

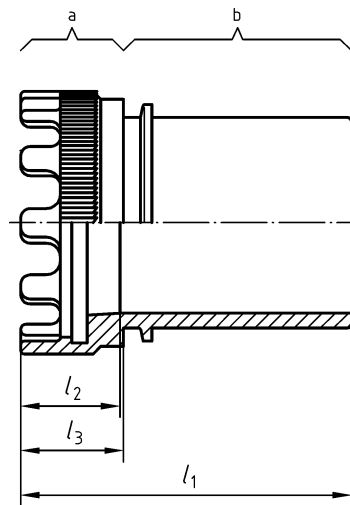

Key

- a Coupling side part of the tail; other dimensions and specifications according to 4.3
 b Hose side part of the tail; dimensions according to EN 14420-2

iTeh STANDARD PREVIEW
Figure 3 — Hose tail type MKST
 (standards.iteh.ai)

Table 2 — Hose tail type MKST

SIST EN 14420-6:2005

<https://standards.iteh.ai/catalog/standards/sist/f7b8f61e-6f34-4df6-b279-0dbb75056b1f/sist-en-14420-6-2005> Dimensions in millimetres

Nominal size DN		For hose internal diameter	l_1 min.	l_2 max.	l_3 +1 0
Connection female TW coupling	Hose connection				
50	40	38	68	24	26
	50	50	75	—	
80	65	63	98	27	35
	80	75	102	35	
100	100	100	125	27	35,5

Example for an ordering designation of a complete hose tail with female TW coupling (type MKST) with nominal size DN 50 on coupling connection side and nominal size DN 40 on hose connecting side, made of copper-zinc alloy (CW614N):

Hose tail EN 14420-6 — MKST — 50 — 40 — CW614N

4.1.3 Hose tail with male TW coupling

Type VKST

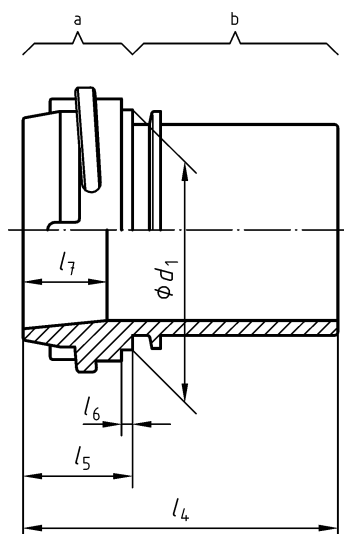

Key

- a Coupling side part of the tail; other dimensions and specifications according to 4.2
 b Hose side part of the tail; dimensions shall be according to EN 14420-2

iteh STANDARD PREVIEW
 (standards.iteh.ai)

Figure 4 — Hose tail type VKST

Table 3 — Hose tail type VKST

<https://standards.iteh.ai/catalog/standards/sist/f7b8f61e-6f34-4df6-b279-0dbb75056b1f/sist-en-14420-6-2005>

Dimensions in millimetres

Nominal size DN		For hose internal diameter	d_1	Tolerances	l_4 min.	l_5 $\pm 0,5$	l_6 min.	l_7 max.
Connection male TW coupling	Hose connection							
50	40	38	45	0 -0,3	80	37,5	2,5	32
	50	50	58		87		3	30
80	65	63	75	+0,8 -0,3	110,5	48	4	40
	80	75	90		115			
100	100	100	113	+1 -0,3	134,5	44,5	4	35

Example for an ordering designation of a complete hose tail with male TW coupling (type VKST) with nominal size DN 80 on coupling connection side and nominal size DN 80 on hose connection side, made of stainless steel (1.4571):

Hose tail EN 14420-6 — VKST — 80 — 80 — 1.4571

EN 14420-6:2004 (E)

4.1.4 Protecting ring

The protecting ring is intended to prevent the external surface of the male couplings from damage, which may be result of hose pipeline handling, e.g. by falling down to earth.

The protecting rings do not have to comply with the drawing, only fixed dimensions shall be used.

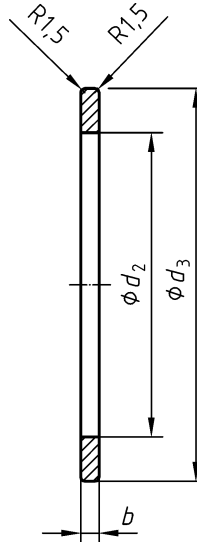

iTeh STANDARD PREVIEW

Figure 5 — Protecting ring

Table 4 — Protecting rings

<https://standards.iteh.ai/catalog/standards/sist/f7b8f61e-6f34-4df6-b279-0dbb75056b1f/sist-en-14420-6-2005> Dimensions in millimetres

Nominal size DN		b	d_2	d_3
Connection male TW coupling	Hose connection	$\pm 0,3$	$+ 0,5$ 0	$\pm 0,5$
50	40	4,5	45,5	90
	50		58,5	
80	65	6	75,5	122
	80		91	
100	100	7	114,5	153

Example for an ordering designation of a protecting ring for a hose tail with nominal size DN 50 of the male coupling connection side and nominal size DN 40 on the hose connection side, made of polyamide (PA):

Protecting ring EN 14420-6 — 50 — 40 — PA

4.2 Male coupling (type VK)

4.2.1 General

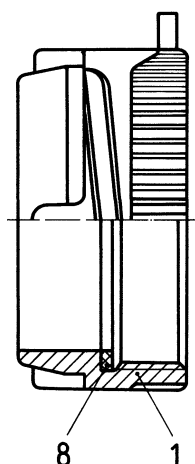

Figure 6 — Male coupling (type VK)

Table 5 — Survey

Pos. No	Number of pieces	Designation
1	1	Body
8	1	Thread sealing ring ^a
^a Dimensions according to EN 14420-5.		

Example for an ordering designation of a complete male coupling (type VK) with nominal size DN 80 and maximum working pressure 25, made of copper-zinc alloy (CW614N):

Coupling EN 14420-6 — VK 80 — 25 — CW614N

For connection with hoses, hose tails according to EN 14420-5 can be screwed into the male coupling (type VK) or one-piece hose fittings in accordance with 4.1 can be used.

EN 14420-6:2004 (E)

4.2.2 Components

4.2.2.1 Body DN 50 and DN 80 (item No 1)

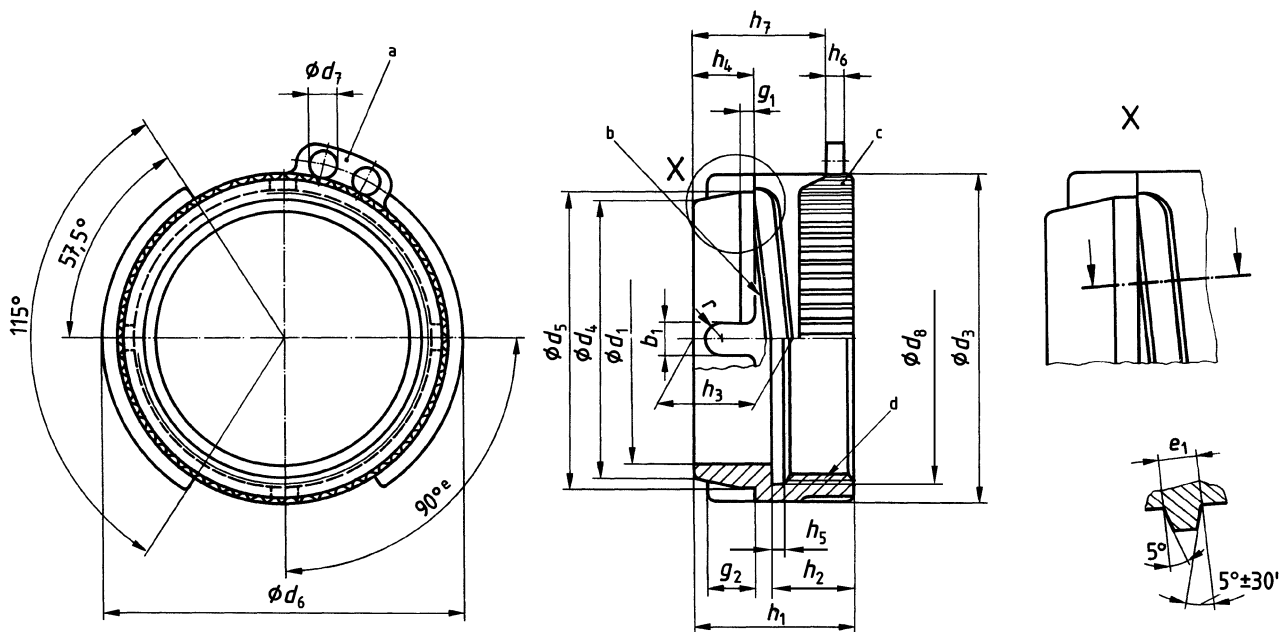

iTeh STANDARD PREVIEW
(standards.iteh.ai)

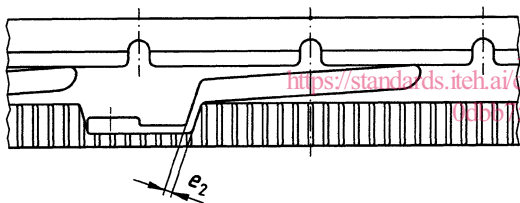

SIST EN 14420-6:2005

[https://standards.iteh.ai/catalog/standards/sist/f7b8f61e-6f34-4df6-b279-](https://standards.iteh.ai/catalog/standards/sist/f7b8f61e-6f34-4df6-b279-013115056b1f/sist-en-14420-6-2005)

[013115056b1f/sist-en-14420-6-2005](https://standards.iteh.ai/catalog/standards/sist/f7b8f61e-6f34-4df6-b279-013115056b1f/sist-en-14420-6-2005)

Key

- a The spatial arrangement do not have to correspond to the drawing
- b Marking
- c Straight knurled portion
- d Thread according to EN 14420-5
- e The angle between cams (90°) shall be checked with a gauge according to Annex A.

Figure 7 — Body DN 50 and DN 80

Table 6 — Dimensions for body DN 50 and DN 80

Dimensions in millimetres

Nominal size DN	b_1	d_1	d_3	d_4	d_5	d_6	d_7	d_8	e_1	e_2	
	$\pm 0,2$		$\pm 0,5$	Tolerances	$\pm 0,4$	$\pm 0,5$		$\pm 0,2$	$\pm 0,6$	$+0,5$ 0	
50	6,5	48	67	55,5	$+0,4$ 0	60	77	8	60,5	7	2,5
80	8,5	76	100	84,5	$\pm 0,5$	90	110	9	88,5	8	3,5

Nominal size DN	g_1	g_2 $+0,5$ 0	h_1 ± 1	h_2 0 $-0,5$	h_3 $\pm 0,2$	h_4 $\pm 0,5$	h_5	h_6 ± 1	h_7 min.	r	Gradient of the curve element
50	4,5	8	39	20	23,5	14,5	3	5	30	3,25	13
80	5	13	48	24	30,5	20	4	5	41	4,25	14

NOTE For DN 50 and DN 80 h_3 should be checked with a gauge according to Annex A.

4.2.2.2 Body DN 100

Dimensions in millimetres

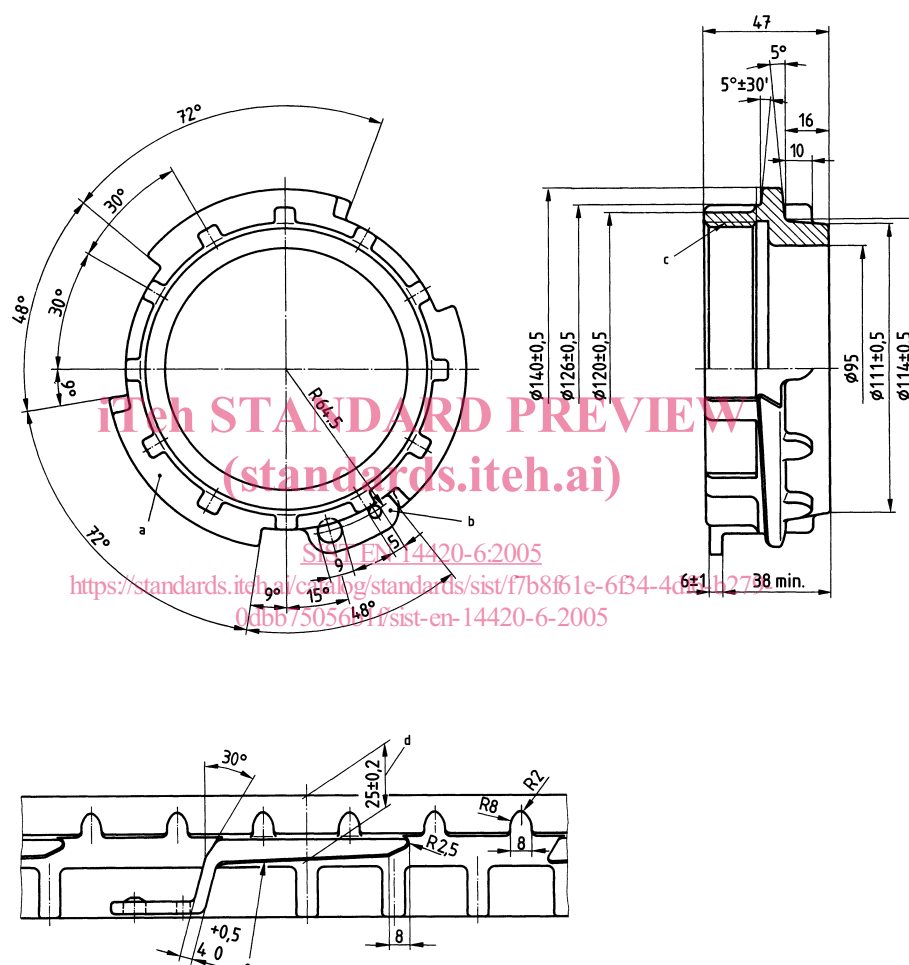

Key

- a Marking
- b The spatial arrangement do not have to correspond to the drawing
- c Thread according to EN 14420-5
- d Gauge dimension under all three curved elements shall be checked with a gauge according to Annex A
- e Gradient 14 mm

Figure 8 — Body DN 100

4.2.2.3 Body designation

Example for an ordering designation of a body item No 1 with nominal size DN 80 for a maximum working pressure of 25 bar, made of copper-zinc alloy (CW614N):

Body EN 14420-6 — 80 — 25 — CW614N