



Designation: **D7635/D7635M – 10 D7635/D7635M – 18**

Standard Test Method for Measurement of Thickness of Coatings Over Fabric Reinforcement¹

This standard is issued under the fixed designation D7635/D7635M; the number immediately following the designation indicates the year of original adoption or, in the case of revision, the year of last revision. A number in parentheses indicates the year of last reapproval. A superscript epsilon (ϵ) indicates an editorial change since the last revision or reapproval.

1. Scope

1.1 This test method covers measuring the thickness of the coating over fiber backing or reinforcing fabric.

1.2 The values stated in either SI units or inch-pound units are to be regarded separately as standard. The values stated in each system may not be exact equivalents; therefore, each system shall be used independently of the other. Combining values from the two systems may result in non-conformance with the standard.

~~1.3 This standard may involve hazardous materials, operations, and equipment. This standard does not purport to address all of the safety concerns, if any, associated with its use. It is the responsibility of the user of this standard to establish appropriate safety and health practices and determine the applicability of regulatory limitations prior to use.~~

1.3 This standard may involve hazardous materials, operations, and equipment. *This standard does not purport to address all of the safety concerns, if any, associated with its use. It is the responsibility of the user of this standard to establish appropriate safety, health, and environmental practices and determine the applicability of regulatory limitations prior to use.*

1.4 *This international standard was developed in accordance with internationally recognized principles on standardization established in the Decision on Principles for the Development of International Standards, Guides and Recommendations issued by the World Trade Organization Technical Barriers to Trade (TBT) Committee.*

2. Referenced Documents

2.1 *ASTM Standards:*²

~~D4434~~[D4434/D4434M](#) Specification for Poly(Vinyl Chloride) Sheet Roofing

[E177](#) Practice for Use of the Terms Precision and Bias in ASTM Test Methods

[E691](#) Practice for Conducting an Interlaboratory Study to Determine the Precision of a Test Method

MEASUREMENT METHOD

3. Principle

3.1 The thickness of coating material over fiber, fabric, or scrim can be measured with a standard or digital optical or reflectance microscope. Measurement is made with a calibrated viewing device.

4. Apparatus

4.1 *Microscope*, 30 to 100 \times magnification capability.

4.1.1 *Light Source*—If the light source on the microscope is not adequate, use a small high-intensity lamp.

4.1.2 *Stage Micrometer*, 25 μm [0.001 in.] divisions.

4.2 *Calibrated Viewing Device*—A digital or analog device designed to provide an enlarged electronic image with calibrations to provide measurements.

5. Calibration Procedure

5.1 Place a standard reflectance stage micrometer or calibrated sample blocks in place of the specimen.

5.2 Turn on the light source.

¹ This test method is under the jurisdiction of ASTM Committee D08 on Roofing and Waterproofing and is the direct responsibility of Subcommittee D08.18 on Nonbituminous Organic Roof Coverings.

Current edition approved June 1, 2010/Nov. 1, 2018, Published July 2010/December 2018. Originally approved in 2010. Last previous edition approved in 2010 as D7635/D7635M – 10. DOI: 10.1520/D7635-D7635M-10-10.1520/D7635-D7635M-18.

² For referenced ASTM standards, visit the ASTM website, www.astm.org, or contact ASTM Customer Service at service@astm.org. For Annual Book of ASTM Standards volume information, refer to the standard's Document Summary page on the ASTM website.

5.3 Position the viewing device (calibrated reticule or camera) such that the scales are superimposed. For electronic imaging, place the calibrated scale marker on the microscope stage. Focus the viewing device on the specimen.

5.4 Calibrate using micrometer or calibrated sample blocks to nearest 10 μm.

5.5 If using digital image for calibration step, record resolution and magnification of calibration image.

6. Specimen Preparation

6.1 Make a clean cut perpendicular to the plane of the specimen, normal to one of the thread yarn intersections, completely through the sheet exposing the area to be measured (see Fig. 1).

6.2 Remove the razor-cut section and mount with the cut surface (analytical plane) facing downward into a sample clip. Secure sample clip in 3.175-cm [1.25-in.] sample cup with cap. Use a piece of double-sided tape to securely attach clip to the cap part of the cup. Record sample orientation and position within cup. Multiclips can be used for mounting multiple samples per mount. Assure all that all samples are oriented normal to the plane of the sample cup cap.

6.3 Mixed long-cure epoxy at a ratio of 6.3 parts resin to one part hardener, per volume. A 3.175-cm [1.25-in.] mount requires 19 ml of epoxy.

6.4 The mounts are allowed to cure for at least 24 h at ambient temperature and humidity.

6.5 After curing (24 hours), polish using the procedure exhibited in Table 1. Clean and dry mounts after each step to insure that all lubricant and polishing compound are removed to prevent contamination in subsequent polishing steps.

7. Specimen Analysis

7.1 During analyses use the same image resolution and magnification used for calibration.

7.2 Observe the cut surface. Measure the thickness of the coating over three of the Machine direction threads-yarns, and three of the cross-machine direction threads-yarns (ignore tie yarn scrim if present) (see Fig. 2 and Fig. 3).

7.3 Average all the results.

7.4 If using electronic imaging technology, save all of the image files generated for archiving.

8. Calculation and Report

8.1 Report the average results from all areas measured as statistically representative of overall film thickness of the film to the nearest 10 μm [0.0005 in.] and the estimated or calculated standard deviation.

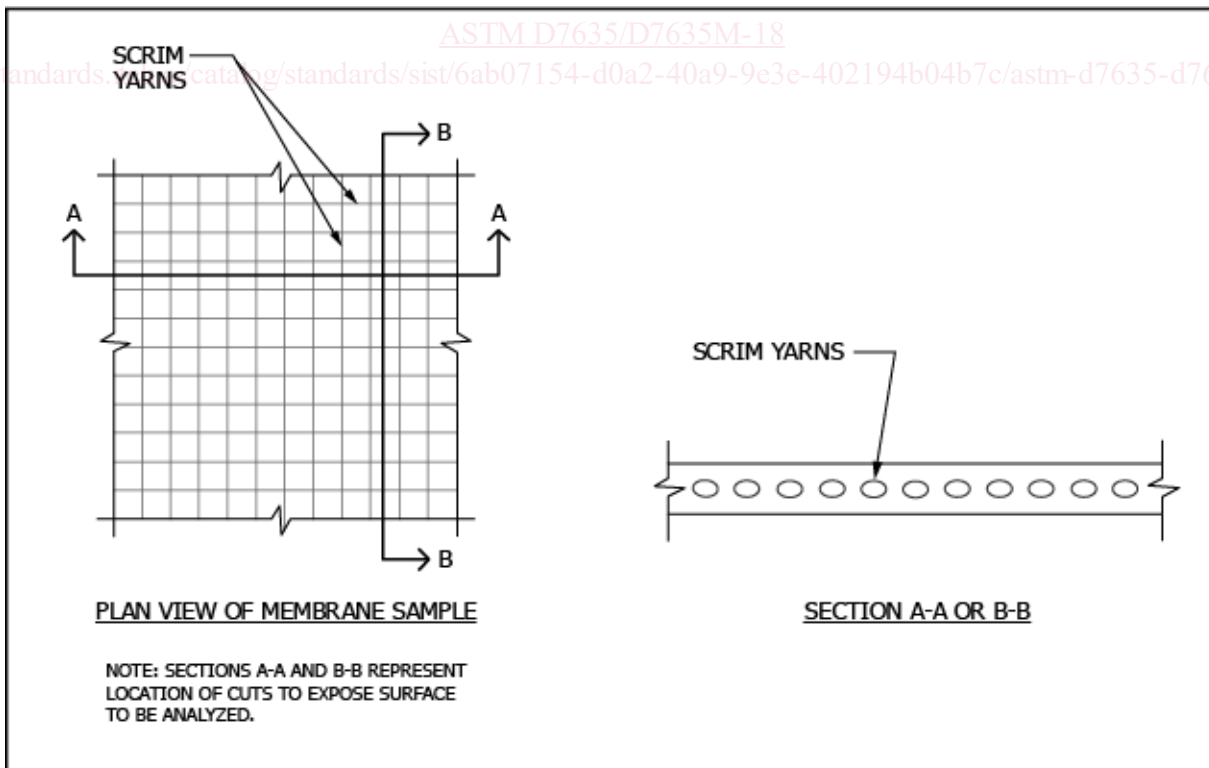

FIG. 1 Schematic of Preparation Illustrating Cuts Normal to Scrim Directions