



Designation: E680 – 79 (Reapproved 2018)

Standard Test Method for Drop Weight Impact Sensitivity of Solid-Phase Hazardous Materials¹

This standard is issued under the fixed designation E680; the number immediately following the designation indicates the year of original adoption or, in the case of revision, the year of last revision. A number in parentheses indicates the year of last reapproval. A superscript epsilon (ϵ) indicates an editorial change since the last revision or reapproval.

INTRODUCTION

This test method is one of several test methods being developed by ASTM Committee E27 on Hazard Potential of Chemicals. This test method is to be used in conjunction with other tests to characterize the hazard potential of chemicals.

1. Scope

1.1 This test method^{2, 3} is designed to determine the relative sensitivities of solid-phase hazardous materials to drop weight impact stimulus. For liquid-phase materials refer to Test Method **D2540**.

1.2 *This standard may involve hazardous materials, operations, and equipment. This standard does not purport to address all of the safety concerns, if any, associated with its use. It is the responsibility of the user of this standard to establish appropriate safety, health, and environmental practices and determine the applicability of regulatory limitations prior to use.*

1.3 *This international standard was developed in accordance with internationally recognized principles on standardization established in the Decision on Principles for the Development of International Standards, Guides and Recommendations issued by the World Trade Organization Technical Barriers to Trade (TBT) Committee.*

2. Referenced Documents

2.1 *ASTM Standards:*⁴

¹ This test method is under the jurisdiction of ASTM Committee E27 on Hazard Potential of Chemicals and is the direct responsibility of Subcommittee E27.02 on Thermal Stability and Condensed Phases.

Current edition approved Nov. 15, 2018. Published December 2018. Originally approved in 1979. Last previous edition approved in 2011 as E680 – 79 (2011) ^{ϵ 1}. DOI: 10.1520/E0680-79R18.

² This test method is a modification of and contains concepts proposed by Hercules, Inc. personnel at Allegheny Ballistics Laboratory. The method was outlined by personnel of Pittsburgh Mining and Safety Research Center, U.S. Bureau of Mines, Pittsburgh, Pa. For additional information see Footnote 3.

³ Smith, D., and Richardson, R. H., "Interpretation of Impact Sensitivity Test Data," *Pyrodynamics*, PYDYA, Vol 6, 1968, pp. 159–178.

⁴ For referenced ASTM standards, visit the ASTM website, www.astm.org, or contact ASTM Customer Service at service@astm.org. For *Annual Book of ASTM Standards* volume information, refer to the standard's Document Summary page on the ASTM website.

D2540 Test Method for Drop-Weight Sensitivity of Liquid Monopropellants (Withdrawn 2003)⁵

3. Summary of Test Method

3.1 Restrictions are placed upon the ranges of impact tool masses and striking surface diameters that may be used, and a standard sample thickness is prescribed for all tests.⁶ In addition, procedures for sample preparation and treatment, as well as procedures for detecting reactions through the use of the human senses, are outlined.

3.2 Drop-weight impact tests are to be performed using the well-known Bruceton up-and-down method.^{7, 8}

3.3 Outlined is a method for normalizing data generated on different impact apparatus.

4. Significance and Use

4.1 This test method does not require an overall rigid standardization of the apparatus. Samples are tested either unconfined or confined in confinement cups. For confined tests, some of the important cup parameters, such as cup material, cup wall thickness, and fit between the cup and the striking pin, are standardized. Data generated from unconfined and confined tests will not, in general, exhibit the same relative scale of

⁵ The last approved version of this historical standard is referenced on www.astm.org.

⁶ Becker, K. R., and Watson, R. W., "A Critique for Drop Weight Impact Testing," Proceedings of the Conference on the Standardization of Safety and Performance Tests for Energetic Materials, Vol 1, September 1977, pp. 415–430. Publication ARLCD-SP-77004, U.S. Army Armament Research and Development Command, Dover, N.J.

⁷ Dixon, W. J., and Massey, F. J. Jr., *Introduction to Statistical Analysis*, McGraw-Hill Book Co., Inc., 1957, pp. 319–327.

⁸ Statistical Research Group, Princeton University, "Statistical Analysis for a New Procedure in Sensitivity Experiments," AMP Report No. 101.1R, SRG-P, No. 40, Submitted to Applied Mathematics Panel, National Defense Research Committee, July 1944, p. 58.

sensitivities, and must be identified as confined or unconfined data and compared separately.

4.2 This test method applies to all testing where the intent is to establish a relative sensitivity scale for hazardous materials. It is not intended to prohibit testing process-thickness samples nor prohibit the use of other than standard tool masses and striking diameters to generate data for special purposes or for in-house comparisons. In addition, the test method is not intended to restrict the generation of results at other than the H_{50} point as may be desirable for hazard analysis techniques.

4.3 The normalized data will serve as a measure of the relative sensitivities of hazardous materials at the 50 % probability of reaction level. The normalized H_{50} values can also be used in conjunction with additional data relating to other probability of reaction levels (not a part of this test method) to assess hazards associated with the manufacture, transportation, storage, and use of hazardous materials.

5. Definitions

5.1 H_{50} value—a drop height with a 50 % probability of reaction, as determined experimentally by the Bruceton up-and-down method.

5.2 *impact tools*—the drop weight, intermediate weight, and anvil.

5.3 *drop weight*—that weight which is raised to a selected height and released. This weight does not impact the sample directly; rather it strikes another stationary weight that is in contact with the sample.

5.4 *intermediate weight*—the stationary weight in contact with the sample.

5.5 *anvil*—the smooth, hardened surface upon which the test sample or cup containing the sample rests.

5.6 *unconfined test*—a test in which the test sample is placed directly upon the anvil with no lateral confinement.

5.7 *confined test*—a test in which the test sample is contained within a confinement cup (sample container), and the confinement cup is then placed upon the anvil.

5.8 *confinement cup*—the metal sample container used in confined tests.

5.9 *guide bushing*—the steel bushing that surrounds, aligns, and holds the stationary intermediate weight in place.

5.10 *guide system*—the rails, wires, and shaft that guide the drop weight during its fall.

5.11 *striking surface*—the hardened, smooth, circular bottom surface of the intermediate tool that is in contact with the test sample.

5.12 *impact apparatus or machine*—the total apparatus including the foundation parts, guide rails, electromagnet lift, winch, and tools.

6. Apparatus

6.1 A complete impact apparatus is the specialized apparatus necessary for this test method.

6.2 The masses of the drop weight (m_1) and intermediate weight (m_2) should, preferably, be equal. However, the intermediate weight mass may be less than that of the drop weight mass so long as the mass ratio m_2/m_1 is 0.6 or greater. This ensures that the force-time stimulus a test sample is subjected to will be nonoscillatory in nature, and ensures that the transfer of energy from the drop weight to the intermediate weight does not vary significantly.

6.3 The mass of the drop weight should be between 1.0 to 3.5 kg.

6.4 The hardness of all tooling surfaces involved in the impact (drop weight, intermediate weight, and anvil) should have a Rockwell C Hardness of 55 to 59 HRC.

6.5 The diameter of the striking surface of the intermediate weight shall be 9.52 to 19.05 mm ($3/8$ to $3/4$ in.). These limits were determined simply on the basis that data have been successfully normalized for tool diameters in this range.

6.6 The finish on the striking surface of the intermediate weight and of the anvil, though not highly critical in tests with solid explosives, should be a No. 8 grind (8 μ n.) or finer. If substantially different surface finishes are used, the data obtained should be accompanied by a footnote specifying the finish used.

6.7 In confined tests, the confinement cup shall be fabricated from Type 302 stainless steel. The cup base thickness shall range from 0.13 to 0.15 mm (0.005 to 0.006 in.). The outer periphery of the striking pin shall be in contact with a small portion of the arc joining the side and bottom of the cup. Although this permits greater energy losses in working the metal inside the cup than if the whole striking surface engaged only the flat portion of the metal in the base of the cup, it does ensure better confinement with less flow of test material up the sides of the striking pin and cup. A typical confinement cup is shown in Fig. 1. This, together with the striking pin dimensions shown in Fig. 2, provide some insight on a suitable mating between the striking pin and cup.

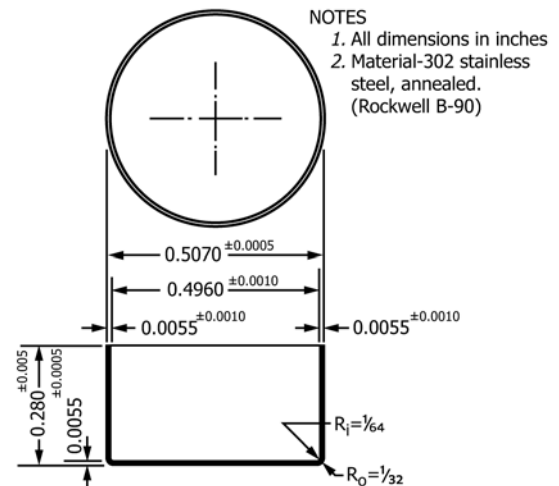

FIG. 1 Confinement Cup Used as a Sample Container in Confined Tests

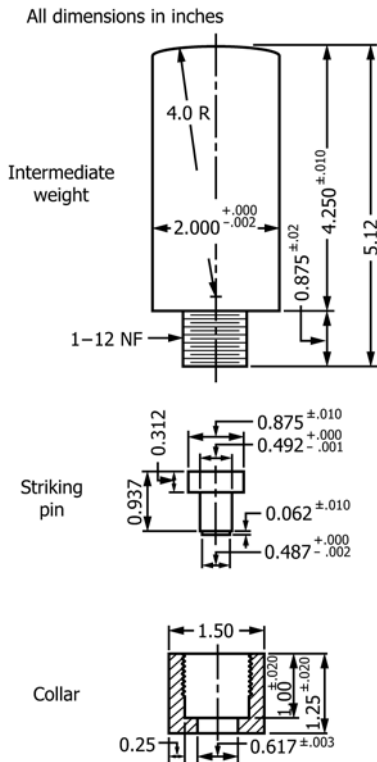

FIG. 2 Intermediate Weight Assembly

6.8 Experience has shown that an appreciable difference in the behavior of the apparatus can result from the manner in which it is mounted. Thus, the machine should be mounted on, and firmly attached to, a solid concrete foundation, preferably anchored to the foundation of a building (see Test Method D2540).

6.9 Fig. 3 illustrates a typical impact apparatus, and Figs. 4 and 1 are detailed drawings of a drop weight, an intermediate weight, and a confinement cup. Helpful notes on construction of the tools are found in Appendix X1. These tools and apparatus are in use at the U.S. Bureau of Mines, Bruceton, Pa., but are not necessarily the only acceptable designs. All designs, however, should incorporate a device that captures the drop weight after it rebounds to prevent further interactions with the intermediate weight.

7. Test Sample

7.1 Sample thickness must be the same for all tests. This is achieved by using a constant volume per unit area sample spread uniformly over that area. The standard is 31.5 mm³/cm². This provides a distributed thickness of 0.315 mm (12.4 mils) and ensures the same energy input per unit mass of a given test material no matter what the diameter of the striking surface area is. Thus, for a sample diameter of 12.7 mm (0.50 in.), 40 mm³ of sample volume would be used. Proportionately larger or smaller sample volumes, varying in direct proportion to the sample, may be used so long as the sample volume per unit area is 31.5 mm³/cm². Errors in sample volume may be ±10 %, and sample measuring spoons having the appropriate volume can be machined or drilled for this purpose. In cases where it is desirable to test process thickness samples that

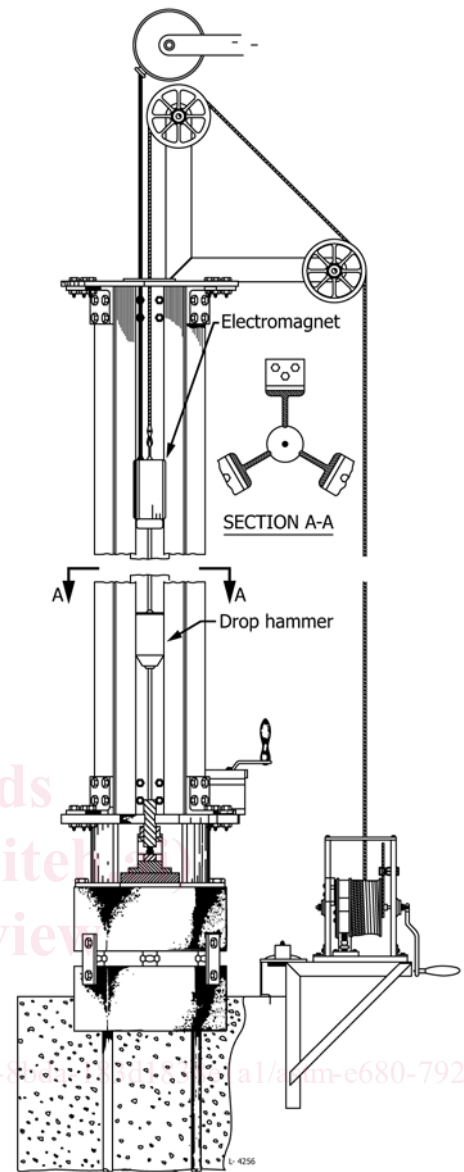

FIG. 3 U.S. Bureau of Mines Impact Apparatus

differ from the standard, simply indicate the thickness used, especially if the H_{50} values appear in the same tables together with H_{50} values obtained using standard thickness samples.

7.1.1 In some cases, the sample consistency may prohibit the sample from being measured in a measuring spoon. In these instances, the proper sample size can be determined by its mass; $M = \rho V$, where V is the proper volume for a given sample area, and ρ is the loose-packing density of the sample. The density may have to be determined if it has not been specified.

7.2 Specifications of sample diameters to be used in conjunction with different diameter tools are as follows: (1) in confined tests, specifically, a test where the sample is confined in a cylindrical cup, the sample diameter will be the same as the inside diameter of the cup. Hence, calculate a sample volume or mass based upon the inside diameter of the confinement cup, and (2) for unconfined tests, specifically, a

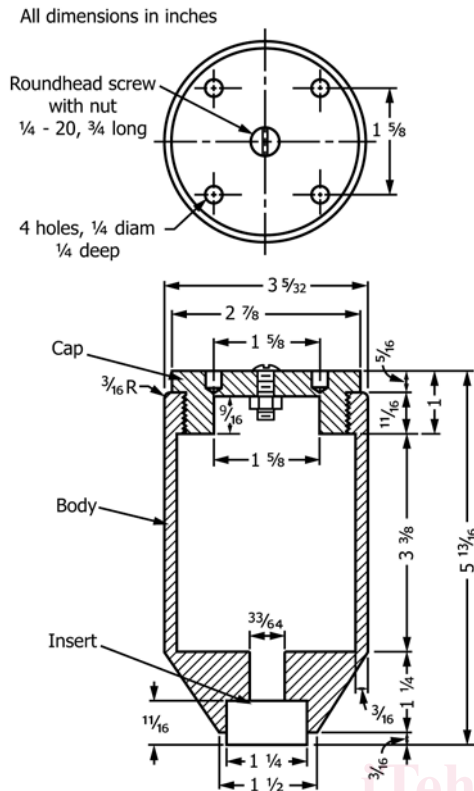

FIG. 4 Drop Weight Assembly

test where the sample is spread directly upon the anvil, use about a 0.33-mm (13-mil) thick template made from plastic, metal, or tape having a circular hole cut in it. Place the template on the anvil, pile the sample in the hole, and scrape level with a spatula or straight edge. The hole diameter should, in all cases, be somewhat larger than the tool contact surface diameter. Leave the template in place during the impact trial. The larger size will make it easy to miss striking the periphery of the template hole during impact. The template also serves as an excellent means for keeping the sample inbounds. The recommended template hole for a 12.7-mm (1/2-in.) diameter tool is 15.9 mm (5/8 in.), but it may be 19.1 mm (3/4 in.) or larger, as long as a proportionally larger sample is used. Here, it is important to remember that the sample volume or mass used to obtain constant-thickness samples is based upon the template diameter, not the tool diameter.

7.2.1 In no case should the sample diameter be less than that of the tool. The normalization method cannot be applied if this is the case. Furthermore, the normalization method cannot be applied to mixed data from confined and unconfined tests. It is generally applicable in the unconfined case. Information is limited on applicability to the confined case. However, it is believed that data from confined trials could be normalized provided the confinement parameters are reasonably alike. The important cup parameters that were standardized were given in 6.7.

8. Preparation of Apparatus

8.1 Inspection checks of the apparatus are an important part of the test procedure. This includes the physical condition of certain parts, alignment, and cleanliness.

8.1.1 *Physical Condition of Equipment*—Inspect the guide rails, or wires, or shafts periodically for evidence of nicks, frays, dirt, or other physical impairments, and eliminate any defects that might impede the drop weight in its fall. Inspect the drop weight, intermediate weight, and anvil, making especially sure that all metal surfaces that are involved in the collision process are free from defects. Make sure that the intermediate weight slides through and rotates freely in the guide bushing without significant side play. Recondition or replace the bottom surface (striking surface) of the intermediate weight or top surface of the anvil if they show any evidence of wear. Use a new, clean confinement cup each trial in confined tests if confinement cups (sample containers) are used.

8.1.2 *Alignment*—Align the guide system, allowing the drop weight to fall along a path perpendicular to the plane of the earth within ± 0.25 deg. Misalignments of this magnitude can easily be detected using a plumb line, since a 0.25-deg misalignment amounts to a 13-mm displacement over a 3000-mm length.

8.1.2.1 Align the bottom face (striking surface) of the intermediate weight and the top surface of the anvil. These surfaces must be both plane and parallel. A convenient way to check this is with Prussian blue dye. Place a small amount of the dye on a piece of paper and insert the paper between the intermediate tool striking surface and anvil. By hand lower the intermediate tool onto the area of the paper containing the dye. Lift the intermediate tool and insert a clean piece of paper. Lower and raise the tool a number of times on different areas of the clean paper, making many different imprints. Be careful not to make a judgment solely on the basis of the first or second imprint, since an excess of dye might smear and cover up defects. If the two surfaces are not parallel, a portion of one side of the circle will be missing. A convex tool striking surface will produce a circle having a diameter less than that of the tool striking surface, whereas a concave tool will produce a normal diameter circle with the bare spot centrally located. If any of these defects or others are noted, take proper steps to eliminate them.

8.1.3 *Cleanliness*—Keep all surfaces of the weights, guides, and interior of the guide bushing reasonably clean at all times. Clean especially the intermediate tool striking surface and top of the anvil for each trial. All traces of explosive or residue from reactions must be removed with a tissue wet with acetone, and then wiped with clean, dry tissue. Clean the bottom surface of the drop weight and top surface of the intermediate weight several times during an up-and-down test.

9. Procedures

9.1 Avoid testing hygroscopic materials under high humidity conditions, if climate control is not available. Sample conditioning and certain test procedures can be implemented to minimize humidity effects.

9.2 For materials that have been stored under unknown or high humidity conditions, vacuum dry the samples for 2 h at 90°C. For test samples thermally sensitive to 90°C vacuum dry for 8 h at 50°C.