



Designation: **C1716/C1716M – 18** C1716/C1716M – 18a

Standard Specification for Compression Testing Machine Requirements for Concrete Masonry Units, Related Units, and Prisms¹

This standard is issued under the fixed designation C1716/C1716M; the number immediately following the designation indicates the year of original adoption or, in the case of revision, the year of last revision. A number in parentheses indicates the year of last reapproval. A superscript epsilon (ϵ) indicates an editorial change since the last revision or reapproval.

1. Scope*

1.1 This specification provides minimum design standards for testing machines used to measure the compressive strength of concrete masonry units, related units, and masonry prisms covered under Test Methods **C140/C140M** and **C1314**.

1.2 The text of this standard references notes and footnotes which provide explanatory material. These notes and footnotes (excluding those in tables and figures) shall not be considered as requirements of this standard.

1.3 This specification shall be used to determine the maximum allowable specimen size and the maximum allowable load limits on a specific specimen for any test machine. These limits are based on deflection of the bearing surfaces and the machine load frame. These limits may not reflect the actual capacity of the machine and do not supersede the machine manufacturer's recommended operational limits. The user must determine if testing machine capacities, allowable specimen size and maximum allowable load are appropriate for the sample to be tested.

1.4 The values stated in either SI units or inch-pound units are to be regarded separately as standard. The values stated in each system may not be exact equivalents; therefore, each system shall be used independently of the other. Combining values from the two systems may result in non-conformance with the standard.

1.5 *This standard does not purport to address all of the safety concerns, if any, associated with its use. It is the responsibility of the user of this standard to establish appropriate safety, health, and environmental practices and determine the applicability of regulatory limitations prior to use.*

1.6 *This international standard was developed in accordance with internationally recognized principles on standardization established in the Decision on Principles for the Development of International Standards, Guides and Recommendations issued by the World Trade Organization Technical Barriers to Trade (TBT) Committee.*

2. Referenced Documents

2.1 ASTM Standards:²

C140/C140M Test Methods for Sampling and Testing Concrete Masonry Units and Related Units

C1093 Practice for Accreditation of Testing Agencies for Masonry

C1232 Terminology for Masonry

C1314 Test Method for Compressive Strength of Masonry Prisms

E4 Practices for Force Verification of Testing Machines

3. Terminology

3.1 Definitions:

3.1.1 For definitions of terms used in this specification, refer to Terminology **C1232**.

3.2 Definitions: Definitions of Terms Specific to This Standard:

3.2.1 *bearing, adj*—direct contact with the specimen being tested, as in bearing plate, bearing block, and bearing platen.

3.2.2 *block, n*—steel piece 50 mm [2 in.] thick or greater that provides additional load capacity in bending to platens.

¹ This specification is under the jurisdiction of ASTM Committee **C15** on Manufactured Masonry Units and is the direct responsibility of Subcommittee **C15.04** on Research.

Current edition approved ~~June 1, 2018~~ Dec. 1, 2018. Published ~~July 2018~~ December 2018. Originally approved in 2010. Last previous edition approved in ~~2016~~ 2018 as ~~C1716/C1716M – 16~~ C1716/C1716M – 18. DOI: ~~10.1520/C1716-C1716M-18~~ 10.1520/C1716_C1716M-18A.

² For referenced ASTM standards, visit the ASTM website, www.astm.org, or contact ASTM Customer Service at service@astm.org. For *Annual Book of ASTM Standards* volume information, refer to the standard's Document Summary page on the ASTM website.

*A Summary of Changes section appears at the end of this standard

3.2.2.1 Discussion—

Blocks may be used to accommodate testing specimens of various heights in a testing machine.

3.2.3 *composite, adj*—made up of two or more pieces or materials.

3.2.4 *load frame, n*—all components of the testing machine that react against forces applied to the test specimen during testing.

3.2.5 *plate, n*—steel piece less than 50 mm [2 in.] thick.

3.2.5.1 Discussion—

Plates are used to accommodate test specimens of various heights in a testing machine but do not provide additional load capacity in bending to platens or blocks. Plates can also be used as bearing surfaces.

3.2.6 *platen, n*—the primary bearing surfaces of the testing machine.

3.2.6.1 Discussion—

Platen is a general term without specific properties implied. In general, the lower platen is semi-permanently fixed to the testing machine and the upper platen is semi-permanently fixed to a hemispherical thrust bearing.

3.2.7 *spacer, n*—plates, blocks, or equipment and fixtures specific to a testing machine, used to adjust the position of bearing surfaces to accommodate test specimens.

NOTE 1—Plates, blocks or platens used in bearing must be hardened. Spacers do not have to be hardened. Blocks are structural while plates are not.

4. Testing Machine Requirements

4.1 Machine Loading Requirements:

4.1.1 The testing machine must be power operated and apply the load continuously, rather than intermittently, and without shock.

4.1.2 The machine must be capable of maintaining specific loading rates required by the test. Variations in the loading rate over the elastic portion of the test shall not exceed $\pm 20\%$ of the set loading rate.

4.1.3 The testing machine must be capable of a minimum of 50 mm [2 in.] of continuous travel or displacement to accommodate positioning and testing of a specimen.

4.2 *Gauges and Displays*—Gauges and displays indicating loads shall meet the requirements of Practices E4, except in no case shall the verified force range include forces less than 100 times the resolution of the force indicator.

4.3 *Accuracy*—The accuracy and calibration of the testing machine shall meet the requirements of Practices E4. Prior to testing, calibration is required:

4.3.1 At the frequency prescribed in Practice C1093,

4.3.2 On original installation or after relocation,

4.3.3 Whenever there is reason to suspect the accuracy of the indicated loads, or

4.3.4 After making repairs or adjustments that affect the operation of the force applying system or the values displayed on the load indicating system, except for zero adjustments that compensate for the mass of bearing blocks or specimen, or both.

4.4 Load Frame:

4.4.1 Load frames shall have a minimum lateral stiffness of 18×10^6 N/m [10×10^4 lb/in.], and a longitudinal stiffness of 18×10^8 N/m [10×10^6 lb/in.].

4.4.2 Differential longitudinal strain of the load frame due to an eccentric loading shall be limited to 0.0001 mm/mm [0.0001 in./in.] at the maximum capacity of the machine or the rated capacity of the specific test setup. Eccentricity of the load shall be considered as 5 % of the maximum width of the specimen. See Appendix X1 for a discussion on allowable longitudinal strain and machine capacity.

NOTE 2—In testing machines with significant differences in lateral stiffness, the center of mass and center of effort shall lie on the axis perpendicular to the axis of maximum lateral stiffness (see Fig. X1.1). Test specimen centroid of compressive strength may not coincide with its centroid of mass. Test specimen section aspect ratio affects measured compressive strength but not mass.

4.4.3 If the design of the load frame makes it an integral part of the support against deflection for platens, blocks, or testing heads, the specific parts of the load frame supporting platens, blocks, or testing heads shall meet the requirements of 4.9 for flatness, finish, and materials.

4.4.4 Testing machines with fixed geometry frames and adjustable geometry frames are permitted.

4.5 Plates, Blocks, and Platens:

4.5.1 Plates, blocks, and platens shall meet requirements of 4.9 for flatness and surface finish. Surface treatments or plating to reduce corrosion is permitted.

4.5.2 *Spacer-Plate*—A one piece steel plate, less than 50 mm [2 in.] in thickness and greater than 11.5 mm [0.45 in.] in thickness. ~~Spacer plates shall not be used in direct contact with the test specimen. Spacer plates~~ Plates provide no additional load capacity in bending to platens or blocks.

4.5.3 *Bearing Plate*—A one piece hardened steel plate, less than 50 mm [2 in.] in thickness and greater than 11.5 mm [0.45 in.] in thickness. Bearing plates provide a bearing surface in direct contact with a test specimen. Bearing plates provide no additional load capacity in bending to platens or blocks.

4.5.4 *Spacer-Block*—A one piece steel plate, 50 mm [2 in.] in thickness or greater. ~~Spacer blocks shall not be used in direct contact with the test specimen.~~

4.5.5 *Bearing Block*—A one piece hardened steel plate, 50 mm [2 in.] in thickness or greater, that provides a bearing surface in direct contact with a test specimen. Bearing blocks provide additional load capacity in bending to platens or blocks.

4.5.4 *Platen*—A one piece steel plate, at least 25 mm [1 in.] thick when new and at least 22 mm [0.9 in.] thick when in service. ~~Platens may be unhardened if they are not used for bearing.~~

NOTE 3—Platens 50 mm [2 in.] thick or greater act as blocks and bearing capacities in bending are calculated accordingly.

4.6 Spacers:

4.6.1 Spacers and bearing plates are permitted. Plates, blocks, and spacers are used to adjust the position of bearing surfaces to accommodate test specimens.

NOTE 4—Plates and blocks are usually placed between the upper and lower platens to accommodate specimen size while spacers are usually placed between testing heads and the frame of the testing machine.

4.6.2 Spacers excluding those provided by the testing machine manufacturer must be constructed of steel.

4.6.3 Non-ferrous and composite spacers, provided by the testing machine manufacturer, used between the upper testing head and the lower platen shall have their load capacity clearly indicated on the spacer and shall be used with a block or bearing block between the spacer and the test specimen.

NOTE 5—The block may be integral to the design of a composite spacer.

4.6.4 Spacers placed between the lower platen and lower bearing block must be a minimum of 6 mm [0.25 in.] wider and 6 mm [0.25 in.] longer than the effective bearing area of the lower platen required for the test, or the length and width of the platen, whichever is smaller.

4.6.5 Spacers used between the upper and lower platen must meet all requirements of 4.9 for flatness and surface finish.

4.7 Hemispherical Head Design:

4.7.1 The upper platen or bearing surface of the testing machine shall be supported with a hemispherical thrust bearing to allow small angular movement of the bearing surface.

NOTE 6—The preferred design includes a socket and ball hemispherical section semi-permanently or permanently attached to a single bearing block or platen.

4.7.2 The ball and the socket shall be designed so that the steel in the contact area of the hemispherical bearing does not permanently deform when loaded to the capacity of the testing machine or the rated load of the testing head.

4.7.3 The curved surfaces of the hemispherical bearing surface shall be kept clean and shall be lubricated with petroleum-type oil such as conventional motor oil and not with grease.

NOTE 7—After contacting the specimen and application of small initial load, further tilting of the spherically seated block is neither intended nor desirable. Spherical bearing blocks that rotate under load may reduce measured strengths.

4.7.4 The upper bearing surface and its attachment to the spherical seat shall be such that the bearing face can be rotated freely at least 2° in any direction perpendicular to the axis of loading.

4.7.5 Close contact of the hemispherical bearing surfaces is preferred. Testing head designs with the surfaces not held in close contact at all times shall have suitable alignment fixtures to assure the hemispherical bearing surfaces contact with lateral motion less than 0.75 mm [0.03 in.].

4.7.6 The radius of the hemispherical bearing shall not extend beyond the bearing face of the upper platen or bearing block.

4.7.7 Hemispherical bearings utilizing non-integral construction shall be designed to withstand lateral loads up to 7 % of the maximum rated capacity of the testing head. Non-integral construction for hemispherical bearings are those bearing heads with the convex hemispherical bearing section mechanically connected to the bearing block or upper platen, rather than those machined from a single piece of steel.

4.7.8 If any portion of the upper platen is less than 50 mm [2 in.] thick, that portion shall be considered a spacer for calculations of deflection under load. In a hemispherical head utilizing non-integral construction, the hemispherical bearing portion shall be exempt from this requirement.

4.7.9 The bearing surface shall be designed to meet the requirements of 4.10 for deflection under load.

4.8 Lower Platen Design:

4.8.1 If the lower platen is the primary bearing surface, the bearing surface shall be designed to meet the requirements of 4.10 for deflection under load.

4.8.2 If any portion of the lower platen is less than 50 mm [2 in.] thick, it shall be considered a spacer for calculations of deflection under load.

4.9 *Prescriptive Design Requirements for Blocks and Platens:*

4.9.1 The working surfaces of blocks, plates and platens shall be finished to better than RMS (root mean square) 63. Bearing surfaces shall be finished to RMS 30 or better. Top and bottom surfaces must be parallel within ± 0.0005 mm/mm [0.0005 in./in.] on plates less than 50 mm [2 in.] thick and ± 0.0010 mm/mm [0.0010 in./in.] on platens and blocks 50 mm [2 in.] or greater in thickness.

4.9.2 The length and width of bearing blocks, plates, and platens shall be a minimum of 6 mm [0.25 in.] larger than the length and width of the test specimen, respectively.

4.9.3 Any surface within 1.2 mm [0.05 in.] of an edge is exempt from finish and flatness requirements.

4.9.4 Side surfaces not intended for loading are excluded from finish requirements.

4.9.5 Surfaces shall be flat within ± 0.0125 mm in 150 mm [0.0005 in. in 6 in.]. In addition, the entire surface excluding the edges must be flat within ± 0.025 mm [0.001 in.]. If a bearing surface is rated to a maximum specimen size, the flatness tolerance applies to the rated working area and the rated size must be clearly indicated on the front of the plate, block, or platen. The rated working area shall meet the requirements of 4.9.2.

NOTE 8—Compliance with flatness tolerances can be determined using a suitable straight edge and feeler gauge. A 0.025-mm [0.001-in.] feeler gage should be a no-go gage under a 150-mm [6-in.] straight edge on any portion of the working area. A 0.075-mm [0.003-in.] feeler gauge should be a no-go gauge under a straight edge spanning any portion of the rated working area. The 0.075-mm [0.003-in.] feeler gauge is slightly oversized to allow for the accuracy of straight edges over 300 mm [12 in.] in length. Other suitable methods may be used.

4.9.6 All surfaces used in bearing must be hardened to a minimum of 55 HRC (HB 560). Surface treatments such as plating shall not be used to comply with the surface hardness requirements. Plates and blocks with one bearing surface shall have that surface clearly indicated with permanent markings.

NOTE 9—It is preferred that bearing plates and bearing blocks have all working surfaces hardened. It is recommended that bearing surfaces be hardened to a depth of 1.5 mm [0.06 in.] to allow for resurfacing of the bearing face.

4.9.7 Permanent markings designed to aid in positioning of specimen and spacers or to indicate rated size that are machined shall not exceed 0.75 mm [0.03 in.] wide by 1.0 mm [0.04 in.] deep. Permanent markings that are etched shall not exceed 2.5 mm [0.1 in.] wide by 0.005 mm [0.0002 in.] deep.

NOTE 10—Markings are allowed, but not required by this standard. Studies have shown that machined markings can affect the results of high strength specimens.

4.9.8 Surfaces with individual scratches larger than 0.25 mm [0.010 in.] wide by 50 mm [2 in.] long, and individual dents with area exceeding 30 mm² [0.05 in²] (approximately 6 mm [0.25 in.] in diameter), and depth exceeding 0.12 mm [0.005 in.] shall not be used as bearing surfaces. Scratches and dents outside the bearing area of 4.9.2 are excluded.

NOTE 11—Bearing surfaces with several scratches and or dents shall be replaced or resurfaced. Best engineering practice must be used to access the number, location and significance of imperfections to the bearing surface.

4.9.8.1 Plates and blocks with dents and scratches exceeding those permitted by 4.9.8 may be used as spacers providing they meet all other requirements of 4.9.5.

4.9.9 Holes and features required for fixtures or as part of the testing head design must have a minimum depth of cover to the bearing surface of twice the diameter of the hole.

4.10 *Prescriptive Design for Deflection under Load:*

4.10.1 The purpose of this section is to minimize the allowable deflections of platens and blocks under load. Deflection of the bearing surfaces reduces the measured compressive strength of a test specimen. Use of spacers, plates and blocks, between the test specimen and the testing head are allowed but may pose a safety concern if supported only by the test specimen.

4.10.2 Machine platens not large enough to test the specimen shall be used in conjunction with a block to increase the effective bearing area. The requirements for block thickness must be achieved with a single block.

NOTE 12—The preferred design is to use single platen or bearing block large enough to test the intended specimen.

4.10.3 Bearing block design for specimen loadings up to 35 MPa [5000 psi]:

4.10.3.1 The maximum bearing width of platens 50 mm [2 in.] thick or greater and of blocks which extend beyond the maximum support width at their base, shall be the maximum support width at their base plus twice their thickness. When the bearing area of the upper platen or lower platen is not sufficient to cover the area of the specimen, a single steel block with a minimum thickness equal to the distance from the maximum support width at its base to the most distant corner of the specimen shall be placed between the platen and the specimen.

4.10.3.2 The maximum support width of a platen or bearing block is determined by the maximum diameter of a 53.1° cone (2:1 rise over run) with its base circumscribed on the bearing face of the platen that will remain within solid support (platen, frame,

hemispherical head and socket, spacers between the platen and frame, or solid rams). Spacers placed between the platens and bearing blocks shall be ignored. **Figs. A1.3-A1.5** in **Annex A1** show the projection lines used to determine the maximum support width and the maximum bearing width.

NOTE 13—The bearing block or platen in contact with the test specimen may cantilever beyond its support at a 1:1 ratio. Support of this block or platen must be at a minimum of 2:1, twice as thick as any cantilevered sections.

4.10.4 Bearing block design for specimen loadings over 35 MPa [5000 psi]:

4.10.4.1 The maximum bearing width of the platen equals its maximum support width. If an additional bearing block is used it shall have a thickness equal to at least the twice the distance from the maximum support width of the platen to the most distant corner of the specimen.

5. Keywords

5.1 bearing block; bearing surface; load frame; platen; spacer; testing machine

ANNEX

(Mandatory Information)

A1. DETERMINING USABLE BEARING AND SUPPORT AREA OF PLATENS AND BEARING BLOCKS

A1.1 This annex provides mathematical and graphical solutions for determining the usable bearing and support area of platens and bearing blocks. The results of either solution will provide a machine design compliant with the requirements of **4.10** of this standard. Generally, the graphical solution is more complicated and more exact, while the mathematical solution is less complicated but also conservative. It is not necessary to comply with both solutions. See **Note A1.1**.

NOTE A1.1—Most users of this standard may want to start with determining compliance with the requirements for a machine using the mathematical solution as it is easier to apply. It is more conservative than the graphical solution, so it may be possible that, in borderline cases, a machine that would not comply with the mathematical solution might comply with the graphical solution. Since it is only required to comply with one solution, a machine meeting the graphical solution but not the mathematical solution is still acceptable.

MATHEMATICAL SOLUTION

A1.2 Mathematical Solution

A1.2.1 This section provides the details for determining the usable bearing and support area of platens and bearing blocks using the mathematical method. This method is less complicated than the graphical solution, but more conservative. Nevertheless, the mathematical solution will provide acceptable solutions in most cases (see **Note A1.1**). The graphical solution for determination of these properties can be found in **A1.3**.

A1.2.1.1 In all of the mathematical solutions, the maximum support width, MSW, defines the maximum area used for specimens with strengths greater than 35 MPa [5000 psi]. Likewise, the maximum bearing width, MBW, defines the maximum area used for specimens with strengths less than or equal to 35 MPa [5000 psi]. For any given testing machine, the effective MSW and MBW is the smaller of the values calculated for the upper and lower platens.

A1.2.1.2 If the effective MSW or MBW is not sufficient to test a particular specimen, a single bearing block of at least 50 mm [2 in.] in thickness can be added underneath the upper platen or above the bottom platen or both. If a bearing block is used, it becomes an extension of the platen and is accounted for in the calculations as detailed in **A1.2.2** and **A1.2.3**. The bearing block can have a thickness greater than 50 mm [2 in.] if additional thickness is needed to achieve the required MSW or MBW.

A1.2.1.3 If any spacers are used in the testing configuration, they are ignored in the calculation of MSW and MBW since they are assumed to provide no additional load carrying capacity. Spacers cannot be used in contact with the test specimen.

A1.2.2 *Upper Platen*—The maximum bearing dimensions of the upper platen, MBW_{UP} and MSW_{UP} , shall be calculated as follows (See Fig. A1.1):

For specimen strengths up to 35 MPa [5000 psi]:

$$MBW_{UP}, \text{ mm [in.]} = D_{HS} + G_S + 2T_{PLU} + 2T_{BBU}$$

For specimen strengths greater than 35 MPa [5000 psi]:

$$MSW_{UP}, \text{ mm [in.]} = D_{HS} + G_S + T_{PLU} + T_{BBU}$$

where:

MBW_{UP} = maximum bearing width of upper platen, mm [in.],

MSW_{UP} = maximum support width of upper platen, mm [in.],

D_{HS} = diameter of hemispherical head socket, mm [in.],

G_S = gap from the socket to the top surface of the platen, mm [in.],

T_{PLU} = thickness of upper platen, mm [in.], and

T_{BBU} = thickness of upper bearing block (if used), mm [in.].

A1.2.3 *Lower Platen*—The maximum bearing dimensions of the lower platen, MBW_{LP} and MSW_{LP} , shall be calculated as follows (See Fig. A1.2):

For specimen strengths up to 35 MPa [5000 psi]:

$$MBW_{LP}, \text{ mm [in.]} = D_S + 2T_{PLL} + 2T_{BBL}$$

For specimen strengths greater than 35 MPa [5000 psi]:

$$MSW_{LP}, \text{ mm [in.]} = D_S + T_{PLL} + T_{BBL}$$

where:

MBW_{LP} = maximum bearing width of lower platen, mm [in.],

MSW_{LP} = maximum support width of lower platen, mm [in.],

D_S = smaller of (i) diameter of support or (ii) minimum of the (a) thickness or (b) width of support, mm [in.],

T_{PLL} = thickness of lower platen, mm [in.], and

T_{BBL} = thickness of lower bearing block (if used), mm [in.].

GRAPHICAL SOLUTION

ASTM C1716/C1716M-18a

<https://standards.iteh.ai/catalog/standards/sist/e646ad6b-79be-4b93-8262-71ef4454962b/astm-c1716-c1716m-18a>

A1.3 Graphical Solution

A1.3.1 This section provides the details for determining the usable bearing and support area of platens and bearing blocks using the graphical method. This method is more complicated than the mathematical solution, but less conservative. The mathematical solution for determination of these properties can be found in A1.2.

A1.3.1.1 In all of the graphical solutions, the maximum support width, MSW , defines the maximum area used for specimens with strengths greater than 35 MPa [5000 psi]. It is also the support width of the platen that is used if an additional bearing block is

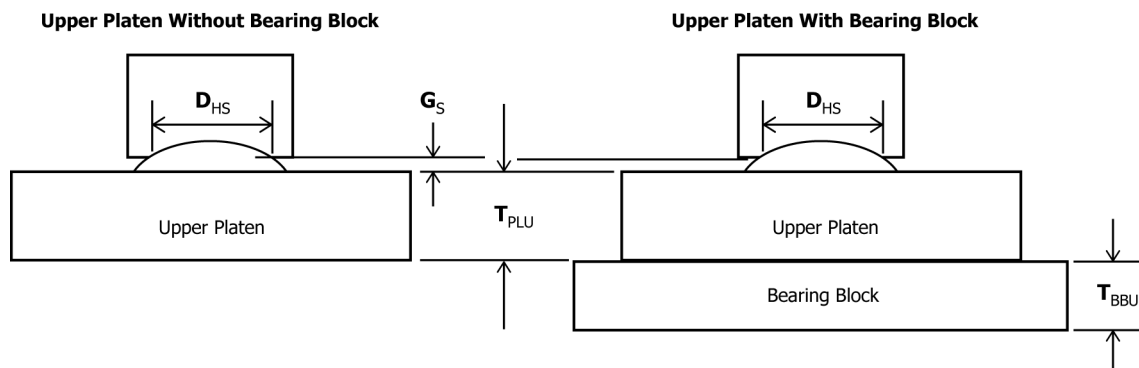

FIG. A1.1 Simplified Drawing for Determining Dimensions Used in Calculating MBW_{UP} and MSW_{UP} for Upper Platen