

INTERNATIONAL STANDARD

NORME INTERNATIONALE

Digital audio interface –
Part 1: General

ITh STANDARD PREVIEW
(standards.iteh.ai)

Interface audionumérique –
Partie 1: Généralités

<https://standards.iteh.ai/catalog/standards/sist/796023fe-d71c-49aa-8f59-1e6eac84a8d0/iec-60958-1-2021>
IEC 60958-1:2021



THIS PUBLICATION IS COPYRIGHT PROTECTED

Copyright © 2021 IEC, Geneva, Switzerland

All rights reserved. Unless otherwise specified, no part of this publication may be reproduced or utilized in any form or by any means, electronic or mechanical, including photocopying and microfilm, without permission in writing from either IEC or IEC's member National Committee in the country of the requester. If you have any questions about IEC copyright or have an enquiry about obtaining additional rights to this publication, please contact the address below or your local IEC member National Committee for further information.

Droits de reproduction réservés. Sauf indication contraire, aucune partie de cette publication ne peut être reproduite ni utilisée sous quelque forme que ce soit et par aucun procédé, électronique ou mécanique, y compris la photocopie et les microfilms, sans l'accord écrit de l'IEC ou du Comité national de l'IEC du pays du demandeur. Si vous avez des questions sur le copyright de l'IEC ou si vous désirez obtenir des droits supplémentaires sur cette publication, utilisez les coordonnées ci-après ou contactez le Comité national de l'IEC de votre pays de résidence.

IEC Central Office
3, rue de Varembe
CH-1211 Geneva 20
Switzerland

Tel.: +41 22 919 02 11
info@iec.ch
www.iec.ch

About the IEC

The International Electrotechnical Commission (IEC) is the leading global organization that prepares and publishes International Standards for all electrical, electronic and related technologies.

About IEC publications

The technical content of IEC publications is kept under constant review by the IEC. Please make sure that you have the latest edition, a corrigendum or an amendment might have been published.

IEC publications search - webstore.iec.ch/advsearchform

The advanced search enables to find IEC publications by a variety of criteria (reference number, text, technical committee, ...). It also gives information on projects, replaced and withdrawn publications.

IEC online collection - oc.iec.ch

Discover our powerful search engine and read freely all the publications previews. With a subscription you will always have access to up to date content tailored to your needs.

IEC Just Published - webstore.iec.ch/justpublished

Stay up to date on all new IEC publications. Just Published details all new publications released. Available online and once a month by email.

Electropedia - www.electropedia.org

The world's leading online dictionary on electrotechnology, containing more than 22 000 terminological entries in English and French, with equivalent terms in 18 additional languages. Also known as the International Electrotechnical Vocabulary (IEV) online

IEC Customer Service Centre - webstore.iec.ch/csc

If you wish to give us your feedback on this publication or need further assistance, please contact the Customer Service Centre: sales@iec.ch.

A propos de l'IEC

La Commission Electrotechnique Internationale (IEC) est la première organisation mondiale qui élabore et publie des Normes internationales pour tout ce qui a trait à l'électricité, à l'électronique et aux technologies apparentées.

A propos des publications IEC

Le contenu technique des publications IEC est constamment revu. Veuillez vous assurer que vous possédez l'édition la plus récente, un corrigendum ou amendement peut avoir été publié.

Recherche de publications IEC -

webstore.iec.ch/advsearchform

La recherche avancée permet de trouver des publications IEC en utilisant différents critères (numéro de référence, texte, comité d'études, ...). Elle donne aussi des informations sur les projets et les publications remplacées ou retirées.

Découvrez notre puissant moteur de recherche et consultez gratuitement tous les aperçus des publications. Avec un abonnement, vous aurez toujours accès à un contenu à jour adapté à vos besoins.

IEC Just Published - webstore.iec.ch/justpublished

Restez informé sur les nouvelles publications IEC. Just Published détaille les nouvelles publications parues. Disponible en ligne et une fois par mois par email.

Electropedia - www.electropedia.org

Le premier dictionnaire d'électrotechnologie en ligne au monde, avec plus de 22 000 articles terminologiques en anglais et en français, ainsi que les termes équivalents dans 16 langues additionnelles. Egalement appelé Vocabulaire Electrotechnique International (IEV) en ligne.

Service Clients - webstore.iec.ch/csc

Si vous désirez nous donner des commentaires sur cette publication ou si vous avez des questions contactez-nous: sales@iec.ch.

IEC online collection - oc.iec.ch

INTERNATIONAL STANDARD

NORME INTERNATIONALE

Digital audio interface –
Part 1: General

STANDARD PREVIEW
(standards.iteh.ai)

Interface audionumérique –
Partie 1: Généralités

standards.iteh.ai/catalog/standards/sist/796023fe-d71c-49aa-8f59-1e6eac84a8d0/iec-60958-1-2021
IEC 60958-1:2021

INTERNATIONAL
ELECTROTECHNICAL
COMMISSION

COMMISSION
ELECTROTECHNIQUE
INTERNATIONALE

ICS 33.160.01

ISBN 978-2-8322-1053-0

Warning! Make sure that you obtained this publication from an authorized distributor.
Attention! Veuillez vous assurer que vous avez obtenu cette publication via un distributeur agréé.

CONTENTS

FOREWORD	4
1 Scope	6
2 Normative references	6
3 Terms and definitions	6
4 Interface format	8
4.1 Structure of format	8
4.1.1 Sub-frame format	8
4.1.2 Frame format	9
4.2 Channel coding	10
4.3 Preambles	10
4.4 Validity bit	11
5 Channel status	11
5.1 General	11
5.2 Applications	11
5.3 General assignment of the first and second channel status bits	11
5.4 Category code	12
6 User data	14
6.1 General	14
6.2 Applications	14
6.2.1 Professional use	14
6.2.2 Consumer use	14
7 Electrical requirements	14
7.1 Consumer application	14
7.1.1 General	14
7.1.2 Timing accuracy	14
7.1.3 Unbalanced line	15
7.2 Professional application	18
8 Optical requirements	18
8.1 Consumer application	18
8.1.1 Configuration of optical connection	18
8.1.2 Optical connector	18
8.2 Professional applications	19
Annex A (informative) The use of the validity bit	20
Annex B (informative) Application documents and specifications	21
Annex C (informative) A relationship of the IEC 60958 series families	22
Annex D (informative) Transmission of CD data other than linear PCM audio	24
Annex E (informative) The IEC 60958 series conformant data format	25
Annex F (informative) Stream change	26
Annex G (informative) Characteristics of optical connection	28
Bibliography	30
Figure 1 – Sub-frame format (linear PCM application)	9
Figure 2 – Frame format	9
Figure 3 – Channel coding	10

Figure 4 – Preamble M (shown as 11100010)	11
Figure 5 – Simplified example of the configuration of the circuit (unbalanced).....	15
Figure 6 – Rise and fall times	16
Figure 7 – Intrinsic jitter measurement filter	16
Figure 8 – Eye diagram.....	17
Figure 9 – Receiver jitter tolerance template.....	17
Figure 10 – Basic optical connection.....	18
Figure C.1 – Relationships of the IEC 60958 families.....	22
Figure F.1 – Audio sources and AV receiver model.....	26
Figure F.2 – Switching from linear PCM to non linear PCM	26
Figure F.3 – Switching from non linear PCM to linear PCM	27
Figure F.4 – Switching from non-linear PCM to non-linear PCM	27
Table 1 – Preamble coding	10
Table 2 – Channel status data format	13
Table B.1 – Application documents and specifications	21
Table C.1 – data_type values and application	23
Table G.1 – Characteristics of standard optical connection (optical interface).....	28
Table G.2 – Characteristics of optical transmitter (optical interface).....	28
Table G.3 – Characteristics of optical receiver (optical interface).....	29
Table G.4 – Characteristics of fibre optic cable.....	29
Table G.5 – Optical power budget for the link with plastic fibre.....	29

INTERNATIONAL ELECTROTECHNICAL COMMISSION

DIGITAL AUDIO INTERFACE –**Part 1: General****FOREWORD**

- 1) The International Electrotechnical Commission (IEC) is a worldwide organization for standardization comprising all national electrotechnical committees (IEC National Committees). The object of IEC is to promote international co-operation on all questions concerning standardization in the electrical and electronic fields. To this end and in addition to other activities, IEC publishes International Standards, Technical Specifications, Technical Reports, Publicly Available Specifications (PAS) and Guides (hereafter referred to as “IEC Publication(s)”). Their preparation is entrusted to technical committees; any IEC National Committee interested in the subject dealt with may participate in this preparatory work. International, governmental and non-governmental organizations liaising with the IEC also participate in this preparation. IEC collaborates closely with the International Organization for Standardization (ISO) in accordance with conditions determined by agreement between the two organizations.
- 2) The formal decisions or agreements of IEC on technical matters express, as nearly as possible, an international consensus of opinion on the relevant subjects since each technical committee has representation from all interested IEC National Committees.
- 3) IEC Publications have the form of recommendations for international use and are accepted by IEC National Committees in that sense. While all reasonable efforts are made to ensure that the technical content of IEC Publications is accurate, IEC cannot be held responsible for the way in which they are used or for any misinterpretation by any end user.
- 4) In order to promote international uniformity, IEC National Committees undertake to apply IEC Publications transparently to the maximum extent possible in their national and regional publications. Any divergence between any IEC Publication and the corresponding national or regional publication shall be clearly indicated in the latter.
- 5) IEC itself does not provide any attestation of conformity. Independent certification bodies provide conformity assessment services and, in some areas, access to IEC marks of conformity. IEC is not responsible for any services carried out by independent certification bodies.
- 6) All users should ensure that they have the latest edition of this publication.
- 7) No liability shall attach to IEC or its directors, employees, servants or agents including individual experts and members of its technical committees and IEC National Committees for any personal injury, property damage or other damage of any nature whatsoever, whether direct or indirect, or for costs (including legal fees) and expenses arising out of the publication, use of, or reliance upon, this IEC Publication or any other IEC Publications.
- 8) Attention is drawn to the Normative references cited in this publication. Use of the referenced publications is indispensable for the correct application of this publication.
- 9) Attention is drawn to the possibility that some of the elements of this IEC Publication may be the subject of patent rights. IEC shall not be held responsible for identifying any or all such patent rights.

IEC 60958-1 has been prepared by technical area 20: Analogue and digital audio, of IEC technical committee 100: Audio, video and multimedia systems and equipment. It is an International Standard.

This fourth edition cancels and replaces the third edition published in 2008, and Amendment 1:2014. This edition constitutes a technical revision.

This edition includes the following significant technical changes with respect to the previous edition:

- a) The relevant part of IEC 60958-5 is supported.

The text of this International Standard is based on the following documents:

Draft	Report on voting
100/3544/CDV	100/3593/RVC

Full information on the voting for its approval can be found in the report on voting indicated in the above table.

The language used for the development of this International Standard is English.

A list of all parts of the IEC 60958 series, under the general title *Digital audio interface*, can be found on the IEC website.

This document was drafted in accordance with ISO/IEC Directives, Part 2, and developed in accordance with ISO/IEC Directives, Part 1 and ISO/IEC Directives, IEC Supplement, available at www.iec.ch/members_experts/refdocs. The main document types developed by IEC are described in greater detail at www.iec.ch/standardsdev/publications.

The committee has decided that the contents of this document will remain unchanged until the stability date indicated on the IEC website under webstore.iec.ch in the data related to the specific document. At this date, the document will be

- reconfirmed,
- withdrawn,
- replaced by a revised edition, or
- amended.

iTeh STANDARD PREVIEW
(standards.iteh.ai)

<https://standards.iteh.ai/catalog/standards/sist/796023fe-d71c-49aa-8f59-1e6eac84a8d0/iec-60958-1-2021>

DIGITAL AUDIO INTERFACE –

Part 1: General

1 Scope

This part of IEC 60958 describes a serial, uni-directional, self-clocking interface for the interconnection of digital audio equipment for consumer and professional applications.

It provides the basic structure of the interface. Separate documents define items specific to particular applications.

The interface is primarily intended to carry monophonic or stereophonic programmes, encoded using linear PCM and with a resolution of up to 24 bits per sample.

When used for other purposes, the interface is able to carry audio data coded other than as linear PCM coded audio samples. Provision is also made to allow the interface to carry data related to computer software, multimedia technologies, or signals coded using non-linear PCM. The format specification for these applications is not part of this document.

The interface is intended for operation at audio sampling frequencies of 32 kHz and above. Auxiliary information is transmitted along with the programme.

2 Normative references

[IEC 60958-1:2021](#)

<https://standards.iteh.ai/catalog/standards/sist/796023fe-d71c-49aa-8f59-1e5cc84a8d9/iec-60958-1-2021>

The following documents are referred to in the text in such a way that some or all of their content constitutes requirements of this document. For dated references, only the edition cited applies. For undated references, the latest edition of the referenced document (including any amendments) applies.

IEC 60268-11:1987, *Sound system equipment – Part 11: Application of connectors for the interconnection of sound system components*

IEC 60958-3, *Digital audio interface – Part 3: Consumer applications*

IEC 60958-4 (all parts), *Digital audio interface – Part 4: Professional applications*

IEC 60958-5, *Digital audio interface – Part 5: Consumer application enhancement*

3 Terms and definitions

For the purposes of this document, the following terms and definitions apply.

ISO and IEC maintain terminological databases for use in standardization at the following addresses:

- IEC Electropedia: available at <http://www.electropedia.org/>
- ISO Online browsing platform: available at <http://www.iso.org/obp>

3.1

sampling frequency

frequency of the samples representing an audio signal

Note 1 to entry: When more than one signal is transmitted through the same interface, the sampling frequencies are identical.

3.2

audio sample word

value of a digital audio sample; representation is linear in 2's complement binary form

Note 1 to entry: Positive numbers correspond to positive analogue voltages at the input of the analogue-to-digital converter (ADC).

3.3

auxiliary sample bit

four least significant bits (LSBs) which can be assigned as auxiliary sample bits and used for auxiliary information when the number of audio sample bits in the main data field is less than or equal to 20

3.4

validity bit

bit indicating whether the main data field bits in the sub-frame (time slots 4 to 27 or 8 to 27, depending on the audio word length as described in 4.1.1) are reliable or not

3.5

channel status

data carrying, in a fixed format, information associated with each main data field channel which is decodable by any interface user

Note 1 to entry: Examples of information to be carried in the channel status are: length of audio sample words, pre-emphasis, sampling frequency, time codes, alphanumeric source and destination codes.

3.6

user data

data provided to carry any other information

3.7

parity bit

bit provided to permit the detection of an odd number of errors resulting from malfunctions in the interface

3.8

preamble

specific patterns used for synchronization

Note 1 to entry: There are three different preambles (see 4.3).

3.9

sub-frame

fixed structure used to carry information (see 4.1.1 and 4.1.2)

3.10

frame

sequence of two successive and associated sub-frames

3.11

block

group of 192 consecutive frames

Note 1 to entry: The start of a block is designated by a special sub-frame preamble (see 4.3).

3.12

channel coding

coding method by which the binary digits are represented for transmission through the interface

3.13**unit interval (UI)**

shortest nominal time interval in the coding scheme

Note 1 to entry: There are 128 UI in a sample frame.

3.14**interface jitter**

deviation in the timing of interface data transitions (zero crossings) when compared with an ideal clock

3.15**intrinsic jitter**

output interface jitter of a device that is either free-running or is synchronized to a jitter-free reference

3.16**jitter gain**

ratio of the amplitude of jitter components at the output to their amplitude at the synchronization input to the device under test

4 Interface format**4.1 Structure of format****4.1.1 Sub-frame format**

Each sub-frame is divided into 32 time slots, numbered from 0 to 31 (see Figure 1).

Time slots 0 to 3 (preambles) carry one of the three permitted preambles (see 4.1.2 and 4.3; also see Figure 2).

Time slots 4 to 27 (main data field) carry the audio sample word in linear 2's complement representation. The most significant bit (MSB) is carried by time slot 27.

When a 24-bit coding range is used, the LSB is in time slot 4 (see Figure 1).

When a 20-bit coding range is used, time slots 8 to 27 carry the audio sample word with the LSB in time slot 8. Time slots 4 to 7 may be used for other applications. Under these circumstances, the bits in the time slots 4 to 7 are designated auxiliary sample bits (see Figure 1).

If the source provides fewer bits than the interface allows (either 20 or 24), the unused LSBs are set to a logical "0".

For a non-linear PCM audio application or a data application the main data field may carry any other information.

Time slot 28 (validity bit) carries the validity bit associated with the main data field (see 4.4).

Time slot 29 (user data bit) carries 1 bit of the user data channel associated with the main data field channel transmitted in the same sub-frame. For the applications, refer to the other parts of IEC 60958.

Time slot 30 (channel status bit) carries 1 bit of the channel status information associated with the main data field channel transmitted in the same sub-frame. For details refer to the other parts of IEC 60958.

Time slot 31 (parity bit) carries a parity bit such that time slots 4 to 31 inclusive carry an even number of ones and an even number of zeroes (even parity).

NOTE The preambles have even parity as an explicit property.

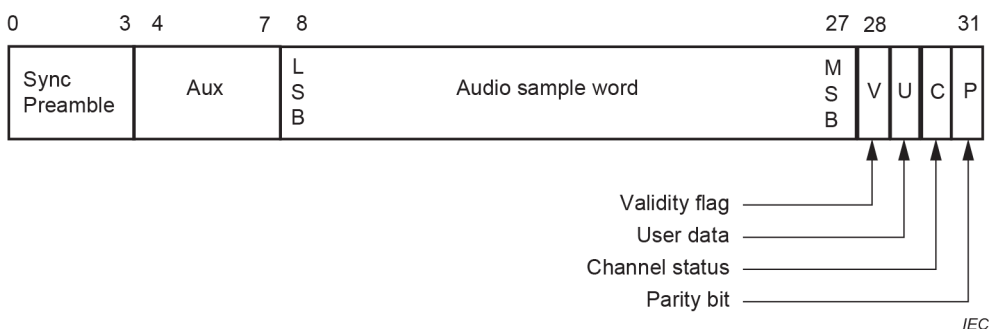

Figure 1 – Sub-frame format (linear PCM application)

Annex E describes the IEC 60958 series conformant data format that utilises the sub-frame format.

4.1.2 Frame format

A frame is uniquely composed of two sub-frames (see Figure 2). For linear coded audio applications, the rate of transmission of frames normally corresponds exactly to the source sampling frequency.

(standards.iteh.ai)

In 2-channel operation mode, the samples taken from both channels are transmitted by time multiplexing in consecutive sub-frames. The first sub-frame (left or "A" channel in stereophonic operation and primary channel in monophonic operation) normally starts with preamble "M". However, the preamble changes to preamble "B" once every 192 frames to identify the start of the block structure used to organize the channel status information. The second sub-frame (right or "B" channel in stereophonic operation and secondary channel in monophonic operation) always starts with preamble "W".

In single channel operation mode in a professional application, the frame format is the same as in the 2-channel mode. Data is carried in the first sub-frame and may be duplicated in the second sub-frame. If the second sub-frame is not carrying duplicate data, then time slot 28, (validity flag) shall be set to logical "1".

NOTE For historical reasons preambles "B", "M" and "W" are, for use in professional applications, referred to as "Z", "X" and "Y", respectively.

Annex C describes the relation of the IEC 60958 series families based on the frame format.

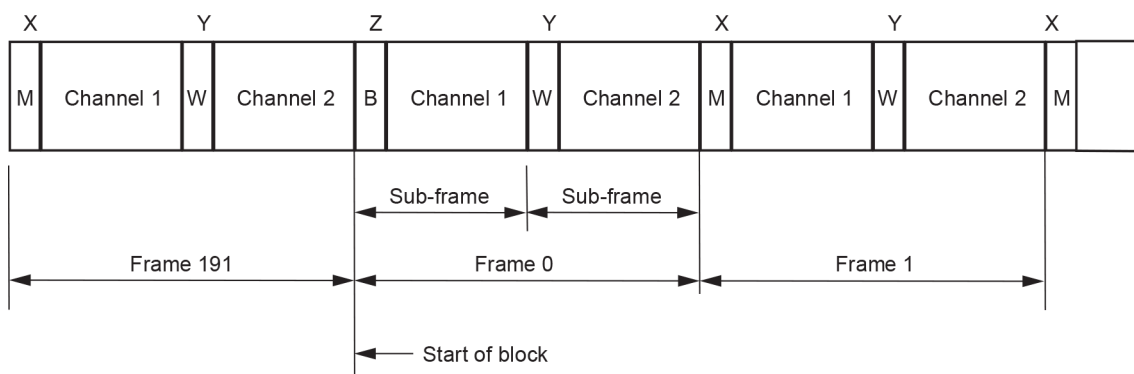

Figure 2 – Frame format

4.2 Channel coding

To minimize the direct current (d.c.) component on the transmission line, to facilitate clock recovery from the data stream and to make the interface insensitive to the polarity of connections, time slots 4 to 31 are encoded in biphasemark.

Each bit to be transmitted is represented by a symbol comprising two consecutive binary states. The first state of a symbol is always different from the second state of the previous symbol. The second state of the symbol is identical to the first if the bit to be transmitted is logical "0". However, it is different if the bit is logical "1" (see Figure 3).

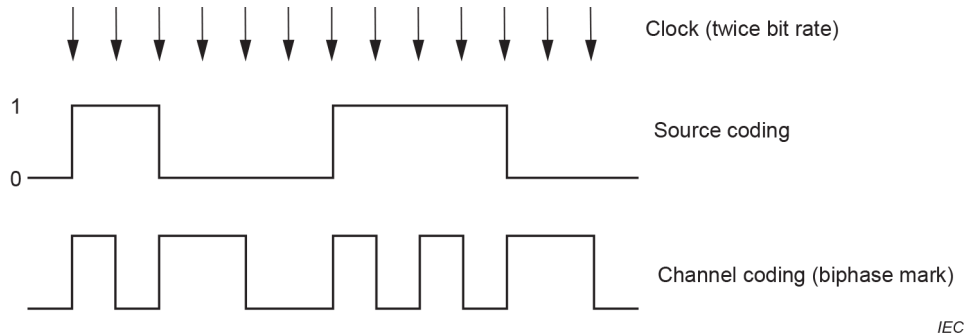

Figure 3 – Channel coding

4.3 Preambles

iTeh STANDARD PREVIEW
(standards.iteh.ai)

Preambles are specific patterns providing synchronization and identification of the sub-frames and blocks.

IEC 60958-1:2021

To achieve synchronization within one sampling period and to make this process completely reliable, these patterns violate the biphasemark code rules, thereby avoiding the possibility of data imitating the preambles.

A set of three preambles is used. These preambles are transmitted in the time allocated to four time slots at the start of each sub-frame (time slots 0 to 3), and are represented by eight successive states. The first state of the preamble is always different from the second state of the previous symbol (representing the parity bit). Depending on this state, the preambles are as shown in Table 1.

Table 1 – Preamble coding

Preceding state	0	1	
Preamble code	Channel coding		
"B" or "Z" (see note to 4.1.2)	11101000	00010111	Sub-frame 1 and the start of the block
"M" or "X"	11100010	00011101	Sub-frame 1
"W" or "Y"	11100100	00011011	Sub-frame 2

Like biphasemark code, these preambles are d.c. free and provide clock recovery. They differ in at least two states from any valid biphasemark sequence.

Figure 4 represents preamble "M".

NOTE Owing to the even-parity bit in time slot 31, all preambles start with a transition in the same direction (see 4.1.1). Thus, only one of these sets of preambles is, in practice, transmitted through the interface. However, it is necessary for both sets to be decodable because either polarity is possible in a connection.

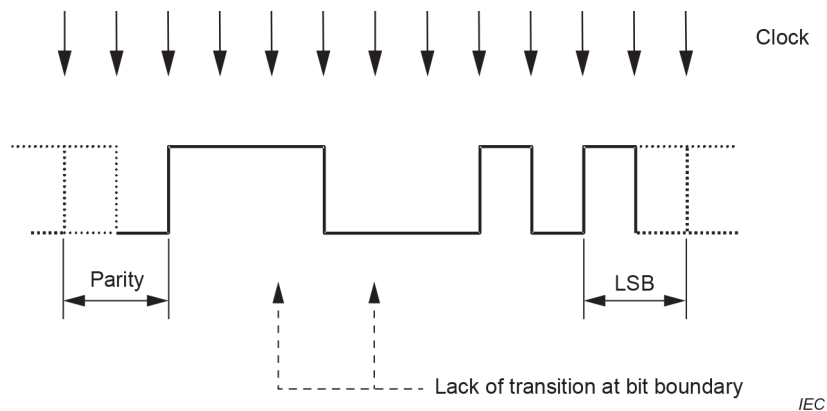

Figure 4 – Preamble M (shown as 11100010)

4.4 Validity bit

The validity bit is logical "0" if the information in the main data field is reliable, and it is logical "1" if it is not. There is no default state for the validity bit.

NOTE For transmissions not using a linear PCM coding, this bit can be set. This is intended to prevent accidental decoding of non-audio data to analogue before a complete channel status block is received. See Annex A.

5 Channel status iTeH STANDARD PREVIEW (standards.iteh.ai)

5.1 General

For every sub-frame, the channel status information related to the data carried in the main data field of that same sub-frame. [IEC 60958-1:2021](https://standards.iteh.ai/catalog/standards/sist/796023fe-d71c-49aa-8f59-1e6eac84a8d0/iec-60958-1-2021)

Channel status information is organised in a 192-bit block, subdivided into 24 bytes. The first bit of each block is carried in the frame with preamble "B". The channel status data format is defined in Table 2.

The specific organisation depends on the application. In the descriptions, the suffix "0" designates the first byte or bit. Where channel status bits are combined to form non-binary values, the least significant bit should be transmitted first, unless otherwise indicated.

5.2 Applications

The primary application is indicated by the first channel status bit (bit 0) of a block as defined in 5.3.

For professional applications, refer to IEC 60958-4.

For consumer applications, refer to IEC 60958-3 and IEC 60958-5.

Secondary applications may be defined within the framework of these primary applications.

Application documents or specifications are listed in Annex B.

5.3 General assignment of the first and second channel status bits

The first and second channel status bits (bit 0 and bit 1) are specified as follows.

Byte 0

Bit 0 "0" Consumer use of channel status block.

	"1"	Professional use of channel status block.
Bit 1	"0"	Main data field represents linear PCM samples.
	"1"	Main data field used for other purposes.

Annex D describes an exception case of bit 1 status. Annex F describes a receiver's behaviour when bit 1 is being altered.

5.4 Category code

Channel status including category code is defined in IEC 60958-3 for consumer applications; these category codes are used for other variations of IEC 60958 for consumer use, such as IEC 61937.

Also, channel status is defined in IEC 60958-4 for professional applications; these channel statuses are used for other variations for professional use such as SMPTE ST 337 and others.

iTeh STANDARD PREVIEW (standards.iteh.ai)

[IEC 60958-1:2021](https://standards.iteh.ai/catalog/standards/sist/796023fe-d71c-49aa-8f59-1e6eac84a8d0/iec-60958-1-2021)

<https://standards.iteh.ai/catalog/standards/sist/796023fe-d71c-49aa-8f59-1e6eac84a8d0/iec-60958-1-2021>

Table 2 – Channel status data format

Byte		a	b						
0	bit	0	1	2	3	4	5	6	7
1	bit	8	9	10	11	12	13	14	15
2	bit	16	17	18	19	20	21	22	23
3	bit	24	25	26	27	28	29	30	31
4	bit	32	33	34	35	36	37	38	39
5	bit	40	41	42	43	44	45	46	47
6	bit	48	49	50	51	52	53	54	55
7	bit	56	57	58	59	60	61	62	63
8	bit	64	65	66	67	68	69	70	71
9	bit	72	73	74	75	76	77	78	79
10	bit	80	81	82	83	84	85	86	87
11	bit	88	89	90	91	92	93	94	95
12	bit	96	97	98	99	100	101	102	103
13	bit	104	105	106	107	108	109	110	111
14	bit	112	113	114	115	116	117	118	119
15	bit	120	121	122	123	124	125	126	127
16	bit	128	129	130	131	132	133	134	135
17	bit	136	137	138	139	140	141	142	143
18	bit	144	145	146	147	148	149	150	151
19	bit	152	153	154	155	156	157	158	159
20	bit	160	161	162	163	164	165	166	167
21	bit	168	169	170	171	172	173	174	175
22	bit	176	177	178	179	180	181	182	183
23	bit	184	185	186	187	188	189	190	191
		a: use of channel status block.							
		b: linear PCM identification.							