

Revisée

**ISO**

INTERNATIONAL ORGANIZATION FOR STANDARDIZATION

**ISO RECOMMENDATION  
R 60**

**PLASTICS**

**DETERMINATION OF APPARENT DENSITY  
OF MOULDING MATERIAL  
THAT CAN BE POURED FROM A SPECIFIED FUNNEL**

**1st EDITION**

**April 1958**

**COPYRIGHT RESERVED**

The copyright of ISO Recommendations and ISO Standards belongs to ISO Member Bodies. Reproduction of these documents, in any country, may be authorized therefore only by the national standards organization of that country, being a member of ISO.

For each individual country the only valid standard is the national standard of that country.

Printed in Switzerland

Also issued in French and Russian. Copies to be obtained through the national standards organizations.

## BRIEF HISTORY

The ISO Recommendation R 60, *Determination of Apparent Density of Moulding Material that can be Poured from a Specified Funnel*, was prepared by Technical Committee ISO/TC 61, *Plastics*, the Secretariat of which is held by the American Standards Association, Incorporated (ASA).

At its second meeting, held in Turin, in October 1952, the Technical Committee assigned the development of this question to its Working Group No. 5, *Physical Chemical Properties*, under the leadership of the United Kingdom.

The draft formulated by the Working Group, was presented to the Technical Committee at its third plenary meeting, held at Stockholm, in August 1953, and then distributed to the members of the Technical Committee as a draft proposal for an ISO Recommendation.

After its reconsideration at the fourth meeting of ISO/TC 61, held in Brighton, in October 1954, the draft proposal was adopted, subject to some amendments, as a Draft ISO Recommendation.

On 31 December 1955, the Draft ISO Recommendation was circulated to all the ISO Member Bodies and, some amendments having been taken into consideration, it was approved by the following 29 Member Bodies (out of a total of 37):

Australia	India	Portugal
Austria	Ireland	Spain
Belgium	Israel	Sweden
Chile	Italy	Turkey
Czechoslovakia	Japan	Union of South Africa
*Denmark	Mexico	United Kingdom
Finland	Netherlands	U.S.A.
France	New Zealand	U.S.S.R.
Germany	Pakistan	Yugoslavia
*Greece	Poland	

No Member Body opposed approval of the Draft.

The Draft ISO Recommendation was then submitted, by correspondence, to the ISO Council, which decided, in April 1958, to accept it as an ISO RECOMMENDATION.

\* These Member Bodies stated that they had no objection to the Draft being approved.

## PLASTICS

### DETERMINATION OF APPARENT DENSITY OF MOULDING MATERIAL THAT CAN BE Poured FROM A SPECIFIED FUNNEL

#### 1. SCOPE

- 1.1 This method of test describes the procedure for determining the apparent density, i.e. the weight per unit of volume, of loose moulding material that can be poured from a funnel of specified design.
- 1.2 When the method is applied to relatively coarse materials, rather variable results may be obtained, owing to the error introduced when a straight-edge blade is drawn across the top of the cylinder.
- 1.3 A knowledge of apparent density is of limited value in estimating the relative fluffiness or bulk of moulding materials, unless their specific gravities in the moulded condition are approximately the same.

#### 2. APPARATUS

- 2.1 The apparatus consists of the following:

- (a) balance to weigh to 0.1 g;
- (b) measuring cylinder, smoothly finished inside, which may be constructed of metal, of a capacity of 100 ml  $\pm$  0.5 ml and an internal diameter of 45 mm  $\pm$  5 mm;
- (c) funnel of the form and dimensions shown in the figure.

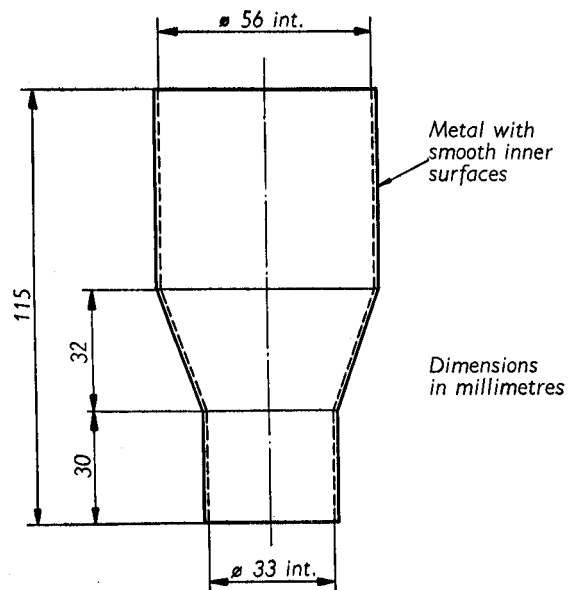

FUNNEL