



Designation: **F3117–18b F3117/F3117M – 18c**

## Standard Specification for Crew Interface in Aircraft<sup>1</sup>

This standard is issued under the fixed designation ~~F3117~~F3117/F3117M; the number immediately following the designation indicates the year of original adoption or, in the case of revision, the year of last revision. A number in parentheses indicates the year of last reapproval. A superscript epsilon ( $\epsilon$ ) indicates an editorial change since the last revision or reapproval.

### 1. Scope

1.1 This specification covers international standards for the crew interface aspects of airworthiness and design for aircraft. “Crew” includes flight crew and maintenance crew. The material was developed through open consensus of international experts in general aviation. This information was created by focusing on Normal Category aeroplanes. The content may be more broadly applicable; it is the responsibility of the applicant to substantiate broader applicability as a specific means of compliance.

1.2 ~~The applicant~~An applicant intending to propose this information as Means of Compliance for a design approval must seek the individual guidance of their respective Civil Aviation Authority (CAA) body concerning the use of this standard as part of a certification plan from their respective oversight authority (for example, published guidance from applicable CAAs) concerning the acceptable use and application thereof. For information on which CAA regulatory bodies oversight authorities have accepted this standard specification (in whole or in part) as a means of compliance an acceptable Means of Compliance to their airworthiness regulations (hereinafter referred to as regulatory requirements (hereinafter “the Rules”), refer to ASTM F44 webpage ([www.ASTM.org/COMMITTEE/F44.htm](http://www.ASTM.org/COMMITTEE/F44.htm)) which includes CAA website links. Committee F44 web page (<https://www.astm.org/COMMITTEE/F44.htm>).

1.3 *Units*—This document may present information in either SI units, English Engineering units, or both. The values stated in each system may not be exact equivalents; therefore, each system shall be used independently of the other. Combining values from the two systems may result in nonconformance with the standard.

1.4 *This standard does not purport to address all of the safety concerns, if any, associated with its use. It is the responsibility of the user of this standard to establish appropriate safety, health, and environmental practices and determine the applicability of regulatory limitations prior to use.*

1.5 *This international standard was developed in accordance with internationally recognized principles on standardization established in the Decision on Principles for the Development of International Standards, Guides and Recommendations issued by the World Trade Organization Technical Barriers to Trade (TBT) Committee.*

### 2. Referenced Documents

#### 2.1 ASTM Standards:<sup>2</sup>

- [F3060 Terminology for Aircraft](#)
- [F3061/F3061M Specification for Systems and Equipment in Small Aircraft](#)
- [F3064/F3064M Specification for Aircraft Powerplant Control, Operation, and Indication](#)
- [F3116/F3116M Specification for Design Loads and Conditions](#)
- [F3173/F3173M Specification for Aircraft Handling Characteristics](#)
- [F3174/F3174M Specification for Establishing Operating Limitations and Information for Aeroplanes](#)
- [F3179/F3179M Specification for Performance of Aircraft](#)
- [F3233/F3233M Specification for Instrumentation in Small Aircraft](#)
- [F3235 Specification for Aircraft Storage Batteries](#)

#### 2.2 Code of Federal Regulations (CFR):<sup>3</sup>

- [14 CFR Part 23 Amendment 62](#)

<sup>1</sup> This specification is under the jurisdiction of ASTM Committee F44 on General Aviation Aircraft and is the direct responsibility of Subcommittee F44.10 on General. Current edition approved May 1, 2018/Nov. 1, 2018. Published July 2018/December 2018. Originally approved in 2015. Last previous edition approved in 2018 as F3117–18a, F3117–18b. DOI: 10.1520/F3117-18B, 10.1520/F3117\_F3117M-18C.

<sup>2</sup> For referenced ASTM standards, visit the ASTM website, [www.astm.org](http://www.astm.org), or contact ASTM Customer Service at [service@astm.org](mailto:service@astm.org). For *Annual Book of ASTM Standards* volume information, refer to the standard’s Document Summary page on the ASTM website.

<sup>3</sup> Available from U.S. Government Printing Office, Superintendent of Documents, Publishing Office (GPO), 732 N. Capitol St., NW, Washington, DC 20401-0001; <http://www.access.gpo.gov/20401>, <http://www.gpo.gov>.

### 3. Terminology

3.1 Refer to Terminology F3060.

### 4. ~~Pilot/Occupant~~ Pilot/Occupant Compartment

4.1 *Pilot Compartment:*

4.1.1 For each pilot compartment, the compartment and its equipment must allow each pilot to perform flight crew duties without unreasonable concentration or fatigue.

4.1.2 For each pilot compartment, where the flight crew are separated from the passengers by a partition, there must be a means to facilitate two-way communication between flight crew and cabin occupants, such as an opening or openable window or door or other means.

iTeh Standards  
(<https://standards.iteh.ai>)  
Document Preview

[ASTM F3117/F3117M-18c](https://standards.iteh.ai/catalog/standards/sist/7e88fdb1-8ceb-4fe4-a05e-9272a4b3a4aa/astm-f3117-f3117m-18c)

<https://standards.iteh.ai/catalog/standards/sist/7e88fdb1-8ceb-4fe4-a05e-9272a4b3a4aa/astm-f3117-f3117m-18c>

NOTE 1—A single intercom port from passenger compartment to crew may suffice as other means. If an opening is not provided to allow visual verification of occupant compartment conditions, such as Oxygen System status in Specification F3061/F3061M, other indication means may be required for other systems.

4.1.3 If communication between flight crew and cabin occupants relies on electrical power, the one-way communication from the flight crew to the cabin occupants must be considered an essential electrical load.

#### 4.2 Pilot Compartment View:

4.2.1 Each pilot compartment must be arranged with sufficiently clear and undistorted view to enable the pilot to safely taxi, takeoff, approach, land, and perform any maneuvers within the operating limitations of the aircraft.

4.2.2 Each pilot compartment must be free from glare and reflections that could interfere with the pilot's vision. Compliance must be shown in all operations for which certification is requested.

4.2.3 Each pilot compartment must be designed so that each pilot is protected from the elements so that moderate rain conditions do not unduly impair the pilot's view of the flight path in normal flight and while landing.

4.2.4 A vision system with a transparent display surface located in the pilot's outside field of view, such as a head up-display, head mounted display, or other equivalent display, must meet the following requirements:

4.2.4.1 While the vision system display is in operation, it must compensate for interference with the pilot's outside field of view such that the combination of what is visible in the display and what remains visible through and around it, enables the pilot to perform the maneuvers specified in 4.2.1 and the pilot compartment to meet the provisions of 4.2.2.

4.2.4.2 The pilot's view of the external scene must be free of interference, distortion, and glare, that would adversely affect the pilot's normal performance and workload, considering possible distortion both from windscreen or canopy and from transparent display surface.

4.2.4.3 The following tasks associated with the use of the pilot's view must not be degraded below the level of safety that existed without the video imagery:

(1) Detection, accurate identification and maneuvering, as necessary, to avoid traffic, terrain, obstacles, and other hazards of flight.

(2) Accurate identification and utilization of visual references required for every task relevant to the phase of flight.

(3) Although, the vision system image requirements relate primarily to the approach and landing phases of flight, the vision system image when viewed head up during ground operations should not create unacceptable distractions due to sensor proximity to the taxiway surface.

4.2.4.4 When the vision system displays imagery and any symbology referenced to the imagery and outside scene topography, including attitude symbology, flight path vector, and flight path angle reference cue, that imagery and symbology must be aligned with, and scaled to, the external scene.

4.2.4.5 The vision system must provide a means to allow the pilot using the display to immediately deactivate and reactivate the vision system imagery, on demand, without removing the pilot's hands from the primary flight controls or thrust controls.

4.2.4.6 When the vision system is not in operation, it may not restrict the pilot from performing the maneuvers specified in 4.2.1 and the pilot compartment from meeting the provisions of 4.2.2.

## 5. Controls – General

### 5.1 Flight Control Systems Controls:

5.1.1 Each control must operate easily, smoothly, and positively enough to allow proper performance of its functions.

5.1.2 Controls must be arranged and, except where their function is obvious, identified to provide for convenience in operation and to not create confusion and subsequent inadvertent operation.

5.1.3 Airplane aerodynamic flight controls must be designed so that they operate in accordance with the following movement and actuation for aerodynamic controls:

(1) Primary Controls	Motion and effect
Roll	Right (clockwise) for right wing down.
Pitch	Rearward for nose up.
Yaw	Right pedal forward for nose right.
(2) Secondary Controls	
Flaps (or auxiliary lift devices)	Forward or up for flaps up or auxiliary device stowed; rearward or down for flaps down or auxiliary device deployed.
Trim tabs (or equivalent)	Switch motion or mechanical rotation or control to produce similar rotation of the airplane about an axis parallel to the axis control. Axis of roll trim control may be displaced to accommodate comfortable actuation by the pilot. Direction of pilot's hand movement must be in the same sense as airplane response for rudder trim if only a portion of a rotational element is accessible.

### 5.2 Cockpit Controls:

5.2.1 Each cockpit control must be located and, except where its function is obvious, identified to provide convenient operation and to not create confusion or be prone to inadvertent operation.

5.2.2 The controls must be located and arranged so that the pilot, in the normal seated position in the cockpit, has full and unrestricted movement of each control without interference from either clothing or cockpit structure.

5.2.3 Detents are an acceptable means to establish control positions associated with particular actions.

5.2.4 Powerplant controls must be located:

5.2.4.1 For multiengine airplanes, powerplant controls must be located on the pedestal or overhead at or near the center of the cockpit.

5.2.4.2 For single and tandem seated single-engine airplanes, powerplant controls must be located on the left side of the console or instrument panel.

5.2.4.3 For other single-engine airplanes, powerplant controls must be located at or near the center of the cockpit, on the pedestal, instrument panel, or overhead.

5.2.4.4 For airplanes with side-by-side pilot seats and with two sets of powerplant controls, powerplant controls must be located on the left and right consoles.

5.2.5 When separate and distinct control levers are co-located (such as located together on the pedestal), the control location order from left to right must be power (thrust) lever, propeller (rpm control), and mixture control (condition lever and fuel cut-off for turbine-powered airplanes).

5.2.5.1 Power (thrust) levers must be easily distinguishable from other controls, and provide for accurate, consistent operation.

5.2.5.2 Carburetor heat or alternate air control must be to the left of the throttle or at least 20 cm (8 in.) [8 in.] from the mixture control when located other than on a pedestal.

5.2.5.3 Carburetor heat or alternate air control, when located on a pedestal, must be aft or below the power (thrust) lever.

5.2.5.4 Supercharger controls must be located below or aft of the propeller controls.

5.2.5.5 Airplanes with tandem seating or single-place airplanes may utilize control locations on the left side of the cabin compartment; however, location order from left to right must be power (thrust) lever, propeller (rpm control), and mixture control.

5.2.6 Identical powerplant controls for each engine must be located to prevent confusion as to the engines they control.

5.2.6.1 Conventional multiengine powerplant controls must be located so that the left control(s) operates the left engine(s) and the right control(s) operates the right engine(s).

5.2.6.2 On twin-engine airplanes with front and rear engine locations (tandem), the left powerplant controls must operate the front engine and the right powerplant controls must operate the rear engine.

5.2.7 Wing flap and auxiliary lift device controls.

5.2.7.1 Wing flap and auxiliary lift device controls, if present, must be located centrally, or to the right of the pedestal or powerplant throttle control centerline.

5.2.7.2 Wing flap and auxiliary lift device controls, if present, must be located far enough away from the landing gear control to avoid confusion.

5.2.8 The landing gear control, if present, must be located to the left of the throttle centerline or pedestal centerline.

5.2.9 If nose/tail wheel steering is installed, it must be demonstrated that its use does not require exceptional pilot skill during takeoff and landing, in crosswinds, or in the event of an engine failure, or its use must be limited to low speed maneuvering.

5.2.10 Each fuel feed selector control, if present, must be located and arranged so that the pilot can see and reach it without moving any seat or primary flight control or requiring undue or disorienting head/body movement when his seat is at any position intended for use in flight.

5.2.10.1 For a mechanical fuel selector:

(1) The indication of the selected fuel valve position must be by means of a pointer and must provide positive identification and feel (detent, etc.) of the selected position.

(2) The position indicator pointer must be located at the part of the handle that is the maximum dimension of the handle measured from the center of rotation.

5.2.10.2 For electrical or electronic fuel selector:

(1) Digital controls or electrical switches must be properly labeled.

(2) Means must be provided to indicate to the flight crew the tank or function selected. Selector switch position is not acceptable as a means of indication. The “off” or “closed” position must be indicated in red.

5.2.10.3 If the fuel valve selector handle or electrical or digital selection is also a fuel shut-off selector, the off position marking must be colored red.

5.2.10.4 If there is a selector position other than “off” that does not provide adequate fuel flow for normal engine operation, these positions must be indicated in red and/or a red annunciation must be provided to the pilot.

5.2.10.5 If a separate emergency shut-off means is provided, it must be colored red.

5.2.11 Ignition Switches.

5.2.11.1 Ignition switches must control each ignition circuit on each engine.

5.2.11.2 Ignition switches must shut off each ignition circuit on each engine.

5.2.11.3 There must be means to quickly shut off all ignition on multiengine airplanes by the groupings of switches or by a master ignition control.

5.2.11.4 Each group of ignition switches, except ignition switches for turbine engines for which continuous ignition is not required, must have a means to prevent its inadvertent operation.

5.2.11.5 Each master ignition control must have a means to prevent its inadvertent operation.

5.2.12 If there are mixture controls, each mixture control must have guards or must be shaped and arranged to prevent confusion by feel with other controls.

5.2.12.1 The mixture controls must be grouped and arranged to allow:

- (1) Separate control of each engine, and
- (2) Simultaneous control of all engines.

5.2.13 Propeller Speed and Pitch Controls.

5.2.13.1 If there are propeller speed or pitch controls, they must be grouped and arranged to allow separate control of each propeller.

5.2.13.2 If there are propeller speed or pitch controls, they must be grouped and arranged to allow simultaneous control of all propellers.

5.2.13.3 The controls must allow ready synchronization of all propellers on multiengine airplanes.

5.3 *Motion and Effect of Cockpit Controls:*

5.3.1 Cockpit controls must be designed so that they operate in accordance with the following movement and actuation for powerplant and auxiliary controls:

(1) Powerplant Controls	Motion and effect
Power (thrust lever)	Forward to increase forward thrust and rearward to increase rearward thrust (Note: The intent of this does not preclude the use of stacked (or "piggy-back") thrust reverser levers).
Propellers	Forward to increase rpm.
Mixture	Forward or upward for rich.
Fuel	Forward for open.
Carburetor, air heat or alternate air	Forward or upward for cold.
Forced air induction systems	Forward, upward, or clockwise to increase pressure.
Rotary controls	Clockwise from off to full on.
(2) Auxiliary Controls	
Fuel tank selector	Right for right tanks, left for left tanks.
Landing gear	Down to extend.
Speed brakes, Spoilers	Aft to extend.

ASTM F3117/F3117M-18c

<https://standards.iteh.ai/catalog/standards/sist/7e88fdb1-8ceb-4fe4-a05e-9272a4b3a4aa/astm-f3117-f3117m-18c>

5.4 *Cockpit Control Knob Shape:*

5.4.1 Flap and landing gear control knobs must conform to the general shapes (but not necessarily the exact sizes or specific proportions) in Fig. 1.

5.4.2 Powerplant control knobs must conform to the general shapes (but not necessarily the exact sizes of specific proportions) in Fig. 2.

5.5 *Circuit Breakers and Fuses:*

5.5.1 If the ability to reset a circuit breaker is essential to safety in flight, the circuit breaker must be located so that it can be readily reset in flight.

5.5.2 If the ability to reset a circuit breaker is essential to safety in flight, the circuit breaker must be labeled as to its function so it can be readily reset in flight.

5.5.3 For fuses identified as replaceable in flight, the spare fuse(s) must be readily accessible to a required pilot.

5.5.4 If the ability to replace a fuse is essential to safety in flight, the fuse must be located so it can be readily replaced in flight.

5.5.5 If the ability to replace a fuse is essential to safety in flight, the fuse must be labelled so it can be readily replaced in flight.

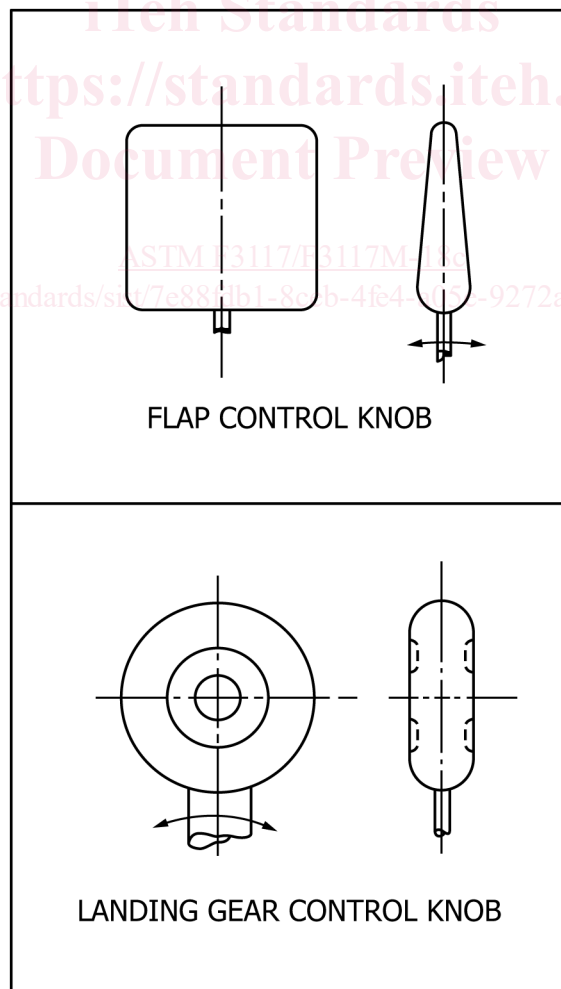

FIG. 1 Flap and Landing Gear Control Knobs

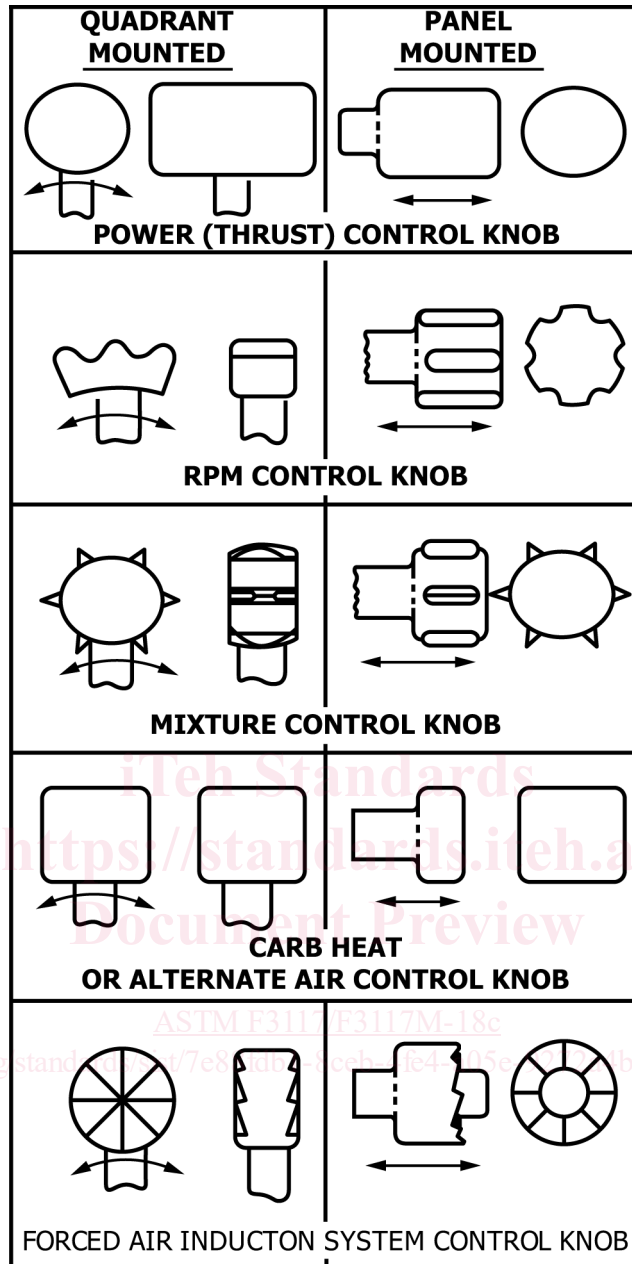

FIG. 2 Powerplant Control Knobs

5.6 Master Switch Arrangement:

5.6.1 If separate switches are incorporated into the master switch arrangement, a means must be provided for the switch arrangement to be operated by one hand with a single movement.

5.6.2 The master switch or its controls must be so installed that the switch is easily discernible and accessible to a crewmember.

5.7 Switches:

5.7.1 Each switch must be accessible to appropriate flight crew members.

5.7.2 Each switch must be labeled as to operation and the circuit controlled.

6. Flight Control Augmentation and Auto Flight System

6.1 Automatic Pilot Systems:

6.1.1 If an automatic pilot system is installed, unless there is automatic synchronization, there must be an indication to the pilot showing the alignment of the actuating device in relation to the control system it operates.

6.1.2 Automatic Pilot Controls.

6.1.2.1 If an automatic pilot system is installed, each manually operated control for the system operation must be readily accessible to the pilot.

6.1.2.2 If an automatic pilot system is installed, each control must operate in the same plane and sense of motion as specified in Section 5.1.3 for cockpit controls.

6.1.2.3 If an automatic pilot system is installed, the direction of motion must be plainly indicated on or near each control.

6.1.3 If an automatic pilot system is installed and can be coupled to airborne navigation equipment, there must be an indication to the flight crew showing the current mode of operation. Selector switch position is not acceptable as a means of indication.

## 7. Displays – General

### 7.1 *Instrument Arrangement and Visibility:*

7.1.1 Each flight, navigation, and powerplant instrument for use by any required pilot during takeoff, initial climb, final approach, and landing must be located so that any pilot seated at the controls can monitor the aircraft's flight path and these instruments with minimum head and eye movement.

7.1.1.1 The powerplant instruments for these flight conditions are those needed to set power within powerplant limitations.

7.1.2 For each aircraft, the flight instruments required by Flight and Navigation Instruments in Specification F3061/F3061M, and, as applicable, by the operating rules of the applicable Civil Aviation Authority (CAA), must be grouped on the instrument panel and centered as nearly as practicable about the vertical plane of each required pilot's forward vision.

7.1.2.1 The instrument that most effectively indicates the attitude must be on the panel in the top center position.

7.1.2.2 The instrument that most effectively indicates airspeed must be adjacent to and directly to the left of the instrument in the top center position.

7.1.2.3 The instrument that most effectively indicates altitude must be adjacent to and directly to the right of the instrument in the top center position.

7.1.2.4 The instrument that most effectively indicates direction of flight, other than the magnetic direction indicator required by Flight and Navigation Instruments in Specification F3061/F3061M, must be adjacent to and directly below the instrument in the top center position.

7.1.3 Electronic display indicators may be used for compliance with Flight and Navigation Instruments in Specification F3061/F3061M, when such displays comply with requirements in 8.1 and Electronic Display Instrument Systems in Specification F3061/F3061M.

7.1.4 For each multiengine airplane, identical powerplant instruments must be located so as to prevent confusion as to which engine each instrument relates.

7.1.5 If a visual indicator is provided to indicate malfunction of an instrument, it must be effective under all probable cockpit lighting conditions.

### 7.2 *Instrument Lights:*

7.2.1 A cabin dome light is not considered an instrument light.

NOTE 2—The purpose of instrument lights is to allow the flight crew to see, locate, and identify information on displays and/or interact with controls under all lighting conditions. A cabin dome light intended to light the inside of the cabin is not considered an instrument light. However, an instrument light can be designed such that it also lights the inside of the cabin. Lights designed this way can be considered instrument lights.

7.2.2 The instrument lights must make each instrument and control easily readable and discernible.

7.2.3 The instrument lights must be installed so that their direct rays, and rays reflected from the windshield or other surface, are shielded from the pilot's eyes.

## 8. Primary Flight Information Displays

### 8.1 *Electronic Display Instrument Systems:*

8.1.1 Electronic display indicators, including those with features that make isolation and independence between powerplant instrument systems impractical, must be easily legible under all lighting conditions encountered in the cockpit, including direct sunlight, considering the expected electronic display brightness level at the end of an electronic display indicator's useful life.

8.1.1.1 Specific limitations on display system useful life must be contained in the Instructions for Continued Airworthiness required by 12.1.

8.1.2 Electronic display indicators, including those with features that make isolation and independence between powerplant instrument systems impractical, must incorporate equivalent visual displays of the instrument markings required by 13.2 through 13.7, or visual displays that alert the pilot to abnormal operational values or approaches to established limitation values, for each parameter required to be displayed.

## 9. Primary Flight Guidance

9.1 *Flight Director Systems*—If a flight director system is installed, means must be provided to indicate to the flight crew its current mode of operation. Selector switch position is not acceptable as a means of indication.



## 10. Communication and Audio Systems

### 10.1 *Electronic Communication Equipment:*

10.1.1 For those airplanes required to have more than one flightcrew member, or whose operation will require more than one flightcrew member, the cockpit must be evaluated to determine if the flightcrew members, when seated at their duty station, can converse without difficulty under the actual cockpit noise conditions when the airplane is being operated.

10.1.2 If the airplane design includes provision for the use of communication headsets, the evaluation must also consider conditions where headsets are being used.

10.1.3 If the evaluation shows conditions under which it will be difficult to converse, an intercommunication system must be provided.

## 11. Alerts

### 11.1 *Pilot Alerts:*

11.1.1 Information concerning an unsafe system operating condition must be provided in a timely manner to the crew to enable them to take appropriate corrective action.

11.1.1.1 The information required by 11.1.1 must be presented as an appropriate alert if immediate pilot awareness and immediate or subsequent corrective action is required.

11.1.1.2 The assessment discussed in System Safety Requirements in Specification F3061/F3061M must be used to determine what failure conditions would become “unsafe system operating conditions” if the crew failed to take any action or observe appropriate precautions. Refer to terminology in Specification F3061/F3061M.

11.1.1.3 For purposes of this requirement, an alert is considered appropriate if it can be shown to effectively alert the flight crew to the potential unsafe system operating condition in a timely fashion. The particular method of indication would depend on the urgency and need for flight crew awareness or action that is necessary for that particular failure. Inherent aircraft and/or system characteristics may be used in lieu of dedicated indications and annunciations if they can be shown to be timely and effective.

11.1.1.4 Even if aircraft operation or performance is unaffected or insignificantly affected at the time of failure, flight crew notification is required if it is considered necessary for the flight crew to take any action or observe any precautions.

11.1.1.5 If aircraft operation or performance is unaffected or insignificantly affected, information and alerting notifications may be inhibited during specific phases of flight where informing the crew is considered more hazardous than not informing them.

11.1.2 Systems and controls, including indications and annunciations, must be designed to minimize crew errors which could create additional hazards.

11.1.3 If provisions for the use of communication headsets are provided, it must be demonstrated that the flightcrew members will receive all required aural alerts under the actual cockpit noise conditions when the aircraft is being operated when any headset is being used.

NOTE 3—All aural alerts need to be evaluated with and without headsets to assess their effectiveness and acceptability under all ambient noise conditions that may be encountered in the operational environment. There have been problems created by using active noise reduction headsets in older cockpits that have an alert sounded only in the cabin and not in the cockpit. The aircraft evaluations should also include the examination of an active noise reduction (ANR) system if it is going to be used on the airplane. Regardless of the method chosen to present auditory alerts, they should be easily detected and quickly understood in all ambient noise conditions.

### 11.2 *Warning, Caution, and Advisory Lights or Indicators:*

11.2.1 If warning, caution, or advisory lights are installed in the cockpit, they must, unless otherwise approved by the Certifying Authority, meet the requirements of 11.2.1.1 through 11.2.1.6.

11.2.1.1 Warning lights (lights indicating a hazard which may require immediate corrective action) must be red.

11.2.1.2 Caution lights (lights indicating the possible need for future corrective action) must be yellow/amber.

11.2.1.3 Safe operation lights must be green.

11.2.1.4 Lights not described in 11.2.1.1 through 11.2.1.3 may be any other color, including white, provided the color differs sufficiently from the colors prescribed in 11.2.1.1 through 11.2.1.3 to avoid possible confusion.

11.2.1.5 Colors used per 11.2.1.4 should be consistently applied so as not create confusion with that color used elsewhere in the flight deck.

11.2.1.6 All warning, caution, or advisory indications must be effective under all probable cockpit lighting conditions.

## 12. Continued Airworthiness and Maintenance

### 12.1 *Instructions for Continued Airworthiness:*

12.1.1 The applicant must prepare Instructions for Continued Airworthiness in accordance with 12.1.2 through 12.1.9 that are acceptable to the Certifying Authority.

NOTE 4—The instructions may be incomplete at type certification if a program exists to ensure their completion prior to delivery of the first airplane or issuance of a standard certificate of airworthiness, whichever occurs later.

12.1.2 The Instructions for Continued Airworthiness for each airplane must include the Instructions for Continued Airworthiness for each engine and propeller (hereinafter designated ‘products’), for each appliance required by this chapter, and any required information relating to the interface of those appliances and products with the airplane.

12.1.3 If Instructions for Continued Airworthiness are not supplied by the manufacturer of an appliance or product installed in the airplane, the Instructions for Continued Airworthiness for the airplane must include the information essential to the continued airworthiness of the airplane.

12.1.4 The applicant must prepare a program to show how changes to the Instructions for Continued Airworthiness made by the applicant or by the manufacturers of products and appliances installed in the airplane will be distributed.

12.1.5 The Instructions for Continued Airworthiness must be in the form of a manual or manuals as appropriate for the quantity of data to be provided.

12.1.6 The format of the manual or manuals must provide for a practical arrangement.

12.1.7 The contents of the manual or manuals must be prepared in the English language or other language acceptable to the Certifying Authority.

12.1.8 The Instructions for Continued Airworthiness must contain the following manuals or sections, as appropriate, and information:

12.1.8.1 Airplane maintenance manual or section.

(1) Introduction information that includes an explanation of the airplane's features and data to the extent necessary for maintenance or preventive maintenance.

(2) A description of the airplane and its systems and installations including its engines, propellers, and appliances.

(3) Basic control and operation information describing how the airplane components and systems are controlled and how they operate, including any special procedures and limitations that apply.

(4) Servicing information that covers details regarding servicing points, capacities of tanks, reservoirs, types of fluids to be used, pressures applicable to the various systems, location of access panels for inspection and servicing, locations of lubrication points, lubricants to be used, equipment required for servicing, tow instructions and limitations, mooring, jacking, and leveling information.

12.1.8.2 Maintenance Instructions.

(1) Scheduling information for each part of the airplane and its engines, auxiliary power units, propellers, accessories, instruments, and equipment that provides the recommended periods at which they should be cleaned, inspected, adjusted, tested, and lubricated, and the degree of inspection, the applicable wear tolerances, and work recommended at these periods. However, the applicant may refer to an accessory, instrument, or equipment manufacturer as the source of this information if the applicant shows that the item has an exceptionally high degree of complexity requiring specialized maintenance techniques, test equipment, or expertise. The recommended overhaul periods and necessary cross reference to the Airworthiness Limitations section of the manual must also be included. In addition, the applicant must include an inspection program that includes the frequency and extent of the inspections necessary to provide for the continued airworthiness of the airplane.

(2) Troubleshooting information describing probable malfunctions, how to recognize those malfunctions, and the remedial action for those malfunctions.

(3) Information describing the order and method of removing and replacing products and parts with any necessary precautions to be taken.

(4) Other general procedural instructions including procedures for system testing during ground running, symmetry checks, weighing and determining the center of gravity, lifting and shoring, and storage limitations.

12.1.8.3 Diagrams of structural access plates and information needed to gain access for inspections when access plates are not provided.

12.1.8.4 Details for the application of special inspection techniques including radiographic and ultrasonic testing where such processes are specified.

12.1.8.5 Information needed to apply protective treatments to the structure after inspection.

12.1.8.6 All data relative to structural fasteners such as identification, discard recommendations, and torque values.

12.1.8.7 A list of special tools needed.

12.1.8.8 In addition, for Level 4 airplanes, the following information must be furnished:

(1) Electrical loads applicable to the various systems;

(2) Methods of balancing control surfaces;

(3) Identification of primary and secondary structures; and

(4) Special repair methods applicable to the airplane.

12.1.9 The Instructions for Continued Airworthiness must contain a section titled Airworthiness Limitations that is segregated and clearly distinguishable from the rest of the document.

12.1.9.1 This Airworthiness Limitations must set forth each mandatory replacement time, structural inspection interval, and related structural inspection procedure required for type certification.

12.1.9.2 If the Instructions for Continued Airworthiness consist of multiple documents, the Airworthiness Limitations must be included in the principal manual.

12.1.9.3 The Airworthiness Limitations must contain a legible statement in a prominent location that reads: "The Airworthiness Limitations is approved by the applicable Civil Aviation Authority (CAA), and specifies maintenance required under the governing