



Designation: C1113/C1113M – 09 (Reapproved 2019)

Standard Test Method for Thermal Conductivity of Refractories by Hot Wire (Platinum Resistance Thermometer Technique)¹

This standard is issued under the fixed designation C1113/C1113M; the number immediately following the designation indicates the year of original adoption or, in the case of revision, the year of last revision. A number in parentheses indicates the year of last reapproval. A superscript epsilon (ϵ) indicates an editorial change since the last revision or reapproval.

1. Scope

1.1 This test method covers the determination of thermal conductivity of non-carbonaceous, dielectric refractories.

1.2 Applicable refractories include refractory brick, refractory castables, plastic refractories, ramming mixes, powdered materials, granular materials, and refractory fibers.

1.3 Thermal conductivity k -values can be determined from room temperature to 1500 °C [2732 °F], or the maximum service limit of the refractory, or to the temperature at which the refractory is no longer dielectric.

1.4 This test method is applicable to refractories with k -values less than 15 W/m·K [100 Btu·in./h·ft²·°F].

1.5 In general it is difficult to make accurate measurements of anisotropic materials, particularly those containing fibers, and the use of this test method for such materials should be agreed between the parties concerned.

1.6 *Units*—The values stated in either SI units or inch-pound units are to be regarded separately as standard. The values stated in each system may not be exact equivalents; therefore, each system shall be used independently of the other. Combining values from the two systems may result in nonconformance with the standard.

1.7 *This standard does not purport to address all of the safety concerns, if any, associated with its use. It is the responsibility of the user of this standard to establish appropriate safety, health, and environmental practices and determine the applicability of regulatory limitations prior to use.*

1.8 *This international standard was developed in accordance with internationally recognized principles on standardization established in the Decision on Principles for the Development of International Standards, Guides and Recommendations issued by the World Trade Organization Technical Barriers to Trade (TBT) Committee.*

¹ This test method is under the jurisdiction of ASTM Committee C08 on Refractories and is the direct responsibility of Subcommittee C08.02 on Thermal Properties.

Current edition approved Jan. 1, 2019. Published January 2019. Originally approved in 1990. Last previous edition approved in 2013 as C1113/C1113M – 09 (2013). DOI: 10.1520/C1113_C1113M-09R19.

2. Referenced Documents

2.1 *ASTM Standards*:²

C134 Test Methods for Size, Dimensional Measurements, and Bulk Density of Refractory Brick and Insulating Firebrick

C201 Test Method for Thermal Conductivity of Refractories

C865 Practice for Firing Refractory Concrete Specimens

E691 Practice for Conducting an Interlaboratory Study to Determine the Precision of a Test Method

2.2 *ISO Standard*:³

DIS*8894-2 Refractory Materials - Determination of Thermal Conductivity up to 1250 °C of Dense and Insulating Refractory Products According to the Hot Wire Parallel Method

3. Terminology

3.1 *Symbols*:

3.1.1 R_T —hot wire resistance at any temperature, ohms.

3.1.2 R_0 —hot wire resistance at 0 °C [32 °F] (from an ice bath), ohms.)

3.1.3 L —hot wire length, cm.

3.1.4 T —sample test temperature, °C.

3.1.5 V —average voltage drop across hot wire, volts.

3.1.6 V_s —average voltage drop across standard resistor, volts.

3.1.7 R_s —average resistance of standard resistor, ohms.

3.1.8 I —average current through hot wire (V_s/R_s), amperes.

3.1.9 Q —average power input to hot wire (I^2V^*100/L) during test, watts/m.

3.1.10 t —time, min.

3.1.11 B —slope of linear region in R_T versus $\ln(t)$ plot.

3.1.12 k —thermal conductivity, W/m·K.

² For referenced ASTM standards, visit the ASTM website, www.astm.org, or contact ASTM Customer Service at service@astm.org. For *Annual Book of ASTM Standards* volume information, refer to the standard's Document Summary page on the ASTM website.

³ Available from American National Standards Institute (ANSI), 25 W. 43rd St., 4th Floor, New York, NY 10036, http://www.ansi.org.

3.1.13 *a*, *b*, *c*—coefficients of a second-degree polynomial equation relating hot wire resistance and temperature.

3.1.14 *V*, *I*, and *Q* are preferably measured in the linear region of the R_T versus $\ln(t)$ plot for maximum data accuracy.

4. Summary of Test Method

4.1 A constant electrical current is applied to a pure platinum wire placed between two brick. The rate at which the wire heats is dependent upon how rapidly heat flows from the wire into the constant-temperature mass of the refractory brick. The rate of temperature increase of the platinum wire is accurately determined by measuring its increase in resistance in the same way a platinum resistance thermometer is used. A Fourier equation is used to calculate the *k*-value based on the rate of temperature increase of the wire and power input.⁴

5. Significance and Use

5.1 The *k*-values determined at one or more temperatures can be used for ranking products in relative order of their thermal conductivities.

5.2 Estimates of heat flow, interface temperatures, and cold face temperatures of single and multi-component linings can be calculated using *k*-values obtained over a wide temperature range.

5.3 The *k*-values determined are “at temperature” measurements rather than “mean temperature” measurements. Thus, a wide range of temperatures can be measured, and the results are not averaged over the large thermal gradient inherent in water-cooled calorimeters.

5.4 The *k*-values measured are the combination of the *k*-values for the width and thickness of the sample, as the heat flow from the hot wire is in both of those directions. The water-cooled calorimeter measures *k*-value in one direction, through the sample thickness.

5.5 The test method used should be specified when reporting *k*-values, as the results obtained may vary with the type of test method that is used. Data obtained by the hot wire method are typically 10 to 30 % higher than data obtained by the water calorimeter method given in Test Method C201.

6. Apparatus

6.1 A block diagram of a suggested test apparatus is shown in Fig. 1. Details of the equipment are as follows:

6.1.1 *Furnace*, with a heating chamber capable of supporting two 228-mm [9-in.] straight brick. The furnace temperature may be controlled with a set point controller adjusted manually between test temperatures, with a programmable controller, or with the computer. If a programmable controller is used, and the hot wire power is applied by computer, the furnace temperature program must be synchronized with the computer program used to collect the test data. The furnace temperature should be accurate to $\pm 5^\circ\text{C}$ [9°F] and controlled to within a $\pm 1^\circ\text{C}$ [1.8°F] precision such that the temperature variation

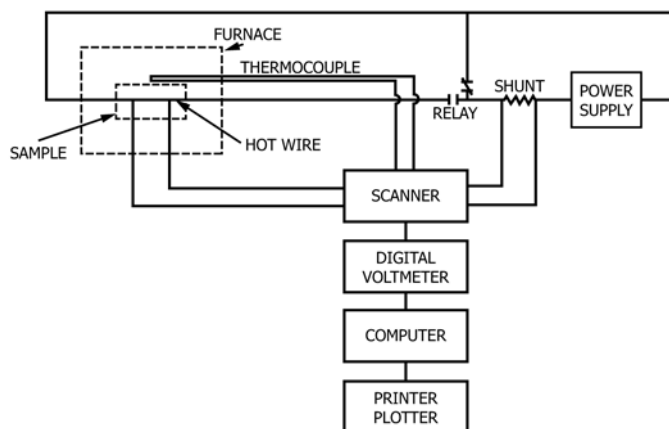

FIG. 1 Diagram of Apparatus

with time is minimized. Temperature stability measurements are not required by this test method because small temperature variations with time are difficult to measure and dependent on thermocouple placement (in air, a protection tube, or in the sample). However, if sample temperature measurements are averaged during a 30-min period after furnace equilibration (prior to a hot wire test), the maximum-minimum difference should preferably be less than 1°C [1.8°F]. In addition, if a linear regression analysis is done on the average temperature versus time data, the rate of temperature change should preferably be less than 0.05°C [0.09°F]/min. Four holes with alumina protection tubes shall be provided in the kiln wall for the platinum voltage and current leads. These holes should be widely spaced to minimize electrical conductivity at elevated temperatures.

6.1.2 *Thermocouple*, to measure sample temperature.

6.1.3 *Programmable Power Supply*, capable of constant current control in the range from 0 to 10 A (0 to 50 V). During a 10-min test period, stability should be ± 0.002 A. Size the power supply according to the anticipated wire harnesses diameter and type of materials to be tested. A high (5 to 10 A) ampere supply is suggested for large-diameter wire and/or testing of high conductivity materials. However, lower ampere supplies will give better current control for low currents used for low conductivity materials or with a smaller diameter wire harness.

6.1.4 *Shunt*, with a resistance of $0.1\ \Omega$ rated at 15 A.

6.1.5 *Programmable Scanner*, capable of directing several different voltage inputs to the digital voltmeter. It is also used to activate a relay to turn on and off the test circuit.

6.1.6 *Relay*, with a current rating of 25 A at 24 V.

6.1.7 *Programmable Digital Voltmeter*, with auto ranging, auto calibration, and $6\frac{1}{2}$ digit resolution.

6.1.8 *Computer*, capable of controlling the operation of the power supply, scanner, and digital voltmeter. It must also be able to collect and analyze the test results. Commercially available data acquisition (with an IEEE device and sequential file numbering capability) and analysis (spreadsheet with macro capability) software is acceptable; custom software is not necessary.

6.1.9 *Printer/Plotter*, capable of documenting the raw data and various calculated values. The plotter function is used to

⁴ Morrow, G. D., “Improved Hot Wire Thermal Conductivity Technique,” *Bulletin of the American Ceramic Society*, Vol 58, No. 7, 1979, pp.687–90.

plot the resistance versus \ln (time) relationship. This is used to visually determine if a linear relationship was obtained and the location of the linear region.

6.2 *Reusable Test Harness*, consisting of a straight section at least 30 cm [11.8 in.] long with two perpendicular voltage leads about 15 cm [5.9 in.] apart near the center per Fig. 2. To avoid thermocouple effect voltage errors, use pure platinum wire for the test harness and for the entire length of voltage leads. Platinum alloy wire may be used only for current leads from outside the furnace to the test harness section itself. The platinum voltage lead wires may be taken to an insulated terminal box on the side of the furnace for connection to lower temperature lead wires, or run all the way back to the digital voltmeter terminals. The main part of the harness wire shall be between 0.330 and 0.508 mm [0.013 and 0.020 in.] in diameter. The voltage leads may be the same size as the main harness wire, although it is recommended that they be 0.330 mm [0.013 in.] or smaller such that their area is less than half that of the main wire. The current leads up to the main harness shall be at least the same size as the main harness wire. The main harness may be fabricated by butt welding voltage leads to a solid main wire using a micro torch or arc percussion welder, or by arc welding the wires into a bead. If beads are made by arc welding, keep the bead size as small as possible, and carefully straighten out the bead to form a tee joint with the voltage lead perpendicular to the main wire.

7. Sampling and Specimen Preparation

7.1 The test specimens consist of two 228-mm [9-in.] straight brick or equivalent. Select these specimens for uniformity of structure and bulk density. Bulk density should be determined in accordance with Test Methods C134.

7.2 The hot wire harness is positioned near the center of the two brick-shaped specimens and in intimate contact with both, either by using samples with a step diamond ground into the mating surface, by forming the sample around the harness, or by deformation of soft samples. See Fig. 2 for a schematic of how the steps provide intimate lateral contact with both halves of the sample assembly.

7.2.1 *Refractory Brick*—The steps cut in the brick shall have a maximum depth of 0.8 mm [0.032 in.], although lesser depths can be used for wires smaller than the 0.508-mm [0.020-in.] maximum wire size. To ensure that samples do not rock, the average depth of both steps shall be within 0.1 mm [0.004 in.] of each other. In addition, the mating surfaces shall be flat to less than 0.1 mm [0.004 in.] as determined by the following procedure. After the steps are ground, the bricks shall be placed together with the steps touching each other to check for any noticeable rock or movement between the two bricks; no visible movement is acceptable. Rock is most often caused by the use of a grinding wheel which has a high spot in the center, causing a smaller step depth close to the step than across the rest of the mating surface. Dressing the wheel so that it is flat or that the side which forms the step edge is high will normally provide acceptable results. After the step height and mating surfaces are acceptable, voltage lead grooves shall be cut across the high part of the step in one of the samples. To accommodate the weld beads at the junctions of the main wire and voltage leads, it is permissible to chip out small cavities in the brick at these locations using a hammer and center punch.

7.2.2 *Refractory Castables*—Refractory castables specimens can be cut into brick shapes and prepared as in 7.2.1 or a special castable mold with the 0.8-mm [0.032-in.] step can be used to form the brick shapes. Two thin grooves must be cut for the perpendicular voltage leads in one of the brick. The hot wire harness can also be cast in place for a single usage.

7.2.3 *Plastic Refractories and Ramming Mixes*—Immediately after forming, press the hot wire harness between two 228-mm [9-in.] straight bricks. Pressure should be applied during drying to keep the brick in very close contact.

7.2.4 *Low-Strength Materials*—Use a sharp knife to scribe grooves into one of the brick into which the hot wire harness will be pressed.

7.2.5 *Compressible Refractory Fiber Blankets*—Fabricate a weighted cover to compress and hold the samples to the desired thickness (and bulk density) during testing. A cover and side spacers are required.

7.2.6 *Powdered or Granular Materials*—A refractory container must be fabricated to contain powdered or granular materials. The container may be of two parts, each the size of a 228-mm [9-in.] straight brick. The lower part will have four sides and a bottom. The upper part will have four sides only. Alternatively, a container of one part only may be used. The one-part container will have the volume of two 228-mm [9-in.] brick. Record the weight and interior volume for use in calculating the apparent bulk density of the test material.

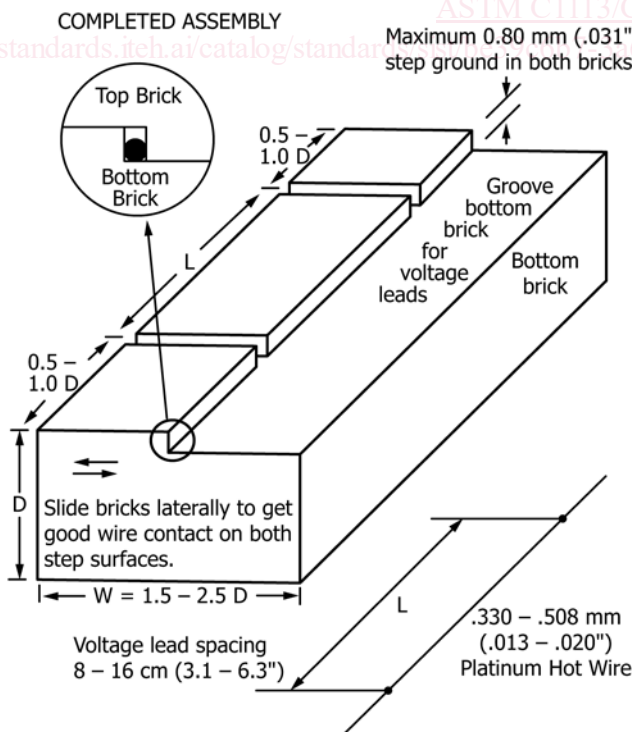

FIG. 2 Hot Wire Sample Setup