



Designation: D5397 – 19

Standard Test Method for Evaluation of Stress Crack Resistance of Polyolefin Geomembranes Using Notched Constant Tensile Load Test¹

This standard is issued under the fixed designation D5397; the number immediately following the designation indicates the year of original adoption or, in the case of revision, the year of last revision. A number in parentheses indicates the year of last reapproval. A superscript epsilon (ϵ) indicates an editorial change since the last revision or reapproval.

1. Scope

1.1 This test method is used to develop test data from which the susceptibility of polyolefin geomembrane sheet material to stress cracking under a constant tensile load condition and an accelerated environmental condition can be evaluated.

1.2 This test method measures the failure time associated with a given test specimen at a specified tensile load level. Results from a series of such tests utilizing a range of load levels can be used to construct a stress-time plot on a log-log axis.

1.3 The values stated in SI units are to be regarded as the standard. The inch-pound units given in parentheses are provided for information only.

1.4 *This standard does not purport to address all of the safety concerns, if any, associated with its use. It is the responsibility of the user of this standard to establish appropriate safety, health, and environmental practices and determine the applicability of regulatory limitations prior to use.*

1.5 *This international standard was developed in accordance with internationally recognized principles on standardization established in the Decision on Principles for the Development of International Standards, Guides and Recommendations issued by the World Trade Organization Technical Barriers to Trade (TBT) Committee.*

2. Referenced Documents

2.1 ASTM Standards:²

D883 Terminology Relating to Plastics

D4354 Practice for Sampling of Geosynthetics and Rolled Erosion Control Products (RECPs) for Testing

D4439 Terminology for Geosynthetics

D4703 Practice for Compression Molding Thermoplastic Materials into Test Specimens, Plaques, or Sheets

D5199 Test Method for Measuring the Nominal Thickness of Geosynthetics

D6693/D6693M Test Method for Determining Tensile Properties of Nonreinforced Polyethylene and Nonreinforced Flexible Polypropylene Geomembranes

3. Terminology

3.1 Definitions:

3.1.1 *actual thickness, n*—individual measurement per Test Method D5199, on a specimen tab.

3.1.2 *average thickness, n*—result of Test Method D5199 testing, that is, average of ten specimens.

3.1.3 *geomembrane, n*—very low permeability synthetic membrane liners or barriers used with any geotechnical engineering-related material so as to control fluid migration in a man-made project, structure, or system.

3.1.4 *ligament, n*—the portion of geomembrane that remains uncut under the notch.

3.1.5 *ligament thickness, n*—length of the ligament measured from the bottom of the notch to the edge of the specimen in a direction perpendicular to the plane of the test specimen.

3.1.6 *multi-component geomembrane, n*—a geomembrane that includes multiple layers of different nature.

3.1.7 *nominal thickness, n*—the thickness specified without regard of tolerance.

3.1.8 *notch, n*—cut made using a specified tool in prescribed conditions.

3.1.9 *slow crack growth, n*—type of fracture mechanism characterized by the stable growth of a crack with little deformation in the material.

3.1.10 *smooth geomembrane, n*—a geomembrane that does not present any surface texture.

3.1.10.1 *Discussion*—A geomembrane can be smooth on one side but textured on the other side.

3.1.11 *stress crack, n*—an external or internal crack in a plastic caused by tensile stresses less than its short-time mechanical strength (see Terminology D883).

3.1.11.1 *Discussion*—The development of such cracks is

¹ This test method is under the jurisdiction of ASTM Committee D35 on Geosynthetics and is the direct responsibility of Subcommittee D35.02 on Endurance Properties.

Current edition approved Jan. 1, 2019. Published January 2019. Originally approved in 1993. Last previous edition approved in 2012 as D5397 – 07 (2012). DOI: 10.1520/D5397-19.

² For referenced ASTM standards, visit the ASTM website, www.astm.org, or contact ASTM Customer Service at service@astm.org. For *Annual Book of ASTM Standards* volume information, refer to the standard's Document Summary page on the ASTM website.

frequently accelerated by the environment to which the plastic is exposed. The stresses that cause cracking may be present internally or externally or may be combinations of these stresses.

3.2 For definitions of other terms relating to geotextiles and geomembranes used in this standard, refer to Terminology D4439.

4. Summary of Test Method

4.1 This test method consists of subjecting a dumbbell-shaped notched test specimen from a polyolefin sheet to a constant tensile load in the presence of a surface-active agent and at an elevated temperature. The time to failure of the test specimen is recorded. The results of a series of such tests conducted at different stress levels are presented by plotting stress level against failure time for each stress level on a log-log axis.

5. Significance and Use

5.1 This test method does not purport to interpret the resulting response curve. Such interpretation is left to the parties involved in the commissioning and reporting of the test results.

5.2 This test method is intended as an index test and may be used for grading polyolefin geomembrane sheets in regard to their stress-cracking sensitivity.

5.2.1 Conditions that can affect stress cracking include: level of loading, test temperature and environment, microstructure, polymer additive package, processing history, and thermal history.

5.3 The test method is applicable to smooth, homogeneous polyolefin geomembranes where the two sides are parallel to permit application of the stress on a well-defined surface delimited by the surface of the geomembrane on one side, and the bottom of the notch on the other side.

5.4 The test is applicable to textured geomembranes when prepared as described in 8.3.2.

5.5 The test may be applicable to multi-component geomembranes (such as white, conductive, or other non-homogeneous sheets) or limited to the evaluation of the base polymer when prepared as described in 8.3.3.

5.6 The test is not applicable to bituminous, EPDM, plasticized PVC, and other non-polyolefin geomembranes, as these materials are not susceptible to slow crack growth.

5.7 This test method may not be applied to polyolefin geomembranes that do not exhibit a well-defined yield point, such as some VLDPE and LLDPE.

6. Apparatus

6.1 *Blanking Die*—A die suitable for cutting test specimens to the dimensions and tolerances shown in Fig. 1.

NOTE 1—The length of the specimen can be changed to suit the design of the test apparatus. However, there should be a constant neck section with length at least 12.7 mm (0.5 in.) long. The width should be 3.20 mm (0.125 in.) \pm 0.025 mm.

6.2 *Notching Device*—A device or machine that can produce a consistent notch depth.

NOTE 2—An evaluation of the notching technique can be performed by quenching a notched specimen in liquid nitrogen and then fracturing it. The notch depth can readily be measured by examining the fracture surface under a reflected light microscope. Other methods of verifying notch depth include viewing the cut specimen on its side in a microscope with the aid of a eyepiece micrometer or a calibrated reticle.

6.3 *Blade*—A single-edged razor made of carbon steel. The tip profile is that of an arrow rather than that of a chisel point. The sharpness of the point is critical to the cleanliness of the cut, which affects the results of the test significantly.

6.4 *Stress-Cracking Apparatus*—Equipment suitable for subjecting test specimens to a tensile stress of up to 13.8 MPa (2000 lb/in.²). The specimens shall be maintained at a constant temperature of 50 \pm 1 °C (122 \pm 2 °F) while being totally immersed in a surface-active agent. The solution should be constantly agitated to provide a uniform concentration throughout the bath.

NOTE 3—The apparatus shown in Fig. 2 is one type that has been used and is capable of testing up to 20 specimens at a time. This equipment uses a lever system with a mechanical advantage (MA) of three to impose the desired loading on each specimen. The surface-active agent in which the specimens are immersed is contained in an open stainless steel tank. A submersion heater and controller are used to maintain the test temperature. A pump keeps the liquid in a constant state of agitation. A timing clock for each test specimen is also provided to record automatically the failure time of the test specimens to the nearest 0.1 h.

NOTE 4—If “on/off” switches are used to control the timing clock, the

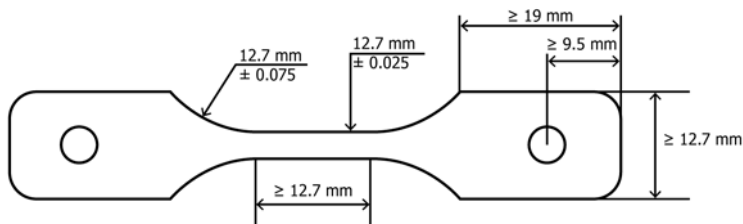

NOTE 1—Dimensions in millimetres to an accuracy of 0.025 mm unless otherwise indicated.

FIG. 1 Dimensions of Test Specimens

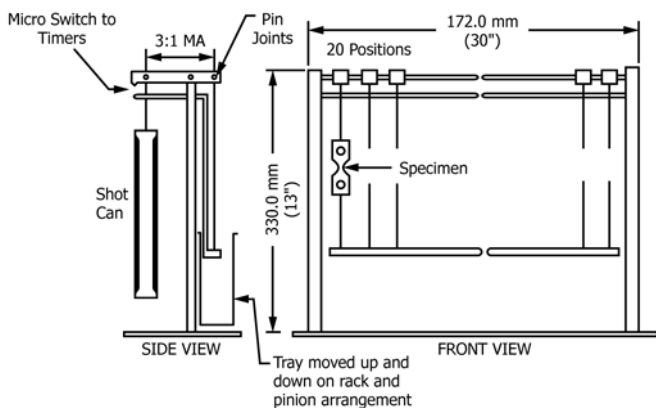

NOTE 1—The number of positions in the test frame is optional.

FIG. 2 Constant Stress Loading Apparatus Consisting of 20 Specimen Test Positions

switch must be sensitive enough to be turned off under 200 g of the force.

7. Reagent

7.1 The reagent should consist of 10 % surface-active agent with 90 % deionized water. The surface-active agent is Igepal CO-630³ that is nonylphenoxy poly(ethyleneoxy)ethanol. The reagent should be stored in a closed container. The reagent in the bath should be replaced every two weeks to maintain a constant concentration.

NOTE 5—The pH of the reagent may also be monitored throughout the duration of the test, and the solution replaced when a change in pH is detected. Without evidence of the chemical stability of the solution, the solution must be replaced every two weeks.

NOTE 6—Other incubation solutions may also be used in the test, provided that the parties involved mutually agree to the changes and state the specific details in the final report.

8. Sampling

8.1 *Lot Sample*—Divide the product into lots and take the lot sample as directed in Practice D4354.

8.2 *Laboratory Sample*—As a laboratory sample for acceptance testing, take a full-width swatch approximately 1 m (40 in.) long in the machine direction from each roll in the lot sample. The sample may be taken from the end portion of a roll, provided there is no evidence it is distorted or different from other portions of the roll.

8.3 *Selection of the Location Where to Cut the Specimens:*

8.3.1 For smooth geomembranes manufactured with a single polymer formulation, proceed to 8.4.

8.3.2 For textured geomembranes manufactured with a single polymer formulation in all layers, test the smooth edges if available. If the membrane does not have smooth edges, prepare a plaque according to Practice D4703, Procedure C. Proceed to 8.4, considering this plaque as the laboratory sample. Report that the sample was tested as a plaque in addition to the other reporting requirements.

NOTE 7—Results obtained on a sample prepared from the actual

³ Igepal CO-630 may be obtained from Rhone-Poulenc, CN 7500, Prospect Plains Road, Cranbury, NJ 08512-7500.

geomembrane sheet (that is, as per 8.3.1) may differ from those obtained on the same sample, but using specimens cut out from a plaque prepared using Practice D4703, Procedure C (that is, as per 8.3.2). Caution is required when analyzing the results and comparing products.

8.3.3 For other types of geomembrane, refer to Appendix X2 for specific guidance.

8.4 *Test Specimens*—At least 30 test specimens are cut from each swatch in the laboratory sample. For each set of tests, all specimens must be taken from one direction.

NOTE 8—If not specified, the cross-machine direction shall be tested. When testing the cross direction, specimens are oriented in that direction. Hence the notch is placed in the machine direction so that the specimens are stressed in the desired cross-machine direction.

NOTE 9—It has been found that inserting a grommet or eyelet in the two holes at the end tabs of the test specimen helps to reduce the number of “grip failures” or failures occurring outside of the neck section of the specimen.

9. Procedure

9.1 Measure the thickness per Test Method D5199 of each individual test specimen at its minimum cross section to the nearest 0.025 mm (0.001 in.). The variation in thickness should not be greater than $\pm 5\%$ of the average thickness of the laboratory sample of geomembrane.

9.2 Cut into each specimen a control imperfection (notch) on one surface as shown in Fig. 3. The depth of the notch should produce a ligament thickness of $80\% \pm 1\%$ of the nominal thickness of the laboratory sample.

NOTE 10—Using this procedure, the actual notch depth will vary in accordance with the actual thickness of the test specimen. For example, a sheet of nominal thickness of 2 mm (80 mil) might have thicknesses ranging from 1.98 to 2.08 mm (78 to 82 mil). To obtain a constant ligament thickness of 1.62 mm (64 mil), the notch depth would vary from 0.36 to 0.46 mm (14 to 18 mil), depending upon the actual thickness of the individual test specimens.

9.3 Inspect the edge of the blade for scratches and burrs under normal vision prior to the cut. No single blade shall be used for notching more than 20 test specimens.

9.4 Test specimens are loaded at various percentages of their yield stress, measured per Test Method D6693/D6693M. The applied stress levels should range from approximately 20 to 65 % at maximum increments of 5 %. Three specimens are tested at each stress level to produce statistically significant results.

NOTE 11—To develop the entire curve in a single direction at the recommended values listed above will require ten increments at three specimens each, or 30 individual tests. If both directions are to be challenged, the entire test will require twice as many test specimens.

9.5 For each set of specimens tested, the yield stress of the material should be measured according to Test Method D6693/D6693M in the same direction as the direction tested for stress cracking, converting to stress the values measured in force per unit width by the thickness measured per Test Method D5199. When the test is conducted on a plaque molded per Procedure C of Practice D4703, yield stress shall be measured on the same plaque as the one on which the test specimens are sampled. Five specimens should be tested and the average