



Designation: ~~D3111~~ – ~~10~~ **D3111 – 10 (Reapproved 2018)**

## Standard Test Method for Flexibility Determination of Hot-Melt Adhesives by Mandrel Bend Test Method<sup>1</sup>

This standard is issued under the fixed designation D3111; the number immediately following the designation indicates the year of original adoption or, in the case of revision, the year of last revision. A number in parentheses indicates the year of last reapproval. A superscript epsilon ( $\epsilon$ ) indicates an editorial change since the last revision or reapproval.

### 1. Scope

1.1 This test method covers the determination of the flexibility of a hot-melt adhesive in sheet form under specific test conditions. This is a working test. Its results are useful for comparing adhesives, not for absolute characterization of adhesives.

1.2 The values stated in SI units are to be regarded as the standard. The values given in parentheses are for information only.

1.3 *This standard does not purport to address all of the safety concerns, if any, associated with its use. It is the responsibility of the user of this standard to establish appropriate safety, health, and environmental practices and determine the applicability of regulatory limitations prior to use.*

1.4 *This international standard was developed in accordance with internationally recognized principles on standardization established in the Decision on Principles for the Development of International Standards, Guides and Recommendations issued by the World Trade Organization Technical Barriers to Trade (TBT) Committee.*

### 2. Referenced Documents

2.1 *ASTM Standards:*<sup>2</sup>

[D907 Terminology of Adhesives](#)

[E171/E171M Practice for Conditioning and Testing Flexible Barrier Packaging](#)

### 3. Terminology

3.1 *Definitions*—Many of the terms found in this test method are defined in Terminology [D907](#).

3.2 *Definitions of Terms Specific to This Standard:*

3.2.1 *flexibility, n*—that property of a material by virtue of which it may be flexed or bowed repeatedly without undergoing rupture.

### 4. Summary of Test Method

4.1 Test strips of a hot-melt adhesive properly sized and conditioned, are bent 180° over a mandrel (rod). Using a fresh specimen for each test, the test is repeated with smaller diameter mandrels until the adhesive fails on bending. The flexibility of the adhesive is the smallest diameter mandrel over which four out of five test specimens do not break.

### 5. Significance and Use

5.1 The “Mandrel Bend” test is simple and fast. It requires little investment in equipment and little operator training. The prime purpose is to determine whether a hot-melt adhesive meets flexibility requirements. This test is also useful for comparing flexibility of several adhesives. It can be used to design adhesives by comparing the flexibility of various formulations to meet specific end use parameters. The adhesive flexibility can be determined at temperatures other than ambient by conditioning the test apparatus and test specimens at the desired temperature and performing the test under these temperature conditions.

### 6. Apparatus

6.1 The test apparatus consists of a series of different diameter cylindrical rods or mandrels supported at each end. There shall be enough space to permit placement of the flat side of a test specimen tangentially at right angles to the longitudinal axis of the

<sup>1</sup> This test method is under the jurisdiction of ASTM Committee [D10](#) on Packaging and is the direct responsibility of Subcommittee [D10.14](#) on Tape and Labels. Current edition approved Oct. 1, 2010/Dec. 15, 2018. Published October 2010/January 2019. Originally approved in 1972. Last previous edition approved in 2004/2010 as [D3111 – 99 \(2004\)D3111 – 10](#).<sup>1</sup> DOI: [10.1520/D3111-10](#); [10.1520/D3111-10R18](#).

<sup>2</sup> For referenced ASTM standards, visit the ASTM website, [www.astm.org](#), or contact ASTM Customer Service at [service@astm.org](#). For *Annual Book of ASTM Standards* volume information, refer to the standard’s Document Summary page on the ASTM website.

test mandrel. Individual requirements determine the diameter and lengths of the rods needed. For most tests, 3.2 mm (~1/8 in.), 6.4 mm (~1/4 in.), and 12.8 mm (~1/2 in.) diameter by 75 to 150-mm (~3 to 6-in.) long rods made of brass or stainless steel are satisfactory. Fig. 1 describes two simple test frames, one with fixed mandrels and the other designed to take any diameter mandrel.

7. Test Specimen

7.1 The test specimen dimensions can be varied depending on the end use requirements of the hot-melt adhesive. Fig. 2 describes a recommended specimen size. It is 10 mm (~0.4 in.) wide, 75 mm (~3 in.) long and 1.25 ± 0.01 mm (~0.05 in.) thick. The thickness dimension is critical and must be accurately measured. The test specimens shall be cut from molded or extruded sheets or film. Plying of several thinner samples shall not be permitted. No flaws visible anywhere in the sample to the naked eye shall be permitted.

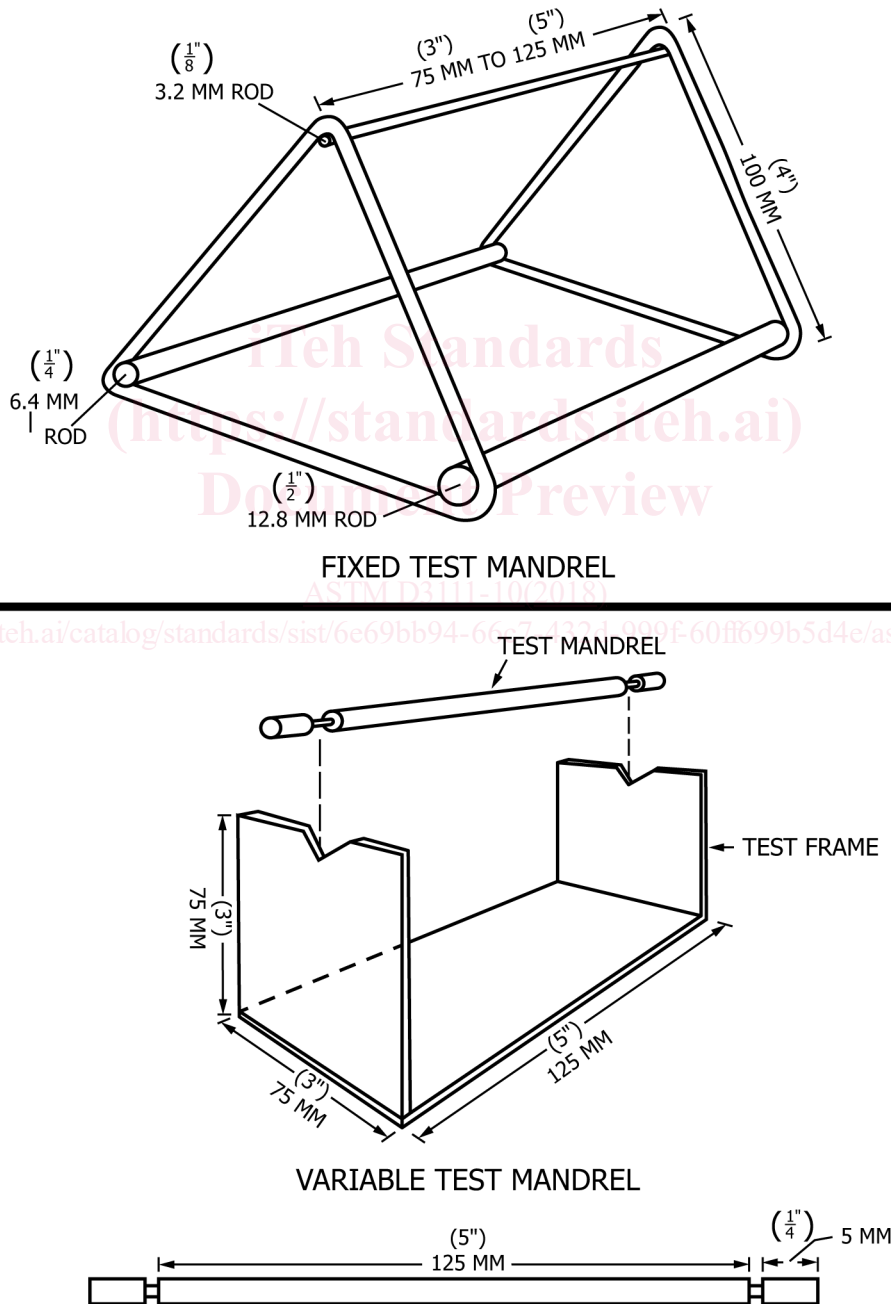

NOTE 1—(Recess to fit test frame) Figures in parentheses are approximate.

FIG. 1 Test Mandrel (Various Diameters) for Test Frame