



Designation: **C1717—12 C1717 – 18**

Standard Test Methods for Conducting Strength Tests of Masonry Wall Panels¹

This standard is issued under the fixed designation C1717; the number immediately following the designation indicates the year of original adoption or, in the case of revision, the year of last revision. A number in parentheses indicates the year of last reapproval. A superscript epsilon (ϵ) indicates an editorial change since the last revision or reapproval.

INTRODUCTION

Engineered design of masonry structures requires accurate technical data on the strength and load-deflection behavior of masonry wall elements. These test methods provide a systematic basis for obtaining such data.

1. Scope*

1.1 These test methods cover methods for determining the strength and load-deflection characteristics of masonry wall elements.

1.2 The values stated in inch-pound units are to be regarded as standard. The values given in parentheses are mathematical conversions to SI units that are provided for information only and are not considered standard.

1.3 *This standard does not purport to address all of the safety concerns, if any, associated with its use. It is the responsibility of the user of this standard to establish appropriate safety, health, and environmental practices and determine the applicability of regulatory limitations prior to use.*

1.4 *This international standard was developed in accordance with internationally recognized principles on standardization established in the Decision on Principles for the Development of International Standards, Guides and Recommendations issued by the World Trade Organization Technical Barriers to Trade (TBT) Committee.*

2. Referenced Documents

2.1 *ASTM Standards:*²

C1232 Terminology for Masonry

E2126 Test Methods for Cyclic (Reversed) Load Test for Shear Resistance of Vertical Elements of the Lateral Force Resisting Systems for Buildings

3. Terminology

3.1 *Definitions*—Terminology defined in Terminology **C1232** shall apply for this specification.

4. Significance and Use

4.1 The test methods described in this standard are intended for use as a starting point in developing specific testing protocols for masonry elements.

4.1.1 The testing protocols could be used for general research on the load-deflection behavior of masonry elements.

4.1.2 The testing protocols could be used for qualification of masonry elements and materials by evaluation services and other parties.

4.1.3 The test methods described in this standard are general, and are intended to be adaptable to address a wide range of anticipated support and loading conditions.

4.2 How the test results are interpreted will depend on the intended use of the masonry element being tested.

¹ These test methods are under the jurisdiction of ASTM Committee **C15** on Manufactured Masonry Units and is the direct responsibility of Subcommittee **C15.04** on Research.

Current edition approved Dec. 1, 2012/Dec. 15, 2018. Published December 2012/January 2019. Originally approved in 2009. Last previous edition approved in 2010/2012 as **C1717—04/C1717 – 12**. DOI: 10.1520/C1717-12.10.1520/C1717-18.

² For referenced ASTM standards, visit the ASTM website, www.astm.org, or contact ASTM Customer Service at service@astm.org. For *Annual Book of ASTM Standards* volume information, refer to the standard's Document Summary page on the ASTM website.

*A Summary of Changes section appears at the end of this standard

5. Test Specimens

5.1 *General Description*—The specimens shall have materials and workmanship representative of the structural elements they are intended to represent, and be large enough to be useful in predicting the structural performance of those elements.

5.2 *Length or Height*—The specimen shall be long enough (for horizontal testing) or tall enough (for vertical testing) so that its behavior under load will simulate that of the element that the specimen is intended to represent.

5.3 *Width*—The specimen shall be wide enough so that its behavior under load will simulate that of the element the specimen is intended to represent.

5.4 *Laboratory Environment*—Maintain the air in the laboratory at a temperature of $75 \pm 15^{\circ}\text{F}$ ($24 \pm 8^{\circ}\text{C}$) and a relative humidity of $55 \pm 25\%$.

5.5 *Preconditioning of Masonry Materials*—Precondition materials by storing in the laboratory environment for at least 5 days before use.

5.6 *Age*—Test masonry construction at an age of at least 28 days after fabrication, unless specified otherwise.

6. General Requirements for Instrumentation

6.1 *Load Measurement*—Measure loads with a load cell or pressure transducer having a precision better than or equal to 1 % of the expected maximum load.

6.2 *Displacement Measurement*—Measure displacements with a linear potentiometer, linear variable displacement transformer (LVDT), or dial gauge having a precision equal to or better than the lesser of $\pm 1\%$ of the expected maximum displacement, or ± 0.02 in. (± 0.5 mm).

6.3 *Data Acquisition*—Record sufficient data to define the load-displacement curve with sufficient precision for the purposes of the test. Each set of data (load and displacement) is referred to as a “loading point.”

7. General Requirements for Loading

7.1 *Loading Method*—Load specimens hydraulically using a hand pump, electrical pump, or air-driven pump.

7.2 *Test Control*—Control the load manually or automatically (servo-controlled feedback system).

7.2.1 *Manual Control*—If the load is controlled manually, displacements are imposed on the specimen. The loading protocol may be based on target loads or target displacements. It is generally convenient to use target loads until the load level approaches the expected capacity, and then use target displacements.

7.2.2 *Automatic Control*—If the load is controlled automatically, either load or displacement is imposed on the system. The loading protocol may be based on target loads or target displacements. Use load control until the load level approaches the expected capacity, and then use displacement control.

7.3 *Loading Protocol*—Use a loading protocol that is appropriate for the purposes of the test. The simplest loading protocol is monotonic loading to failure. A more complex loading protocol is cycles of loading (possibly reversed) to monotonically increasing maximum amplitudes. Other protocols shall be permitted to be used.

NOTE 1—A wide range of loading protocols for in-plane tests is provided in Test Methods E2126.

8. Axial Compression Test

8.1 *Apparatus*—Use a test setup incorporating the essential aspects of Fig. 1. Design the test setup to resist at least twice the maximum anticipated load. Design the test setup so its stiffness parallel to the axis of the specimen is at least 10× the anticipated axial stiffness of the specimen itself. The bottom of the specimen shall be simply supported (with a zero or non-zero eccentricity) or restrained. The top of the specimen shall be simply supported (with a zero or non-zero eccentricity) or restrained. Apply the axial load at the top with a zero or non-zero eccentricity. Apply the load uniformly along the top of the specimen.

8.2 *Instrumentation:*

8.2.1 *Axial Load*—Measure the applied axial load.

8.2.2 *Axial Deformation*—Attach a bracket to the specimen near the upper end, supporting a metal rod. Attach another bracket to the specimen near its lower end, supporting a displacement gauge. Other means of measuring the axial deformation shall be acceptable, provided that they meet the requirements of 6.2.

8.2.3 *Out-of-plane Deflection*—Measure out-of-plane deflection using either a reference line attached to the wall, or a fixed reference.

8.2.3.1 *Out-of-plane Deflection Using a Reference Line*—Measure out-of-plane deflection using a deflection gauge oriented perpendicular to the plane of the wall, and placed at the mid-height and plan mid-length of the wall. Alternatively, use two deflection gauges oriented perpendicular to the plane of the wall, and placed at the mid-height and plan ends of the wall. Attach one end of the deflection gauge or gauges to the wall, and the other end to a reference line between the top and bottom of the wall.

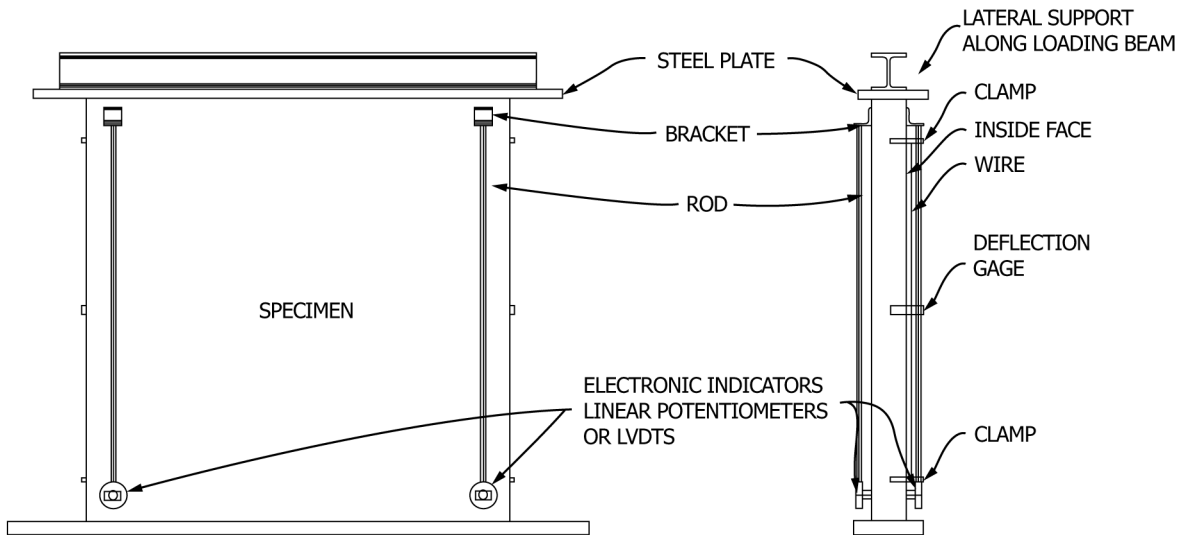

FIG. 1 Test Setup for Axial Compressive Loading

8.2.3.2 *Out-of-plane Deflection Using a Fixed Reference*—Use three deflection gauges, oriented perpendicular to the plane of the wall, one placed at mid-height, the other two placed at the top and the bottom, and all placed at the plan mid-length of the wall. Attach one end of each deflection gauge to the wall, and attach the other end to a fixed reference.

8.3 *Data Recording*—Report the bottom support conditions and eccentricity. At each loading point, record the applied load, axial deformation of each axial deformation gauge and the average of these deformations, and the out-of-plane deflection.

9. Transverse Quarter-Point Loading—Specimen Horizontal

9.1 *Apparatus*—The apparatus shall incorporate the essential aspects of Fig. 2, and be able to withstand at least twice the anticipated maximum load, with a maximum deformation not more than 1 % of the expected deformation of the specimen.

9.1.1 *Roller Supports*—Provide steel roller supports with steel bearing plates between the roller supports and the specimen. Use compressible shims or a bed of gypsum capping material to ensure uniform application of the support reaction.

9.1.2 *Loading Assembly*—The loading assembly shall consist of two steel rollers with a steel plate between each loading roller and the specimen. Use full-length, compressible shims or a bed of gypsum capping material to ensure uniform application of load.

9.1.3 *Hydraulic Ram.*

9.1.4 *Load-measurement Devices.*

9.1.5 *Deflection Gauges*—Place a reference frame on the upper face of the specimen. To prevent stresses from deforming the frame as the specimen deforms under load, support this frame on three hardened steel balls, each supported by a steel block on the face of the specimen. Place two of the balls in a line vertically above one support, and the third ball vertically above the other support. Attach two deflection gauges to the frame at midspan, one near each longitudinal edge of the specimen. Other means of measuring the difference between the support and midspan deflections shall be acceptable, provided that they meet the requirements of 6.2.

9.2 *Procedure:*

9.2.1 *Loading*—Apply the load to the designated face of the specimen.

9.2.1.1 *Quarter-point Loading*—Test the specimen as a simply supported beam (Fig. 2) on a span approximately 6 in. (150 mm) less than the specimen length. Apply two equal loads, each at a distance of one quarter of the span from the supports, toward the middle of the span. Measure the loads using a single load cell between the hydraulic ram and the loading beam, or using two load cells, one at each end of the loading beam. The reported load on the specimen shall include the weight of specimen between the supports.

9.2.1.2 *Uniformly Distributed Loading*—Uniformly distributed loading shall be permitted to be used instead of quarter-point loading, if a satisfactory method is available. Transverse load, uniformly distributed, may be applied by air pressure, either in a bag or in a chamber having the specimen as one face. Support specimens tested under uniform loading by rollers as for quarter-point loading.

9.2.2 *Strength on Short Span*—If the strength of the construction for a shorter span is desired, do not compute it, but test the construction on the short span.

9.3 *Data Recording*—At each loading point, record the applied load and the reading of each deflection gauge. Compute the deflection of the midspan of the specimen as the average of the two deflection gauges.

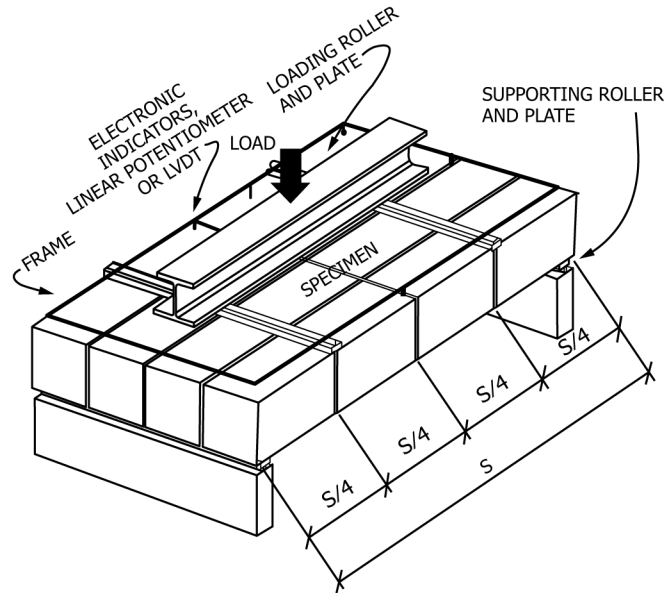

FIG. 2 Test Setup for Transverse Quarter-point Loading (Specimen Horizontal)

10. Transverse Quarter-Point Loading—Specimen Vertical

10.1 *Apparatus*—The apparatus shall incorporate the essential features of Fig. 3, and be able to withstand at least twice the anticipated maximum load, with a maximum deformation not more than 1% of the expected deformation of the specimen.

10.1.1 *Steel Channel.*

10.1.2 *Roller Supports*—Provide steel roller supports with steel bearing plates between the roller supports and the specimen. Use full-length, compressible shims or a bed of gypsum capping material to ensure uniform application of the support reaction. Use roller and plates of sufficient stiffness to ensure uniform loading across the specimen width.

10.1.3 *Loading Assembly*—The loading assembly shall consist of two steel rollers with a steel plate between each loading roller and the specimen. Use full-length, compressible shims or a bed of gypsum capping material to ensure uniform application of load. Use roller and plates of sufficient stiffness to ensure uniform loading across the specimen width.

10.1.4 *Hydraulic Ram.*

10.1.5 *Load-measurement Devices.*

10.1.6 *Out-of-plane Deflection Gauges*—Two sets of deflection gauges. Other means of measuring the difference between the support and midspan deflections shall be acceptable, provided that they meet the requirements of 6.2.

10.2 *Procedure*—The specimen, on a steel channel, shall be supported laterally by cylindrical rollers to prevent end restraint. The axes of the rollers shall be parallel to the faces of the specimen. The two supporting rollers shall be in contact with the vertical surface of the frame and each roller shall rest horizontally on neoprene pads about 0.4-in. (10-mm) thick to prevent longitudinal restraint. Each of the two loading rollers shall also rest on neoprene pads. Apply the loads horizontally by a hydraulic ram and measure using a load cell between the hydraulic ram and the specimen, or using two load cells, one between the specimen and each end of the loading beam. Attach two sets of out-of-plane deflection gauges to the specimen, one set at the mid-height of each vertical edge.

10.2.1 Apply the transverse load to the designated face of the specimen.

10.2.1.1 *Quarter-point Loading*—Test the specimen as a simply supported beam (Fig. 3)-(a)) on a span approximately 6 in. (150 mm) less than the specimen length. Apply two equal loads, each at a distance of one quarter of the span from the supports, toward the middle of the span.

10.2.1.2 *Uniformly Distributed Loading*—Uniformly distributed loading shall be permitted to be used instead of quarter-point loading, if a satisfactory method is available. Transverse load, uniformly distributed, may be applied by air pressure, either in a bag or in a chamber having the specimen as one face-face (Fig. 3 (b)). Support specimens tested under uniform loading by rollers as for quarter-point loading.

10.2.2 Connect a reaction platform parallel to the face to be loaded and wider than the specimen to the supports by tie rods. Place an airtight bag as wide as the specimen and as long as the span between the specimen and the reaction platform. Apply transverse load to the specimen by increasing the air pressure in the bag. Measure the pressure by means of a manometer or other pressure-measuring device. The error of the pressure reading shall not exceed 1 %.

10.3 *Data Recording*—At each loading point, record the applied load and the reading of each deflection gauge. Compute the deflection of the midspan of the specimen as the average of the two deflection gauges.