



Designation: D6478 – 10 (Reapproved 2019)

Standard Test Method for Determining Specific Packability of Fabrics Used in Inflatable Restraints¹

This standard is issued under the fixed designation D6478; the number immediately following the designation indicates the year of original adoption or, in the case of revision, the year of last revision. A number in parentheses indicates the year of last reapproval. A superscript epsilon (ϵ) indicates an editorial change since the last revision or reapproval.

1. Scope

1.1 This test method covers procedures for determining the ability to fold and pack fabrics used for inflatable restraints using an index of specific packability.

1.2 Procedures in this test method describe operator techniques that must be followed closely to obtain repeatable and accurate results. Since these techniques are difficult to convey in writing, supplemental training for operators is required. A training video is available from ASTM (see Adjuncts [ADJD6478](#) and [ADJD6478A](#)).

1.3 The values stated in SI units are to be regarded as standard. No other units of measurement are included in this standard.

1.4 Procedures and apparatus other than those stated in this practice may be used as agreed upon between the purchaser and the supplier with specific deviations from this practice acknowledged in the report.

1.5 *This standard does not purport to address all of the safety concerns, if any, associated with its use. It is the responsibility of the user of this standard to establish appropriate safety, health, and environmental practices and determine the applicability of regulatory limitations prior to use.*

1.6 *This international standard was developed in accordance with internationally recognized principles on standardization established in the Decision on Principles for the Development of International Standards, Guides and Recommendations issued by the World Trade Organization Technical Barriers to Trade (TBT) Committee.*

2. Referenced Documents

2.1 *ASTM Standards:*²

[D123 Terminology Relating to Textiles](#)

¹ This test method is under the jurisdiction of ASTM Committee [D13](#) on Textiles and is the direct responsibility of Subcommittee [D13.20](#) on Inflatable Restraints.

Current edition approved Jan. 1, 2019. Published January 2019. Originally approved in 1999. Last previous edition approved in 2014 as D6478–10 (2014). DOI: 10.1520/D6478-10R19.

² For referenced ASTM standards, visit the ASTM website, www.astm.org, or contact ASTM Customer Service at service@astm.org. For *Annual Book of ASTM Standards* volume information, refer to the standard's Document Summary page on the ASTM website.

[D1776 Practice for Conditioning and Testing Textiles](#)

[D2904 Practice for Interlaboratory Testing of a Textile Test Method that Produces Normally Distributed Data \(Withdrawn 2008\)](#)³

[D6799 Terminology Relating to Inflatable Restraints](#)

[E691 Practice for Conducting an Interlaboratory Study to Determine the Precision of a Test Method](#)

2.2 *ASTM Adjuncts:*

[ADJD6478](#) — 17 Detailed Drawings⁴

[ADJD6478A](#) — Videotape-Supplemental Training⁴

3. Terminology

3.1 For all terminology relating to D13.20, Inflatable restraints, refer to Terminology [D6799](#).

3.1.1 The following terms are relevant to this standard: inflatable restraint, packability, specific packability.

3.2 For all other terms related to textiles, see Terminology [D123](#).

4. Summary of Test Method

4.1 A fabric specimen is folded uniformly in a “Z” pattern in the warp and fill directions.

4.2 The folded specimen is placed into a transparent box that confines the specimen securely during compression.

4.3 The folded specimen is compressed using a tensile tester outfitted with special hardware, and the resulting volume is recorded at specified loads. The total of all the individual volumes recorded at each specified cell is the specific packability of the fabric.

5. Significance and Use

5.1 This test method is useful for determining the specific packability of uncoated and coated airbag fabrics. Fabric packability is an important factor in the design of airbag modules due to their inherent spacial constraints.

³ The last approved version of this historical standard is referenced on www.astm.org.

⁴ Available from ASTM International Headquarters. For 17 Detailed CAD Drawings, Order Adjunct No. [ADJD6478](#). For Videotape-Supplemental Training, Order [ADJD6478A](#).

5.2 A folded specimen exhibits better specific packability if it occupies a lower total volume at the specified loads compared to another specimen.

5.3 The time required to test one sample (four specimens from the same lot of fabric) is approximately 1.5 h using this test method. Due to the length of time required by this test method to perform a single test, this test method is most suitable for use in design and development analysis or for inclusion in a list of required tests conducted for annual certification of an airbag fabric.

6. Apparatus

6.1 *Tensile Tester*, outfitted with a rigid base to support the specimen box, and a compression foot attached to the load cell with a coupling having adjustment and locking capability to maintain fixed parallel alignment to the base. Tensile tester should be calibrated annually by an independent agency whose results are traceable to the National Institute of Science and Technology (NIST) or other national standards laboratory.

NOTE 1—The frame of the tensile tester can be used as the rigid base if it is a solid metal surface which can support compression loading of 200N without deforming, is perfectly flat, and supports the entire footprint of the specimen box.

6.2 *Apparatus Manufactured in Accordance With Drawings*⁵ (See Fig. 1):

6.2.1 *Rectangular Box*, 100 by 150 ± 0.1mm with 99 by 149 ± 0.1 mm cover plate constructed of transparent polycarbonate material.

6.2.2 *Rectangular Template and Rotary Cutting Pad*, 750 by 800 mm ± 0.5 mm, for cutting specimens from fabric samples (optional).

6.2.3 *Jig*, consisting of two sets of slats (wide and narrow) for making the folds and a frame that holds the slats in position during folding.

6.2.4 *Compression Gage Blocks*, with thickness of 10, 20, and 30 ± 0.1 mm.

6.2.5 All dimensions shall be verified at time of manufacture using measuring devices traceable to the National Institute of Science and Technology (NIST) or other national standards laboratory.

6.3 *Rotary Razor Cutter*.

6.4 *Large Paperclips (Three)*, preferably with a serrated surface to improve gripping capability.

6.5 *Permanent Marking Pen*, pen with fine tip.

7. Specimen Preparation

7.1 Condition fabric samples for a minimum of 3 h in the standard atmosphere for testing textiles in accordance with Practice D1776.

7.2 Without fraying or fusing the edges, cut four 750 by 800 ± 5-mm specimens from each sample, with the 800-mm

⁵ Equipment designed by AlliedSignal Performance Fibers, is manufactured according to drawing #61-27A-7906-2 and is available from Precision Machine Company, Inc., 2915 West Lehigh Street, Richmond, VA 23230. Copyright for CAD drawings held by AlliedSignal and provided to ASTM with full unlimited authorization to distribute copies and/or to designate other parties to distribute copies.

dimension aligned in the warp direction and the cuts aligned with the warp and weft yarns in the fabric.

7.3 Write the fabric sample identification and the specimen number on the lower right corner of the specimen (warp yarns running up/down and weft yarns running right/left relative to the operator) at a location about 50 mm from the bottom edge and 50 mm from the right edge.

8. Procedure

8.1 *Tensile Tester Set-Up and Calibration Check*: (See X1.1.)

8.1.1 Set tensile tester for compression mode, install load cell with maximum force rating of 200 to 1000N, set crosshead speed to 25.0 ± 1.0 mm/min, set data acquisition equipment to record thickness with an accuracy of 0.1 mm at loads of 20 to 180N in 20N increments (nine total points), set sampling frequency at ≥ 25 Hz and set test endpoint at 200N

8.1.2 Mount the rigid base to the tensile tester frame, mount the coupling to the load cell, and attach the compression foot to the coupling, leaving the adjustment locking mechanism loose. (See Note 1)

8.1.3 Lower the crosshead slowly until 200 ± 50N force is achieved and lock the compression foot into position. (See X1.1.1.)

8.1.4 Raise the crosshead until there is a gap of approximately 1 mm between the compression foot and the base and visually check for parallel alignment in both directions. (See X1.1.2.)

8.1.5 Raise the crosshead, place the specimen box on the tensile tester base, and insert the top cover plate into the box.

8.1.6 Raise the specimen box by hand until the compression foot is inside the box, then lower the crosshead and box together until the box rests on the support base and the compression foot is not touching the cover plate. Position the box so that the compression foot is in the approximate center of the box.

NOTE 2—Exercise caution to avoid possible operator injury from the pinch-point between the compression foot and the specimen box.

8.1.7 Lower the crosshead until a force of 100 ± 30N is achieved and set zero.

NOTE 3—An alternate zero can be used to simplify the test. To use the alternate zero, set the true zero as specified, raise the crosshead to the desired point, and zero the crosshead position again. The position of the alternate zero should be selected such that the compression foot does not touch the cover plate when the fabric specimen is in the box. A position of +35 mm is suitable for most airbag fabrics.

8.1.8 Raise the crosshead, place the specimen box on the tensile tester base, insert the 10-mm gage block and then the cover plate into the box.

8.1.9 Raise the specimen box by hand until the compression foot is inside the box, then lower the crosshead and box together until the box rests on the support base and the compression foot is not touching the cover plate. Position the box so that the compression foot is in the approximate center of the box. (See X1.1.3.)

8.1.10 Initiate the compression test and record thickness at all specified loads.

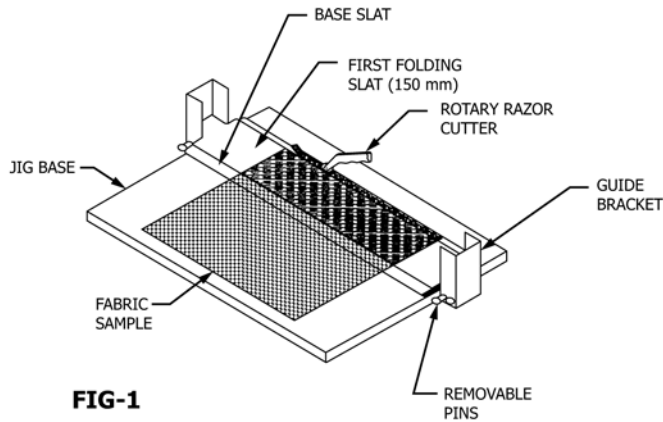

FIG-1

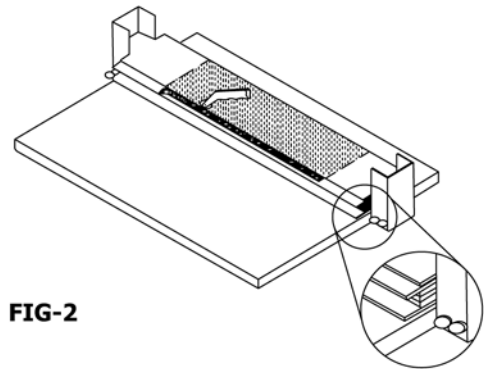

FIG-2

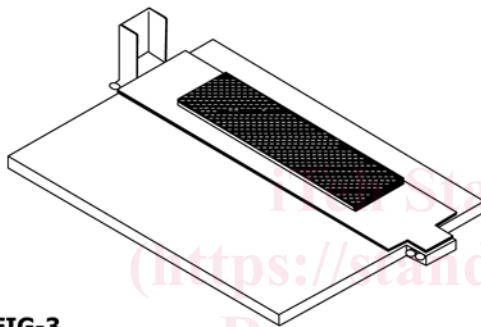

FIG-3

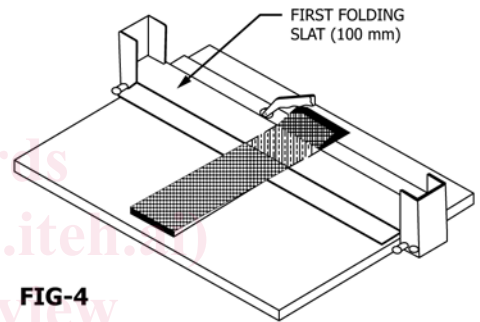

FIG-4

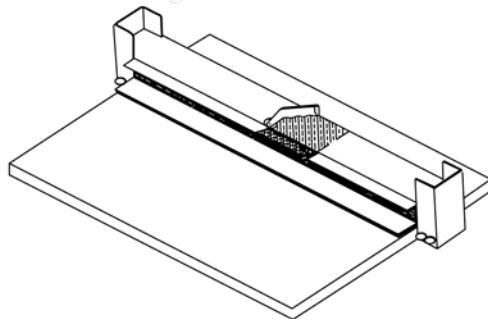

FIG-5

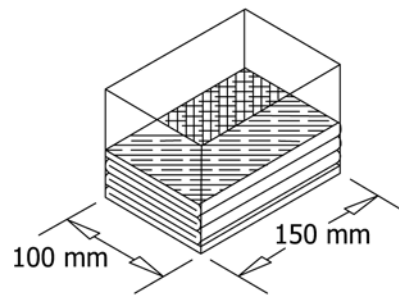

FIG-6

FIG. 1 Apparatus

8.1.11 Repeat 8.1.8 – 8.1.10 using the 20 and 30-mm gage blocks.

8.1.12 Ensure that the thickness measured for each gage block at 100N force is within $\pm 5.0\%$ of the actual thickness. Excessive variation indicates the need for equipment servicing.

8.2 Specimen Folding: (See X1.2.)

8.2.1 Place the folding jig on a table approximately 0.8 m in height with the “A” side of the jig to the left of the operator and place all slats on the table in ascending numerical order from

top to bottom. The “A” and “B” identification marks on the jig base and all slats indicate correct orientation for installation and numbers on the slats indicate the correct sequence for installation. (See X1.2.1.)

8.2.2 Place the base slat in the jig.

8.2.3 Place the fabric specimen in the jig with the identification mark up and at the bottom right corner, nearest the operator, and align the edges of the specimen with the outer guide lines on the jig base.

8.2.4 Fold the specimen using the wide slats, #1 to #5, visually inspecting and adjusting at each step to ensure that all folds are straight, are aligned to within ± 1 mm and that the fabric is tight around the slats.

NOTE 4—If slippage or misalignment occurs, the following procedure can be repeated using the same specimen if there is sufficient fabric remaining for the trimming step at the beginning and end of the folding process.

8.2.4.1 Install slat #1 on top of the fabric specimen. Slide the specimen into position so that the fabric protrudes approximately 5 mm under the back edge of the slat.

8.2.4.2 Run the rotary razor cutter along the back edge of slat #1 and remove the trimmed excess fabric. (See X1.2.2.)

8.2.4.3 Pull the fabric front to back across the top of slat #1, and install slat #2.

8.2.4.4 Pull the fabric from back to front across the top of slat #2, and install slat #3. (See X1.2.3.)

8.2.4.5 Pull the fabric from front to back across the top of slat #3, and install slat #4.

8.2.4.6 Pull the fabric from back to front across the top of slat #4, and install slat #5.

8.2.4.7 Run the rotary razor cutter along the front edge of slat #5 and remove the trimmed excess fabric. (See X1.2.4.)

8.2.5 Position the jig so that the “B” side faces toward the operator.

8.2.6 Using a fine-tip permanent marker, make thin horizontal marks on the fabric at three locations along the right side of slots #2 and #4 as indicated by guide lines on the jig base. Make thin vertical marks on the fabric specimen adjacent to the horizontal marks using a vertical edge of the 30 mm gage block as a guide. When making the vertical marks, insert the pen tip slightly under slat #1 so that the bottom single layer of fabric also will be marked. (See X1.2.5.)

8.2.7 Remove the slat bracket on the “B” side.

8.2.8 Remove the wide slats one at a time from top to bottom.

8.2.8.1 Slide slat #5 out and slightly left.

8.2.8.2 Slide slat #4 out and slightly left.

8.2.8.3 Slide slat #3 out and slightly right. (See X1.2.6.)

8.2.8.4 Slide slat #2 out and slightly left.

8.2.8.5 Slide slat #1 out and slightly right.

8.2.9 Pinch the fabric folds and the single layer of fabric together using the horizontal and vertical marks to align the edges directly on top of each other. Insert a large paperclip halfway over the tow folds and the edge of the single layer of fabric at each of the three locations marked.

8.2.10 Invert the folded stack and adjust the individual folds and the edge of the single fabric layer so that the alignment is exact at each of the three locations clipped. Carefully revert the folded stack so that the specimen identification mark is on the top.

8.2.11 Reinstall the slat bracket on the “B” side.

8.2.12 Position the jig with the “A” side left of the operator, position the folded stack so the specimen identification mark is at the front edge of the jig facing the operator, and align the edges of the folded stack with the inner guidelines on the jig base. (See X1.2.7.)

8.2.13 Fold the specimen using the narrow slats #1 to #7, visually inspecting and adjusting at each step to insure that all folds are straight, are aligned to within ± 1 mm and that the fabric is tight around the slats. (See X1.2.8.)

NOTE 5—If slippage or misalignment occurs, the procedure below can be repeated using the same specimen if there is sufficient fabric remaining for the trimming step at the beginning and end of the folding process.

8.2.13.1 Install slat #1 on top of the fabric specimen. Slide the specimen into position so that the fabric protrudes approximately 5 mm under the back edge of the slat.

8.2.13.2 Check and adjust the relative alignment of the folded edges under slat #1 so that they are directly on top of each other.

8.2.13.3 Use the back edge of slat #1 to hold the folded specimen in position and remove the paperclip under the slat.

8.2.13.4 Run the rotary razor cutter along the back edge of slat #1 and remove the trimmed excess fabric. (See X1.2.9.)

8.2.13.5 Pull the fabric from front to back across the top of slat #1, and install slat #2.

8.2.13.6 Pull the fabric from back to front across the top of slat #2, and install slat #3.

8.2.13.7 Pull the fabric from front to back across the top of slat #3, and install slat #4.

8.2.13.8 Remove the second paperclip from under slat #4.

8.2.13.9 Pull the fabric from back to front across the top of slat #4, and install slat #5.

8.2.13.10 Pull the fabric from front to back across the top of slat #5, and install slat #6.

8.2.13.11 Pull the fabric from back to front across the top of slat #6, and install slat #7.

8.2.13.12 Remove the third paperclip from under slat #7.

8.2.13.13 Run the rotary razor cutter along the front edge of slat #7 and remove the trimmed excess fabric.

8.2.14 Position the jig so that the “B” side faces toward the operator.

8.2.15 Remove the slat bracket for the “B” side.

8.2.16 Remove the narrow slats one at a time from top to bottom.

8.2.16.1 Slide slat #7 out and slightly left, and slide the specimen box cover plate on top of the folded specimen as the slat is moved away to prevent the specimen from unfolding. The cover plate should be oriented with “front” to the right side and facing upward.

8.2.16.2 Slide slat #6 out and slightly left.

8.2.16.3 Slide slat #5 out and slightly right.

8.2.16.4 Slide slat #4 out and slightly left.

8.2.16.5 Slide slat #3 out and slightly right.

8.2.16.6 Slide slat #2 out and slightly left.

8.2.16.7 Slide slat #1 out and slightly right.

8.2.17 Pick up the specimen with the cover plate on top, and invert both together so that the cover plate is on the bottom. (See X1.2.10.)

8.2.18 Hold the empty specimen box in the other hand with the open end downward and the “front” to the left side.

8.2.19 Insert the specimen up into the box without disturbing the folds or compressing the specimen.

NOTE 6—If the specimen is folded properly, it will slide into the box with little resistance, and also will slide back out of the box under only the

force of gravity. If this condition is not met, the specimen should be discarded.

8.2.20 Revert the box with the specimen and cover plate inside so the open end is upward.

8.2.21 Visually inspect the folded specimen through the clear box. Reject the specimen if edges of the folds made using the wide slats are misaligned by more than ±1 mm at any point.

8.3 *Compression Testing:* (See X1.3.)

8.3.1 Raise the crosshead and place the specimen box on the rigid base in the designated orientation.

8.3.2 Raise the specimen box by hand until the compression foot is inside the box but is not touching the cover plate, so that the sample is not compressed.

8.3.3 Lower the crosshead and specimen box together until the box rests on the support base. Do not allow the compression foot to touch the cover plate and compress the specimen during this step.

NOTE 7—Using an alternate zero (Note 2) will simplify this step if the tensile tester can be set to return automatically to the zero point.

8.3.4 Position the specimen box such that the compression foot is visually centered inside the box in both directions.

8.3.5 Start the compression tester and record specimen thickness at each specified force. (See X1.3.1.)

8.4 *Calculation and Error Correction:*

8.4.1 Calculate the measurement error for each gage block at each specified force and calculate the average error of all three gage blocks at each specified force. *Example*—The error for the 10 mm gage block at 20N force and the average error at 20N force are:

$$E_{20(10\text{ mm})} = G_{20(10\text{ mm})} - 10 \tag{1}$$

$$E_{20(A)} = (E_{20(10\text{ mm})} + E_{20(20\text{ mm})} + E_{20(30\text{ mm})})/3$$

where:

- $E_{20(10\text{ mm})}$ = error in measured thickness of 10mm gage block at 20N compression force,
- $G_{20(10\text{ mm})}$ = measured thickness of 10mm gage block at 20N compression force, and
- $E_{20(A)}$ = average thickness measurement error at 20N compression force.

8.4.2 Adjust the measured thickness data for error at each specified force using the average error previously calculated. *Example*—The corrected thickness of the specimen at a force of 20N is:

$$T_{20(c)} = T_{20(m)} - E_{20(A)} \tag{2}$$

where,

- $T_{20(c)}$ = corrected specimen thickness at 20N compression force, and
- $T_{20(m)}$ = measured specimen thickness at 20N compression force.

8.4.3 Calculate the specific packability volume of the specimen; add the corrected thickness values at all specified loads, multiply by the dimensions of the specimen box and convert the resultant value from [mm³] to [cm³]. This is defined as

specific packability of the specimen. *Example*— The specific packability of specimen # 1 is:

$$SP_{(1)} = \frac{[T_{20(c)} + T_{40(c)} + T_{60(c)} + \dots + T_{180(c)}] \times 100 \times 150}{1000} \tag{3}$$

8.4.4 Calculate the average specific packability for the four specimens. This is defined as the specific packability of the sample.

9. Report

9.1 Report the following information:

9.1.1 State that the fabric was tested in accordance with this test method,

9.1.1.1 If deviation from this test method occurred, any reference to this test method shall state: “Testing was performed in accordance with ASTM D6478, with the following changes:”

9.1.2 The purchaser and supplier shall determine the exact form of the report. Unless otherwise specified, the report will provide the following information:

9.1.2.1 Date of testing,

9.1.2.2 Name and signature of person certifying the report,

9.1.2.3 Fabric description including but not limited to fiber type, fiber linear density, nominal construction and coating weight,

9.1.2.4 Roll and lot identification,

9.1.2.5 Specific packability test results,

9.1.2.6 Individual results for all four specimens tested,

9.1.2.7 Coefficient of variance (Cv) for four individual results,

9.1.2.8 Average of four test results, and

9.1.2.9 Relevant specification.

10. Precision and Bias

10.1 An interlaboratory test was conducted in accordance with Practice D2904 and Practice E691. An expanded precision and bias study will be conducted within the next 5 years to satisfy the requirements of Practice E691.

10.2 *Raw Data Table*—Material: 700 dTex (630 denier) 41 × 41 scoured and heatset uncoated airbag fabric.

Test #	Specific Packability
1	2824
2	2899
3	2869
4	2849
5	2858
6	2882
7	2940
8	2937
9	2854
10	2854

10.3 The precision statement below was generated by Practice E691. software package

10.3.1 The number of laboratories, materials, and determinations in this study DOES NOT meet the minimum requirements for determining precision prescribed in Practice E691:

	This Study	Practice E691 , Study Minimum
Laboratories:	1	6
Materials:	1	4
Determinations	10	2

10.3.2 Packability Precision, characterized by repeatability, S_r , r , and reproducibility, S_R , R has been determined for the materials to be:

Materials	Average	S_r	S_R	r	R
630d 41 × 41	2876.5	38.25	38.25	107.1	107.1

10.3.3 Within five years, additional data will be obtained and processed which does meet the requirements of Practice E691.

11. Keywords

11.1 airbag; fabric; inflatable restraint; packability; packing; volume

APPENDIX

X1. REFERENCE PHOTOGRAPHS DISPLAYING CRITICAL STEPS OF TEST METHOD D6478

NOTE X1.1—Due to the complexity of both the test equipment setup and fabric folding procedure in this test method, a series of photographs are provided to guide operators through various steps in this test method.

X1.1 Tensile Tester Set-Up and Calibration Check: See 8.1.

X1.1.1 Locking Compression Foot (see Fig. X1.1 and 8.1.3).

X1.1.2 Checking for Parallel Alignment (see Fig. X1.2, Fig. X1.3 and 8.1.4).

X1.1.3 Specimen Box with 30mm Block (see Fig. X1.4 and 8.1.9).

X1.2 Specimen Folding: Wide and Narrow Slats Separated (see 8.2).

X1.2.1 Slats in Ascending Order (see Fig. X1.5, Fig. X1.6 and 8.2.1).

X1.2.2 Trim Excess Fabric Using Rotary Cutter (see Fig. X1.7 and 8.2.4.2).

X1.2.3 Install Slat No. 3 (see Fig. X1.8 and 8.2.4.4).

X1.2.4 Trim Excess Fabric Using Rotary Cutter (see Fig. X1.9 and 8.2.4.7).

X1.2.5 Mark Vertical and Horizontal Guide Lines (see Fig. X1.10 and 8.2.6).

X1.2.6 Slide Slat No. 3 Out and Slightly Right (see Fig. X1.11 and 8.2.8.3).



FIG. X1.2 Checking for Parallel Alignment

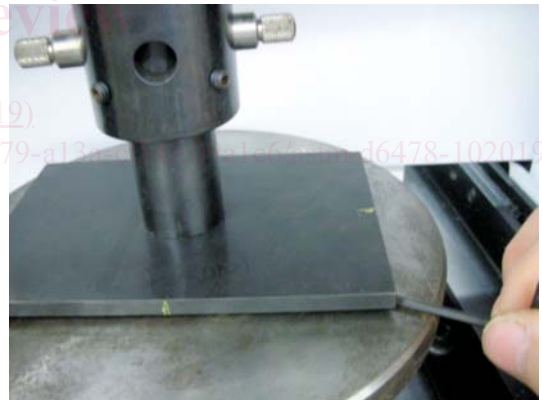

FIG. X1.3 Checking for Parallel Alignment



FIG. X1.1 Locking Compression Foot

X1.2.7 Position Folded Stack and Align Edges (see Fig. X1.12 and 8.2.12).

X1.2.8 Folding Specimen Using Narrow Slats (see Fig. X1.13 and 8.2.13).

X1.2.9 Folded Specimen After Trimming, Prior to Slat Removal (see Fig. X1.14 and 8.2.13.4).

X1.2.10 Example of Folded Specimen (see Fig. X1.15 and 8.2.17).

X1.3 Compression Testing: See 8.3.