



Designation: **E2092—18 E2092 – 18a**

Standard Test Method for Distortion Temperature in Three-Point Bending by Thermomechanical Analysis¹

This standard is issued under the fixed designation E2092; the number immediately following the designation indicates the year of original adoption or, in the case of revision, the year of last revision. A number in parentheses indicates the year of last reapproval. A superscript epsilon (ϵ) indicates an editorial change since the last revision or reapproval.

1. Scope-~~Scope~~*

1.1 This test method describes the determination of the temperature at which the specific modulus of a test specimen is realized by deflection in three-point bending. This temperature is identified as the distortion temperature. The distortion temperature is that temperature at which a test specimen of defined geometry deforms to a level of strain under applied stress of 0.455 MPa (66 psi) (Method A) and 1.82 MPa (264 psi) (Method B) equivalent to those used in Test Method **D648**. The test is applicable over the range of temperature from ambient to 300 °C.

NOTE 1—This test method is intended to provide results similar to those of Test Method **D648** but ~~are~~ performed on a thermomechanical analyzer using a smaller test specimen. Equivalence of results to those obtained by Test Method **D648** has been demonstrated on a limited number of materials. The results of this test method shall be considered to be independent and unrelated to those of Test Method **D648** unless the user demonstrates equivalence.

~~1.2 There is no ISO standard equivalent to this test method.~~

1.2 The values stated in SI units are to be regarded as standard. No other units of measurement are included in this standard.

1.3 *This standard does not purport to address all of the safety concerns, if any, associated with its use. It is the responsibility of the user of this standard to establish appropriate safety, health, and environmental practices and determine the applicability of regulatory limitations prior to use.*

1.4 *This international standard was developed in accordance with internationally recognized principles on standardization established in the Decision on Principles for the Development of International Standards, Guides and Recommendations issued by the World Trade Organization Technical Barriers to Trade (TBT) Committee.*

2. Referenced Documents

2.1 ASTM Standards:²

D648 Test Method for Deflection Temperature of Plastics Under Flexural Load in the Edgewise Position

E473 Terminology Relating to Thermal Analysis and Rheology

E1142 Terminology Relating to Thermophysical Properties

E1363 Test Method for Temperature Calibration of Thermomechanical Analyzers

E2113 Test Method for Length Change Calibration of Thermomechanical Analyzers

E2206 Test Method for Force Calibration of Thermomechanical Analyzers

3. Terminology

3.1 *Definitions*—Specific technical terms used in this standard are defined in Terminologies **E473** and **E1142**, including *stress*, *strain*, and *thermomechanical analyzer*.

3.1.1 *distortion temperature* [$^{\circ}\text{C}$], *n*—the temperature at which an arbitrary strain level is obtained in three-point bending under an arbitrary load.

4. Summary of Test Method

4.1 A test specimen of known dimensions is tested in three-point bending mode. A known stress is applied to the center of a test specimen supported near its ends, as it is heated at a constant rate from ambient temperature to the upper temperature limit

¹ This test method is under the jurisdiction of Committee **E37** on Thermal Measurements and is the direct responsibility of Subcommittee **E37.10** on Fundamental, Statistical and Mechanical Properties.

Current edition approved ~~June 1, 2018~~ Dec. 1, 2018. Published ~~June 2018~~ January 2019. Originally approved in 2000. Last previous edition approved in ~~2013~~ 2018 as ~~E2092—13~~ E2092 – 18. DOI: ~~10.1520/E2092-18~~ 10.1520/E2092-18A.

² For referenced ASTM standards, visit the ASTM website, www.astm.org, or contact ASTM Customer Service at service@astm.org. For *Annual Book of ASTM Standards* volume information, refer to the standard's Document Summary page on the ASTM website.

*A Summary of Changes section appears at the end of this standard

for the material. The deflection of the test specimen is recorded as a function of temperature. The temperature at which a predetermined level of strain is observed in the test specimen is analyzed as the distortion temperature.

5. Significance and Use

5.1 Data obtained by this test method shall not be used to predict the behavior of materials at elevated temperatures except in applications in which the conditions of time, temperature, method of loading, and stress are similar to those specified in the test.

5.2 This standard is particularly suited for quality control and development work. The data are not intended for use in design or predicting endurance at elevated temperatures.

6. Apparatus

6.1 A thermomechanical analyzer consisting of:

6.1.1 *Rigid Specimen Holder*, of inert, low expansivity-coefficient of expansion material $<20 \mu\text{m m}^{-1} \cdot ^\circ\text{C}^{-1}$ to center the specimen in the furnace and to fix the specimen to mechanical ground.

6.1.2 *Flexure Fixture*, of inert, low expansivity-coefficient of expansion material $<20 \mu\text{m m}^{-1} \cdot ^\circ\text{C}^{-1}$, to support the test specimen in a three-point bending mode (see Fig. 1).

6.1.3 *Rigid Knife Edge Compression Probe*, of inert, low expansivity-coefficient of expansion material $<20 \mu\text{m m}^{-1} \cdot ^\circ\text{C}^{-1}$ that contacts the specimen with an applied compression force (see Fig. 1).

6.1.4 *Deflection Sensing Element*, having a linear output over a minimum range of 5 mm to measure the displacement of the rigid compression probe (see 6.1.3) to within $\pm 0.1 \mu\text{m}$.

6.1.5 *Programmable Weight or Force Transducer*, to generate a constant force ($\pm 2.5\%$) between at least 0.01 N to 1.0 N, that is applied to the specimen through the rigid compression probe (see 6.1.3).

6.1.6 *Temperature Sensor*, that can be positioned reproducibly in close proximity to the specimen to measure its temperature within the range between 25 °C and 300 °C readable to ± 0.1 °C.

6.1.7 *Temperature Programmer and Furnace*, capable of temperature programming the test specimen from ambient to 300 °C at a linear rate of at least 2 ± 0.1 °C/min.

6.1.8 *Means of Providing a Specimen Environment*, of inert gas at a purge rate of 50 mL/min $\pm 5\%$.

NOTE 2—Typically, inert purge gases that inhibit specimen oxidation are 99.9+ % pure nitrogen, helium or argon. Dry gases are recommended for all experiments unless the effect of moisture is part of the study. The purge gas used for the test specimen ~~should~~shall be the same as that used during calibration.

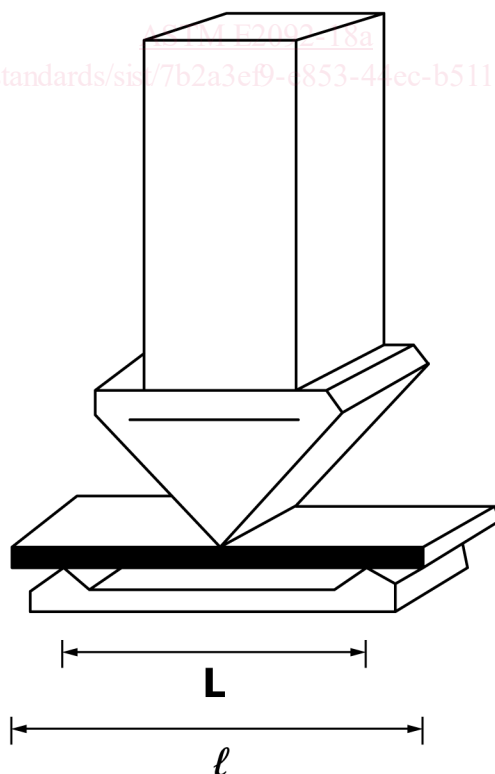

FIG. 1 Flexure Support Geometry

6.1.9 *Data Collection Device*, to provide a means of acquiring, storing, and displaying measured or calculated signals, or both. The minimum output signals required for a thermomechanical analyzer are dimension ion change, temperature and time.

6.1.10 While not required, it is convenient to have a data analysis device, that will perform and display the calculations of this standard.

6.2 Micrometer, calipers, film gage or other length-measuring device capable of measuring lengths of 0.01 mm to 20 mm with a precision of readable to within ± 0.001 mm.

7. Hazards

7.1 Toxic or corrosive effluents, or both, may be released when heating some materials and could be harmful to personnel and to apparatus.

7.2 Because the specimen size is small, care must be taken to ensure that each specimen is homogeneous and representative of the sample as a whole.

8. Sampling

8.1 The specimens may be cut from sheets, plates, or molded shapes, or may be molded to the desired finished dimensions.

8.2 The specimens used in this test method are ordinarily in the form of rectangular beams with aspect ratios of 1: 3: 10 for thickness or specimen depth (d), width (b) and length (l), depending upon the modulus of the sample and length of the support span (L).

NOTE 3—Other specimen and support dimensions may be used but care must be taken that the support length to specimen thickness ratio (L/d) be greater than 10.

NOTE 4—The specimen shall be long enough to allow overhanging on each end of at least 10 % of the support span, that is, $l \geq 1.2 L$.

NOTE 5—The overhang shall be sufficient to prevent the specimen from slipping from the supports.

8.3 This test method assumes that the material is isotropic. Should the specimen be anisotropic, such as in reinforced composites, the direction of the reinforcing agent shall be reported relative to the specimen dimensions.

9. Calibration

9.1 Calibrate the temperature display of the apparatus according to Test Method E1363 using a heating rate of $2\text{ }^{\circ}\text{C}/\text{min} \pm 0.1\text{ }^{\circ}\text{C}/\text{min}$.

9.2 Calibrate the deflection (length change) display of the apparatus according to the instrument manufacturer's instructions (see Test Method E2113).

9.3 Calibrate the mechanism for applying force to the test specimen according to the instrument manufacturer's instructions (see Test Method E2206).

10. Procedure

10.1 Measure the test length (L) of the test specimen as the distance between the two support points of the flexure support geometry to three significant figures (see Fig. 1).

10.2 Measure the width (b) and thickness (d) of the test specimen to three significant figures (see Fig. 2).

10.3 Select the stress (S) to be applied to the test specimen. This value is typically 0.455 (Method A) or 1.82 MPa (Method B) to correspond with the values used in Test Method D648.

NOTE 6—Other values may be used but shall be reported.

10.4 Select the strain (r) to be used to identify the heat distortion temperature.

NOTE 7—This value is typically 2.0 mm/m (0.20 %) to correspond with the values used in Test Method D648.

10.5 Using Eq 1, calculate to three significant figures the force (F) to be applied to the test specimen.

10.6 Using Eq 3, calculate to three significant figures the deflection (D) to be used as the experimental endpoint.

10.7 Center the specimen on the supports, with the long axis of the specimen perpendicular to the loading nose and supports (see Fig. 1).

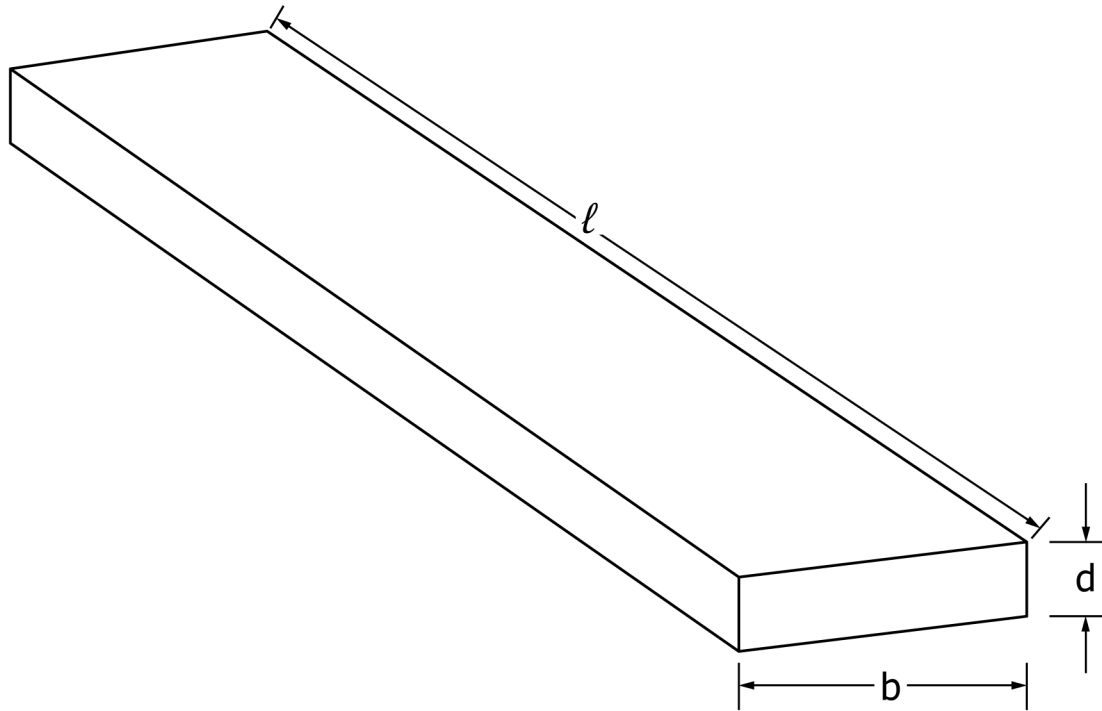

FIG. 2 Test Specimen Geometry

NOTE 8—The typical rectangular test beam is tested flatwise on the support span, with the applied force through its thinnest dimension.

10.8 Set initial experimental conditions by placing the test specimen into flexure support, loading the compression probe onto the center of the test specimen in the three-point bending mode with the force calculated in 10.5. Set the deflection-axis signal to be zero at ambient temperature.

10.9 Program the temperature from ambient temperature at $2\text{ }^{\circ}\text{C}/\text{min} \pm 0.1\text{ }^{\circ}\text{C}/\text{min}$ until the deflection, $D \pm 10\%$, determined in 10.6, is obtained while recording specimen deflection and temperature. Once the deflection value is achieved, terminate the temperature program and remove the load from the test specimen. Cool the apparatus to ambient temperature.

NOTE 9—Should the approximate distortion temperature of the material be known, the temperature program might be started at an elevated temperature that shall be at least $50\text{ }^{\circ}\text{C}$ below the anticipated distortion temperature.

10.10 Perform a baseline determination similar to section 10.9 except that the test specimen is the inverted flexure fixture.

NOTE 10—This step measures the deflection of the rigid specimen holder, flexure fixture and rigid knife edge compression probe.

10.11 For ease of interpretation, display the thermal curves from sections 10.9 and 10.10 with deflection displayed on the Y-axis and temperature on the X-axis as illustrated in Fig. 3, both axes set to the same scale sensitivity.

10.12 Using the same Y-axis scale sensitivity, subtract the baseline curve from 10.11 from the test specimen curve from 10.9.

10.13 The distortion temperature is taken as the temperature at which the test specimen achieves a distortion of the value of D from the initial condition in the baseline subtracted curve of 10.12.

11. Calculation

11.1 Calculate force value as follows:

$$F = (2 S b d^2)/(3 L) \quad (1)$$

where:

- F = force, N,
- S = stress, MPa,
- b = sample width, mm,
- d = sample thickness, mm, and
- L = length of the flexure fixture support span, mm.

11.1.1 As an example, if:

$$S = 0.455\text{ MPa,}$$