



Designation: ~~D3370~~—~~10~~ D3370 – 18

Standard Practices for ~~Sampling Water from Closed Conduits~~ Flowing Process Streams¹

This standard is issued under the fixed designation D3370; the number immediately following the designation indicates the year of original adoption or, in the case of revision, the year of last revision. A number in parentheses indicates the year of last reapproval. A superscript epsilon (ϵ) indicates an editorial change since the last revision or reapproval.

This standard has been approved for use by agencies of the U.S. Department of Defense.

1. Scope

1.1 These practices cover the equipment and methods for sampling water from closed conduits such as process streams at power stations for chemical, physical, microbiological, and radiological analyses. It does not cover specialized equipment required for and unique to a specific test or method of analysis. The following are included:

	<u>Sections</u>		<u>Sections</u>
<u>Practice A—Grab Samples</u>	<u>9 – 17</u>	—Practice A—Grab Samples	9—17
<u>Practice B—Composite Samples</u>	<u>18 – 23</u>	—Practice B—Composite Samples	18—23
<u>Practice C—On-Line Sampling</u>	<u>24 – 29</u>	—Practice C—On-Line Sampling	24—29

1.2 For information on specialized sampling equipment, tests or methods of analysis, reference should be made to Volumes 11.01 and 11.02 of the *Annual Book of ASTM Standards*, relating to water.

1.3 The values stated in SI units are to be regarded as standard. ~~The values listed given in parenthesis are for information only. Parentheses are mathematical conversions to inch-pound units that are provided for information only and are not considered standard.~~

1.4 *This standard does not purport to address all of the safety concerns, if any, associated with its use. It is the responsibility of the user of this standard to establish appropriate safety, health, and environmental practices and determine the applicability of regulatory limitations prior to use.* For specific hazards statements, see 8.3 and 13.4.

1.5 *This international standard was developed in accordance with internationally recognized principles on standardization established in the Decision on Principles for the Development of International Standards, Guides and Recommendations issued by the World Trade Organization Technical Barriers to Trade (TBT) Committee.*

2. Referenced Documents

2.1 ASTM Standards:²

- [A106/A106M Specification for Seamless Carbon Steel Pipe for High-Temperature Service](#)
- [A179/A179M Specification for Seamless Cold-Drawn Low-Carbon Steel Heat-Exchanger and Condenser Tubes](#)
- [A269 Specification for Seamless and Welded Austenitic Stainless Steel Tubing for General Service](#)
- [A335/A335M Specification for Seamless Ferritic Alloy-Steel Pipe for High-Temperature Service](#)
- [D1066 Practice for Sampling Steam](#)
- [D1129 Terminology Relating to Water](#)
- [D1193 Specification for Reagent Water](#)
- [D3648 Practices for the Measurement of Radioactivity](#)
- [D3694 Practices for Preparation of Sample Containers and for Preservation of Organic Constituents](#)

¹ These practices are under the jurisdiction of ASTM Committee D19 on Water and are the direct responsibility of Subcommittee D19.03 on Sampling Water and Water-Formed Deposits, Analysis of Water for Power Generation and Process Use, On-Line Water Analysis, and Surveillance of Water
Current edition approved Dec. 1, 2010/Dec. 15, 2018. Published December 2010/January 2019. Originally approved in 1974. Last previous edition approved in 2009/2010 as ~~D3370—09~~ D3370—10. DOI: ~~10.1520/D3370-10~~ 10.1520/D3370-18.

² For referenced ASTM standards, visit the ASTM website, www.astm.org, or contact ASTM Customer Service at service@astm.org. For *Annual Book of ASTM Standards* volume information, refer to the standard's Document Summary page on the ASTM website.

D3856 Guide for Management Systems in Laboratories Engaged in Analysis of Water

D4453 Practice for Handling of High Purity Water Samples

D4840 Guide for Sample Chain-of-Custody Procedures

D4841 Practice for Estimation of Holding Time for Water Samples Containing Organic and Inorganic Constituents

D5540 Practice for Flow Control and Temperature Control for On-Line Water Sampling and Analysis

3. Terminology

3.1 ~~Definitions—Definitions:~~ For definitions used in these practices, refer to Terminology ~~D1129~~.

3.1.1 For definitions of terms used in this standard, refer to Terminology D1129.

3.2 *Definitions of Terms Specific to This Standard:*

3.2.1 *back-pressure regulator, n*—a device designed to maintain a constant pressure upstream of itself (variable or fixed back pressure regulators are available) to maintain constant flow in analyzers in on-line sampling.

3.2.1.1 *Discussion—*

Contemporary designs of back-pressure regulators provide excellent sensitivity to pressure ~~variations~~variations. They require less space, have fewer maintenance problems, and reduce sample-contamination potential.

3.2.2 *composite sample, n*—a series of grab samples integrated into a single sample or a sample collected at specific time intervals and integrated into a single sample.

3.2.2.1 *Discussion—*

The goal of a composite sample is to characterize a process-weighted average in proportion to process parameters.

3.2.3 *grab sample, n*—a single sample from a process stream (flowing) or from a source of confined-geometry (stagnant) withdrawn at a specific time.

3.2.3.1 *Discussion—*

The goal of withdrawing a grab sample is to obtain a small portion of the process stream or confined geometry source in order to characterize the entire system.

3.2.4 *pressure reducer, n*—a device designed to reduce pressure, and therefore control flow, of sample to a pressure level where regulation is easily achieved.

3.2.4.1 *Discussion—*

This device shall be located downstream of the cooled sample where cooling is required.

3.2.5 *sample cooler, n*—a small heat exchanger designed to provide primary or secondary cooling, or both, of sampling streams of water or steam.

3.2.6 *variable rod in tube orifice, n*—for high pressure samples, a type of pressure reducer that uses a retractable tapered rod inside a reamed tube to provide a variable orifice for pressure reduction. The rods are parallel with the sample flow. This design eliminates wear of the orifice and provides variable pressure-reduction and flow.

4. Summary of Practices

4.1 These practices include three procedures for sample collection. The first is for the collection of a grab sample of water at a specific site representing conditions only at the time of sampling. Grab sampling is the only procedure suitable for bacteriological analysis and some radiological test procedures.

4.2 The second practice is for collection of a composite sample at a specific site, portions of which are collected at varied time intervals. Alternatively, the composite may consist of portions collected at various sites or a combination of both site and time variables.

4.3 The third practice provides a continuously flowing sample from one or more sampling sites, suitable for on-line analyzers or for collecting grab samples from a continuously flowing sample stream.

5. Significance and Use

5.1 The goal of sampling is to obtain for analysis a portion of the main body of water that is representative. The most critical factors necessary to achieve this are points of sampling, and materials selection, system design, time of sampling, frequency of sampling, and proper procedures to maintain the integrity of the sample prior to analysis.

5.2 Homogeneity of the process to be sampled is frequently lacking, necessitating multiple-point sampling. If it is impractical to utilize a most-representative sampling point, it may be practical to determine and understand interrelationships so that results obtained at a minimum number of points may be used to characterize the system.

5.3 Samples collected from a single point in a system are always recognized as being non-representative to some degree. For this reason, total representativeness of samples cannot be a prerequisite to the selection of a sampling point. The degree of representativeness of the sample shall be assessed and the assessment made a part of the permanent record. This will prevent an artificial degree of accuracy from being assigned to the data derived from tests on the sample.

5.4 The samples shall be of sufficient volume and shall be taken frequently enough to permit reproducibility of testing requisite for the desired objective, as required by the method of analysis to be used.

5.5 Laboratories or facilities conducting water sampling should be in compliance with Guide [D3856](#).

6. Interferences

6.1 If chemicals are injected or other streams are introduced into the medium to be sampled, the sample collection point should be placed far enough downstream to ensure a completely mixed sample. Assuming turbulent flow (for example, a Reynolds number of at least 4000), locating the sample collection point an equivalent length of 25 diameters downstream of the chemical injection point is considered acceptable. An equivalent length of 50 diameters is recommended for laminar flow.

6.2 The sampling of high-purity water requires special consideration. Contact with any material other than the original container subjects the sample to possible contamination or alteration. This includes contact with air. Additional requirements are given in Practice [D4453](#).

7. Materials and Apparatus

7.1 Sample Lines:

7.1.1 *General*—Sample lines should be designed so that the sample is representative of the source. They shall be as short as feasible and of the smallest practicable bore to facilitate flushing, minimize conditioning requirements, reduce lag time and changes in sample composition, and provide adequate velocity and turbulence. The lines shall have sufficient strength to prevent structural failure. The designer is responsible for ensuring that applicable structural integrity requirements are met. Small tubing is vulnerable to mechanical damage and should be protected.

7.1.1.1 Traps and pockets in which solids might settle shall be avoided, since they may be partially emptied with changes in flow conditions and may result in sample contamination. Sample tubing shall be shaped so that sharp bends, dips, and low points are avoided, thus preventing particulates from collecting. Expansion loops or other means shall be provided to prevent undue buckling and bending when large temperature changes occur. Such buckling and bending may damage the lines and allied equipment. Routing shall be planned to protect sample lines from exposure to extreme temperatures.

NOTE 1—Studies **(1-5)**³ on particle transport in sampling lines have indicated that sample velocity rate and stability are important factors in determining deposition and erosion rates on sample tube walls and time required to reach and maintain equilibrium. Although limited, other work has also noted effects of sorption of dissolved species within tube wall deposits. Velocities near 1.8 m/s (6 f/s) seem to optimize these factors, but, other velocities can provide acceptable results. Sample velocity should be considered as a key design issue along with type of sample, lag time, pressure drop, new or existing sample lines, etc. when determining sample flow rates. Maintaining the selected velocity is necessary to achieve sample representivity.

7.1.2 *Materials*—The material from which the sample lines are made shall conform to the requirements of the applicable specifications as follows:

³ The boldface numbers in parentheses refer to the list of references at the end of this standard.

ASTM Designation

<u>Pipe (seamless carbon steel for high-temperature —service)</u>	Specification A106/A106M
<u>Pipe (seamless carbon steel for high-temperature service)</u>	Specification A106/A106M
<u>Pipe (seamless ferritic alloy steel for high-temperature —service)</u>	Specification A335/A335M
<u>Pipe (seamless ferritic alloy steel for high-temperature service)</u>	Specification A335/A335M
<u>Tubing (seamless carbon steel for high-temperature —service)</u>	Specification A179/A179M
<u>Tubing (seamless carbon steel for high-temperature service)</u>	Specification A179/A179M
<u>Tubing (seamless or welded alloy steel for high-temperature —service)</u>	Specification A269
<u>Tubing (seamless or welded alloy steel for high-temperature service)</u>	Specification A269
<u>Tubing, Plastic (polyethylene), or equivalent —non-leaching inert materials</u>	
<u>Tubing, Plastic (polyethylene), or equivalent non-leaching inert materials</u>	

Carbon steel pipe or tubing may be satisfactory for sampling lines where levels of contaminants in the sample are high, or sample constituents require it. For sampling high-purity waters or corrosive waters, the sampling lines shall be made of stainless steel that is at least as corrosion resistant as 18 % chromium, 8 % nickel steel (AISI 304 or 316 austenitic stainless steels are commonly used **(6)**).

NOTE 2—Plastic tubing should be avoided where low values of dissolved oxygen are to be measured since atmospheric gases may diffuse through the tubing and cause an analytical bias. The selection of the sample line material should be based on the parameters of interest.

7.2 Valves and Fittings:

7.2.1 *Materials*—Valve and fitting materials should be compatible with the sample and the sample line material selected. AISI 316 austenitic stainless steel is commonly used. Pressure and temperature ratings should be selected based on the specific service of the valve/fitting.

7.2.2 *Isolation Valves*—At least one shut off valve (commonly referred to as a root valve) shall be placed immediately after the point from which the sample is withdrawn so that the sample line may be isolated when desired. For safety purposes, an isolation valve should be placed at the sample cooler inlet (if used) and be rated in accordance with the pressure and temperature of the sample source.

7.2.3 *Pressure Reducers*—The pressure reducer, in combination with properly sized sample lines, is the primary component necessary to control the sample flow at the rates required to give the most representative sample (see **Note 1**). Flow control is accomplished at the same time sample pressure is reduced.

7.2.3.1 For samples equal to or greater than 500 psig (3447 kPa), the pressure reducer shall be a rod-in-tube type orifice or capillary (variable or fixed). Variable rod-in-tube devices are recommended since they offer two advantages: (a) they are capable of varying the pressure drop and, therefore, the flow; and (b) they are cleanable in place (exercising the position of the tapered rod in the tube). Forepressure regulators are not recommended for large pressure reductions because of susceptibility to erosion, plugging, and wire drawing of the stem or seat.

7.2.3.2 For samples less than 500 psig (3447 kPa), the pressure reducer shall be a needle valve.

7.2.4 *Pressure Regulators*—Since most on-line analyzers are flow sensitive, as well as temperature sensitive, the flow rate in the branch circuits shall also be controlled to ensure repeatable analytical results. This is achieved by establishing a constant pressure zone where the sample line feeds the analyzer branch lines. See Practice **D5540** for additional information. Because of the relationship of pressure and flow, a zone of constant pressure will ensure that each analyzer fed from this zone gets a constant flow rate independent of actions taken in the other branch lines while maintaining constant flow in the main sample line. Maintaining constant flow is also essential in regularly monitored grab samples. Two methods are available to achieve this constant pressure zone in conjunction with the upstream pressure reducer: (1) back pressure regulator (fixed or variable) or (2) head cup. Using a forepressure regulator without a back pressure regulator or head cup is not recommended. A forepressure regulator alone will not provide a constant sample line flow. Flow changes in the branch lines below the regulator result in the forepressure regulator closing or opening to maintain the analyzer inlet pressure thereby changing the main sample line flow and disrupting the representivity of the sample from its source.

7.2.4.1 Use of a back pressure regulator is the preferred method to achieve the constant pressure zone. Total sample flow is established using the primary pressure reducer with all flow going through the back pressure regulating valve to drain, recovery, or for grab sample. The regulating valve establishes a fixed pressure at the valve inlet. Branch lines to each analyzer are connected to this fixed pressure zone. When flow is initiated to an analyzer, the back pressure regulator will close slightly to maintain the pressure at the regulator inlet. Similarly, when flow to an analyzer is shut off, the regulator will open to accommodate the increased flow. Since the pressure at the branch connections to the other analyzers is maintained constant, their flow is not affected by changes of flow to other analyzers.

7.2.5 *Other Valves*—Blowdown/flushing valves may be used to purge sample lines that are not in continuous service and can be located prior to or after the roughing or primary sample cooler. Other valves should be selected based on specific requirements, for example, analyzer flow metering, secondary isolation, grab sampling, etc. In sampling systems with on-line analyzers, selecting a ball valve for grab sample use without a flow metering valve in series with it can starve the constant pressure zone created by the back pressure regulator/head cup and disrupt sample flow. Systems shall be provided with a method to protect components from overpressurization. Acceptable methods include suitable back pressure regulator with built in relieving capacity, head cup, or suitable relief valve.

7.2.6 *Fittings*—If feasible, bends rather than fittings should be used to change direction of sample tubing. Compression or socket weld fittings can be selected for sample lines. Because improperly welded joints are susceptible to plugging by suspended solids, compression fittings are preferred. The ends of cut tubes shall be ream cut to restore the full bore of the pipe diameter. If not installed properly, both socket weld and compression fittings can include fine annuli between tube and fittings that may hold contaminants.

7.3 *Sample Cooler or Condenser:*

7.3.1 High efficiency sample coolers or condensers used for primary temperature reduction/condensation shall be capable of normally reducing the incoming sample temperature to within 5°F (2.8°C) of the cooling water inlet temperature for water samples and 10°F (5.6°C) of the cooling water inlet temperature for steam samples at sample flows that are sufficient to provide a representative sample (refer to 7.1.1). Cooling water requirements should be as low as possible but shall not exceed 12 g/m (2.7 m³/h) per cooler except for very large sample flows (1 g/m (0.3 m³/h)). Sample coolers used for secondary cooling shall be capable of a 1°F (0.5°C) approach to the chilled water temperature when the primary cooler is specified as detailed above. The tube through which the sample will flow shall be one continuous piece and shall extend completely through the cooler without deformation so there is no possibility of sample contamination or dilution from the cooling water. The tube shall be of sufficient strength to withstand the full pressure and temperature of the fluid being sampled.

7.3.2 The cooler or condenser tube shall be made of stainless steel that is at least as corrosion resistant as 18 % chromium, 8 % nickel steel. Specific water chemistry could dictate different materials for improved corrosion resistance, for example, Alloy 625 for high chlorides. The diameter of the tube shall be as small as practicable based on representative sample flows so that storage within the coil is low and the time lag of the sample through the cooler is minimal.

7.3.3 Fig. 1 and Fig. 2 show typical sample coolers. Fig. 1 is a helical coil heat exchanger with removable one-piece shell type sample cooler. Fig. 2 is a double concentric helical coil, or tube within a tube type sample cooler. The portion of the sample cooler (shell or outer tube) containing the cooling water should provide for adequate cooling water velocity to achieve required sample cooler efficiency as noted above and be made of material that is corrosion resistant to the cooling water in use. Materials that have corrosion resistance to the ambient atmosphere around the sample cooler itself should also be considered in order to avoid exterior corrosion, pitting, etc., on the sample cooler.

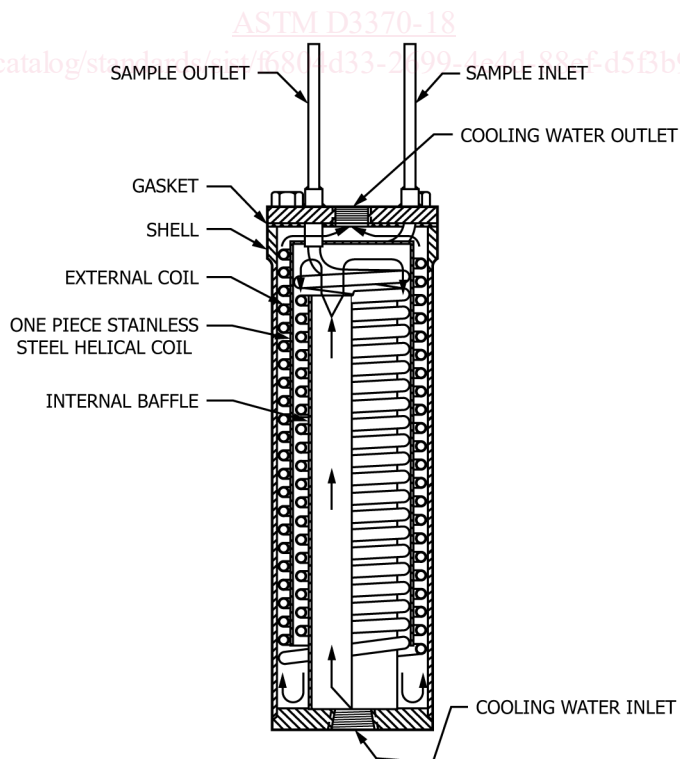

FIG. 1 Helical Coil Heat Exchanger with Removable Shell

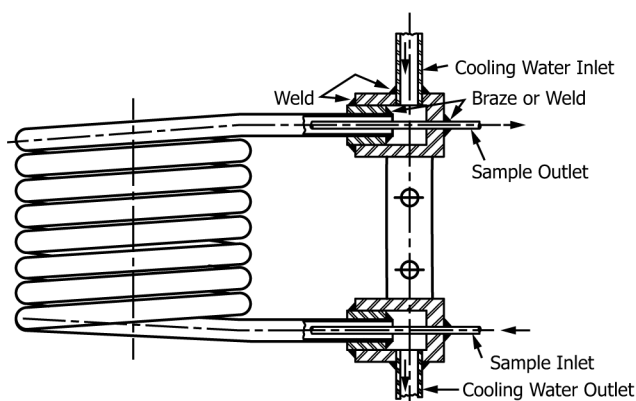

FIG. 2 Double-Tube Helical Coil Heat Exchanger

NOTE 3—The scaling/fouling tendencies of the cooling water available should be given careful consideration when selecting a sample cooler or condenser. Water that is extremely hard or contains considerable slime or algae or suspended solids may cause rapid fouling of the cooling water side of the cooler, such that its efficiency may be seriously impaired. If it is necessary to use such a cooling water, the sample cooler should be one that can be cleaned readily and effectively with the least possible delay, for example, submerged helical coil in shell sample cooler (see Fig. 1). Concentric (tube in tube) type coolers (see Fig. 2) are subject to plugging and fouling.

7.4 *Flow Meters*—A visual means of reading main and branch sample line(s) flow shall be used. Rotameters or other mechanical or electronic flow measuring devices are recommended. This is the only way to ensure that the sample is flowing at a velocity that assures a representative sample. Refer to 7.1.1.

7.5 *Sample Filters*—Use of sample filters to remove suspended solids such as metal oxides can dramatically change the analytical results. Metal oxides react with other chemicals in water and steam (6) and change the ratio of the total/dissolved chemicals. Use of sample filters should, therefore, be evaluated with respect to analytical and control requirements.

7.6 *Pumps*—Withdrawing of a water sample under subatmospheric pressure may require the use of pumps. Small centrifugal pumps with casing or suction side vent to the source, magnetically coupled gear pumps, or diaphragm pumps may be used. Pumps employing built in filters should have them removed. The suction sampling line shall be sloped downward over its entire length without pockets to avoid gas binding. Consideration shall be given to possible contamination of the sample due to pump material depending on the particular constituents to be analyzed. Also, consideration shall be given to ensure that the pump is designed to handle low net positive suction head (NPSH) which is typically seen in subatmospheric samples.

7.7 *Sample Probes, Nozzles, and Isokinetic Sampling:* <https://standards.iteh.ai/catalog/standards/sist/804d33-2699-4e4d-88ef-d5fb9bfa800/astm-d3370-18>

7.7.1 Multiport and single-port nozzles can be used to obtain representative samples from process streams. Liquid samples may be extracted from the side of horizontal piping runs. Single-port taps are adequate if sufficient velocity is maintained to avoid deposition, whereas multiport nozzles are recommended for obtaining samples containing suspended matter. Multiport nozzles can be provided to extend across a pipe diameter to obtain an average sample of a cross section. Fig. 3 illustrates a single-port sampling nozzle. The impact of sample probe failure on process equipment damage should be considered.

7.7.2 Because of varying sizes and densities of particles, samples shall be withdrawn from a flowing stream in a manner that the velocity of the sample in the nozzle tip is equal to the velocity of the fluid approaching the nozzle. If the velocity of the sample in the nozzle is greater than that of the fluid approaching the nozzle, the concentration of particles will be less than that in the process fluid, whereas the opposite occurs when the fluid velocity in the nozzle is less than that approaching the nozzle. When the velocity of the fluid in the nozzle is equal to that of the fluid approaching the nozzle, isokinetic sampling is provided. Isokinetic sampling is required when two phases which have different densities are present and is recommended for corrosion product sampling.

7.7.3 Caution should be used in designing sample probes and nozzles. Corrosion product or sediment (crud) deposits are greater on tees than on other tubes, and deposition is linearly proportional to the length of sample tube (7). Thus, sample collection points should be as close to sample probes and nozzles as practicable.

7.8 *Degassers*—Degassers shall be made of corrosion-resistant materials similar to materials described in 10.1. The degassers shall be designed to take the full flow required for representative sampling as described in Practice D1066. The piping ahead of the degasser shall be arranged so that none of the sample is diverted from the degasser.

7.9 *Sample Containers*—Sample containers shall be made of materials that will not contaminate the sample and, before use, shall be cleaned thoroughly to remove all extraneous surface dirt. Chemically resistant glass and polyethylene are suitable materials for the containers. The closures for the sample containers shall be glass stoppers that have been thoroughly washed, or plastic caps with suitable liners. See Practices D3694 and D4453 for additional information. Sample containers shall be made of materials that will not contaminate the sample and shall be cleaned thoroughly before use to remove all extraneous surface contamination. The