



Designation: **D3461 – 14 D3461 – 18**

Standard Test Method for Softening Point of Asphalt and Pitch (Mettler Cup-and-Ball Method)¹

This standard is issued under the fixed designation D3461; the number immediately following the designation indicates the year of original adoption or, in the case of revision, the year of last revision. A number in parentheses indicates the year of last reapproval. A superscript epsilon (ϵ) indicates an editorial change since the last revision or reapproval.

1. Scope*

1.1 This test method covers the determination of the softening point of asphalt and pitch in the range from 50 °C to 180 °C by the cup-and-ball apparatus, and gives results comparable to those obtained by Test Method **D36**.

NOTE 1—If the softening point of asphalt by this Mettler cup-and-ball method fails to meet specified requirements, tests may be rerun using the Test Method **D36** (ring-and-ball) softening point apparatus as a referee method.

1.2 *This standard does not purport to address all of the safety concerns, if any, associated with its use. It is the responsibility of the user of this standard to establish appropriate safety, health, and environmental practices and determine the applicability of regulatory limitations prior to use.*

1.3 *This international standard was developed in accordance with internationally recognized principles on standardization established in the Decision on Principles for the Development of International Standards, Guides and Recommendations issued by the World Trade Organization Technical Barriers to Trade (TBT) Committee.*

2. Referenced Documents

2.1 *ASTM Standards:*²

A314 Specification for Stainless Steel Billets and Bars for Forging

D36 Test Method for Softening Point of Bitumen (Ring-and-Ball Apparatus)

D140 Practice for Sampling Asphalt Materials

D4296 Practice for Sampling Pitch

3. Summary of Test Method

3.1 In this test method the softening point is defined as the temperature at which the specimen, suspended in a cylindrical cup with a 6.5 mm hole in the bottom and with a lead ball, 8 mm in diameter, centered on top of the sample in the cup, flows downward a distance of 19 mm to interrupt a light beam, as the sample is heated at a linear rate in air.

4. Significance and Use

4.1 Asphalt and pitch do not go through a solid-liquid phase change when heated, and therefore do not have true melting points. As the temperature is raised, they gradually soften or become less viscous. For this reason, the determination of the softening point must be made by an arbitrary, but closely defined, method if the test values are to be reproducible.

4.2 This test method is useful in determining the consistency as one element in establishing the uniformity of shipments or sources of supply.

5. Apparatus

5.1 A METTLER TOLEDO dropping point cell³ can be used to determine softening points by this test method. These commercially available instruments consist of a control unit with a digital temperature indicator with furnace built in or attached,

¹ This test method is under the jurisdiction of ASTM Committee **D02** on Petroleum Products, Liquid Fuels, and Lubricants and is the direct responsibility of Subcommittee **D02.05** on Properties of Fuels, Petroleum Coke and Carbon Material.

Current edition approved Oct. 1, 2014; Dec. 1, 2018. Published November 2014; January 2019. Originally approved in 1976. Last previous edition approved in 2014 as **D3461 – 97D3461 – 14**, (2012); DOI: 10.1520/D3461-14.10.1520/D3461-18.

² For referenced ASTM standards, visit the ASTM website, www.astm.org, or contact ASTM Customer Service at service@astm.org. For *Annual Book of ASTM Standards* volume information, refer to the standard's Document Summary page on the ASTM website.

³ The sole source of supply of the apparatus known to the committee at this time is available from Mettler-Toledo, LLC., 1900 Polaris Pkwy, Columbus, OH 43240, www.mt.com. If you are aware of alternative suppliers, please provide this information to ASTM International Headquarters. Your comments will receive careful consideration at a meeting of the responsible technical committee,¹ which you may attend.

*A Summary of Changes section appears at the end of this standard

sample cartridges, and accessories. The control unit automatically regulates the heating rate of the furnace. The softening point is indicated on the readout, and the heating program stopped, when the sample flow triggers the softening point detection. A general view of the components of the METTLER TOLEDO softening point instrument is shown in Fig. 1 (old instrument) and Fig. 2 (new instrument).

5.1.1 *Integrated or Separate Control Unit*—The control unit shall provide a continuous, linear temperature increase from 25 °C to 250 °C at a rate of 2 °C/min. A digital readout shall indicate the temperature to 0.1 °C throughout.

5.1.2 *Integrated or Separate Furnace Unit*—The furnace unit shall be capable of heating one or two sample cup assemblies, as described in 5.1.3, at a linear rate of 2 °C ± 0.3 °C/min. It shall include a sensing system capable of detecting the softening point with a precision of 0.1 °C.

5.1.3 *Sample Cup Assembly*—A cup of chromium-plated brass, or of aluminum, or of stainless steel conforming to the requirements for Type 303 (UNS S30300) stainless steel as prescribed in Specification A314, with the dimensions shown in Fig. 3. It shall be placed in the assembly so that the pitch sample softening point will be detected when it has flowed down a distance of 19 mm.

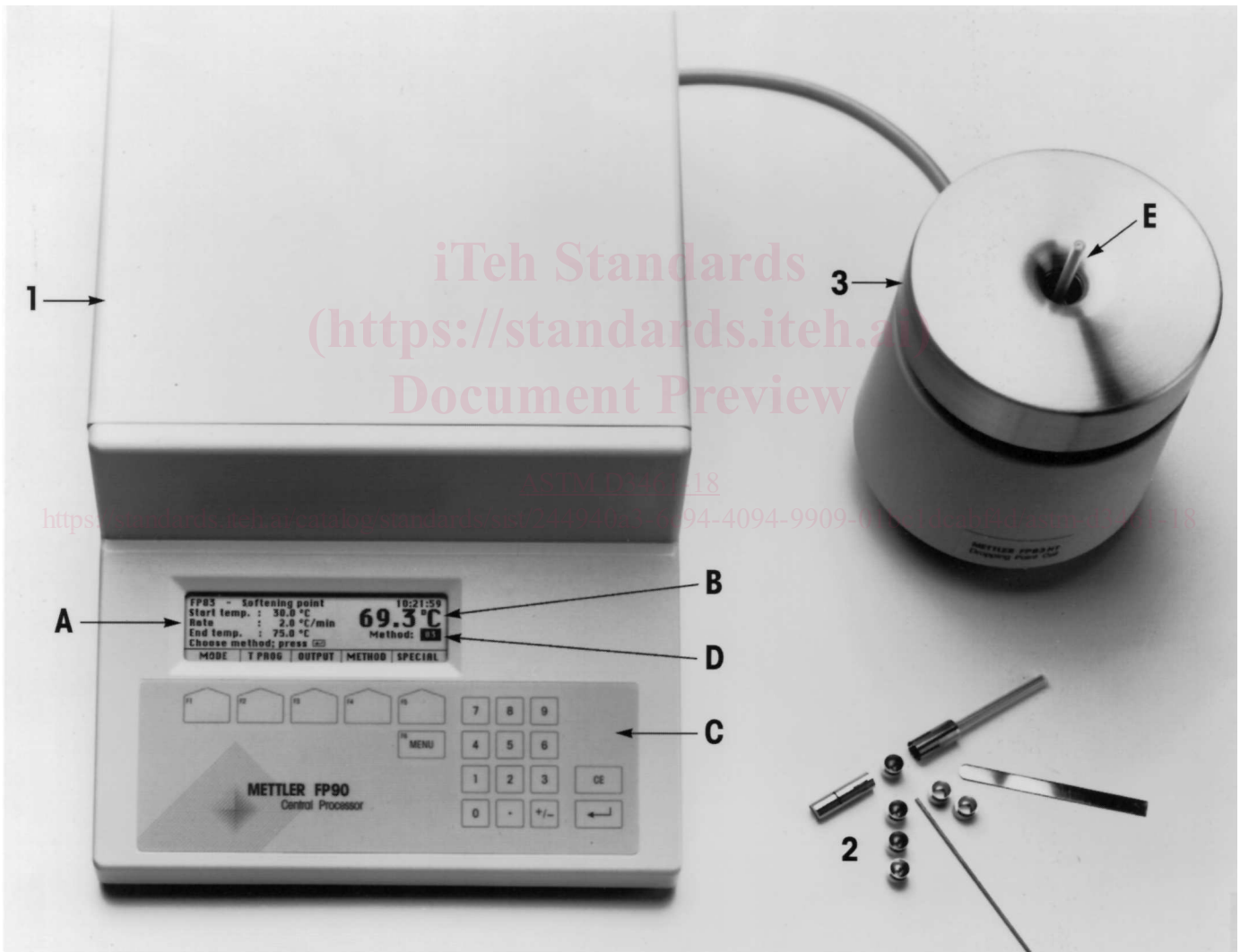

General View of the METTLER TOLEDO FP90/FP83HT

- | | |
|--|-------------------------------|
| 1 Control and evaluation unit | 2 Cartridges with accessories |
| A LCD with guide for operator | 3 Measuring cell FP83HT |
| B Temperature display | E Sample holder |
| C Keyboard with function keys F1 to F6 | |
| D Selected method number | |

FIG. 1 General View of the METTLER TOLEDO FP90 Control Unit with Heater FP83HT



FIG. 2 General View of the METTLER TOLEDO DP70

<https://standards.iteh.ai/catalog/standards/sist/244740a5-0c74-4074-9707-01bc1dcabf4d/astm-d3461-18>

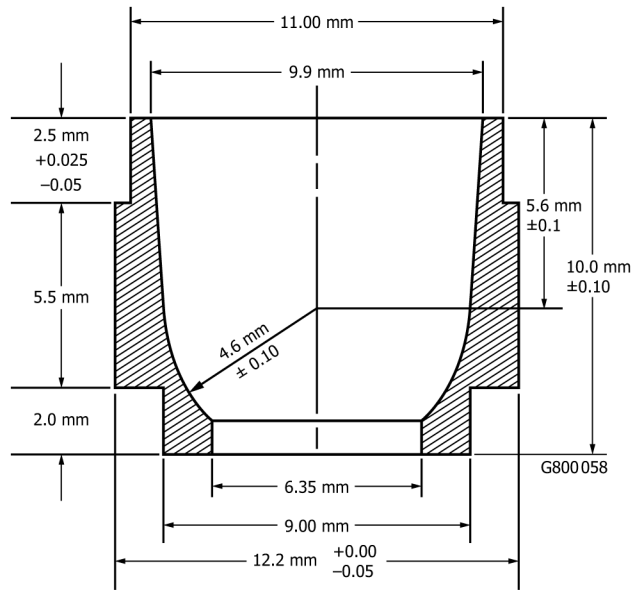

FIG. 3 Specimen Cup

5.1.4 *Lead Ball*—A lead ball weighing ~~3.20 g ± 0.10 g~~ between 3.00 g and 3.30 g. A 32-caliber lead shot is suitable for this purpose.

6. Reagents

6.1 *Xylene*, industrial grade.

7. Calibration of METTLER TOLEDO Apparatus

7.1 This step, required only occasionally, is designed to establish that the temperature indicated by the instrument is in agreement with a known standard. A special cup with a bottom orifice of 2.8 mm is used instead of the one prescribed for the testing of pitch.

7.2 *Reagent*—Use either analytical reagent or primary standard grade benzoic acid for the calibration. As this material is hygroscopic it must be stored in a tightly sealed container, and replaced with fresh material from a newly opened supply if hydration or other contamination is suspected.

iTeh Standards
(<https://standards.iteh.ai>)
Document Preview

[ASTM D3461-18](#)

<https://standards.iteh.ai/catalog/standards/sist/244940a3-6c94-4094-9909-01bc1dcabf4d/astm-d3461-18>