



Designation: D7653 – 18

# Standard Test Method for Determination of Trace Gaseous Contaminants in Hydrogen Fuel by Fourier Transform Infrared (FTIR) Spectroscopy<sup>1</sup>

This standard is issued under the fixed designation D7653; the number immediately following the designation indicates the year of original adoption or, in the case of revision, the year of last revision. A number in parentheses indicates the year of last reappraisal. A superscript epsilon ( $\epsilon$ ) indicates an editorial change since the last revision or reappraisal.

## 1. Scope

1.1 This test method employs an FTIR gas analysis system for the determination of trace impurities in gaseous hydrogen fuels relative to the hydrogen fuel quality limits described in SAE TIR J2719 (April 2008) or in hydrogen fuel quality standards from other governing bodies. This FTIR method is used to quantify gas phase concentrations of multiple target contaminants in hydrogen fuel either directly at the fueling station or on an extracted sample that is sent to be analyzed elsewhere. Multiple contaminants can be measured simultaneously as long as they are in the gaseous phase and absorb in the infrared wavelength region. The detection limits as well as specific target contaminants for this standard were selected based upon those set forth in SAE TIR J2719.

1.2 This test method allows the tester to determine which specific contaminants for hydrogen fuel impurities that are in the gaseous phase and are active infrared absorbers which meet or exceed the detection limits set by SAE TIR J2719 for their particular FTIR instrument. Specific target contaminants include, but are not limited to, ammonia, carbon monoxide, carbon dioxide, formaldehyde, formic acid, methane, ethane, ethylene, propane, and water. This test method may be extended to other impurities provided that they are in the gaseous phase or can be vaporized and are active infrared absorbers.

1.3 This test method is intended for analysis of hydrogen fuels used for fuel cell feed gases or for internal combustion engine fuels. This method may also be extended to the analysis of high purity hydrogen gas used for other applications including industrial applications, provided that target impurities and required limits are also identified.

1.4 This test method can be used to analyze hydrogen fuel sampled directly at the point-of-use from fueling station nozzles or other feed gas sources. The sampling apparatus

includes a pressure regulator and metering valve to provide an appropriate gas stream for direct analysis by the FTIR spectrometer.

1.5 This test method can also be used to analyze samples captured in storage vessels from point-of-use or other sources. Analysis of the stored samples can be performed either in a mobile laboratory near the sample source or in a standard analytical laboratory.

1.6 A test plan should be prepared that includes (1) the specific impurity species to be measured, (2) the concentration limits for each impurity species, and (3) the determination of the minimum detectable concentration for each impurity species as measured on the apparatus before testing.

1.7 The values stated in SI units are to be regarded as standard. No other units of measurement are included in this standard.

1.7.1 *Exception*—All values are based upon common terms used in the industry of those particular values and when not consistent with SI units, the appropriate SI unit will be included in parentheses after the common value usage (4.4, 7.8, 7.9, 10.5, and 11.6).

1.8 *This standard does not purport to address all of the safety concerns, if any, associated with its use. It is the responsibility of the user of this standard to establish appropriate safety, health, and environmental practices and determine the applicability of regulatory limitations prior to use.*

1.9 *This international standard was developed in accordance with internationally recognized principles on standardization established in the Decision on Principles for the Development of International Standards, Guides and Recommendations issued by the World Trade Organization Technical Barriers to Trade (TBT) Committee.*

## 2. Referenced Documents

- 2.1 *ASTM Standards*:<sup>2</sup>  
[D5287 Practice for Automatic Sampling of Gaseous Fuels](#)

<sup>1</sup> This test method is under the jurisdiction of ASTM Committee D03 on Gaseous Fuels and is the direct responsibility of Subcommittee D03.14 on Hydrogen and Fuel Cells.

Current edition approved Dec. 1, 2018. Published February 2019. Originally approved in 2010. Last previous edition approved in 2010 as D7653 – 10. DOI: 10.1520/D7653-18.

<sup>2</sup> For referenced ASTM standards, visit the ASTM website, [www.astm.org](http://www.astm.org), or contact ASTM Customer Service at [service@astm.org](mailto:service@astm.org). For *Annual Book of ASTM Standards* volume information, refer to the standard's Document Summary page on the ASTM website.

**D6348 Test Method for Determination of Gaseous Compounds by Extractive Direct Interface Fourier Transform Infrared (FTIR) Spectroscopy**

**D7606 Practice for Sampling of High Pressure Hydrogen and Related Fuel Cell Feed Gases**

2.2 *SAE Document*:<sup>3</sup>

**SAE TIR J2719 Informational Report on the Development of a Hydrogen Quality Guideline for Fuel Cell Vehicles**

2.3 *EPA Documents*:<sup>4</sup>

**EPA 40 CFR Protection of the Environment, Appendix B to Part 136 Definition and Procedure for the Determination of the Method Detection Limit**

**EPA 40 CFR Protection of the Environment, Appendix B to Part 60: Performance Specification 15 Performance Specification for Extractive FTIR Continuous Emissions Monitoring Systems in Stationary Sources**

### 3. Terminology

3.1 *Definitions of Terms Specific to This Standard*:

3.1.1 *analytical interference, n*—the physical effects of superimposing two or more light waves.

3.1.1.1 *Discussion*—Analytical interferences occur when two or more compounds have overlapping absorbance bands in their infrared spectra.

3.1.2 *analytical algorithm, n*—the method used to quantify the concentration of the target contaminants and interferences in each FTIR Spectrum.

3.1.2.1 *Discussion*—The analytical algorithm should account for the analytical interferences by conducting the analysis in a portion of the infrared spectrum that is the most unique for that particular compound.

3.1.3 *apodization, n*—a mathematical transformation carried out on data received from an interferometer to reduce the side lobes of the measured peaks.

3.1.3.1 *Discussion*—This procedure alters the instrument's response function. There are various types of transformation; the most common forms are boxcar, triangular, Happ-Genzel, and Norton-Beer functions.

3.1.4 *background spectrum, n*—the spectrum taken in the absence of absorbing species or sample gas, typically conducted using dry nitrogen or zero air in the gas cell.

3.1.5 *classical least squares (CLS), n*—common method of analyzing multicomponent infrared spectra by scaled absorbance subtraction, also referred to as K-Matrix.

3.1.6 *constituent, n*—component (or compound) found within a hydrogen fuel mixture.

3.1.7 *contaminant, n*—impurity that adversely affects the components within the fuel cell system or the hydrogen storage system.

3.1.8 *dry nitrogen (or dry N<sub>2</sub>), n*—nitrogen gas with a dew point at or below  $-60\text{ }^{\circ}\text{C}$ .

3.1.9 *dynamic calibration, n*—calibration of an analytical system using certified calibration gas standards that are diluted to known concentration.

3.1.10 *FCV, n*—Hydrogen fuel cell vehicle.

3.1.11 *Fourier Transform Infrared (FTIR), n*—typically refers to a type of infrared spectrometer which incorporates a Michelson interferometer to modulate the infrared radiation before probing the sample.

3.1.11.1 *Discussion*—The resultant radiation is then measured with an infrared detector and the resulting signal is decoded using a Fourier transform algorithm to compute the infrared spectrum.

3.1.12 *fuel cell grade hydrogen, n*—hydrogen satisfying the specifications in SAE TIR J2719.

3.1.13 *gaseous fuel, n*—hydrogen gas intended for use as a fuel cell feed gas or as a fuel for internal combustion engines.

3.1.14 *gauge pressure, n*—pressure measured above ambient atmospheric pressure; zero gauge pressure is equal to the ambient atmospheric (barometric) pressure (psig).

3.1.15 *path length, n*—the distance that the sample gas interacts with the infrared radiation.

3.1.16 *poisoning, v*—process by which catalysts are made inoperative due to the activity of substances such as hydrogen sulfide or other sulfur substances that can bind to a component in the catalyst (such as a noble metal like platinum) used in the fuel cell.

3.1.17 *proton exchange membrane fuel cells (PEMFCs), n*—PEMFC is an electrochemical apparatus that uses an anode and cathode to convert H<sub>2</sub> and O<sub>2</sub> into electricity.

3.1.18 *purified nitrogen (or purified N<sub>2</sub>), n*—nitrogen gas that is purified to Ultra-High Purity Grade (99.9995 %) or equivalent, containing total impurities <1 ppm, specifically: total hydrocarbons (THC) <0.1 ppm, total carbon dioxide + carbon monoxide (CO<sub>2</sub> + CO) <0.1 ppm, and water (H<sub>2</sub>O) <0.5 ppm.

3.1.19 *purified hydrogen (or purified H<sub>2</sub>), n*—hydrogen gas that is purified to Research Grade (99.9999 %) or equivalent, containing total impurities <1 ppm, specifically: total hydrocarbons (THC) <0.1 ppm, total carbon dioxide + carbon monoxide (CO<sub>2</sub> + CO) <0.1 ppm, and water (H<sub>2</sub>O) <0.5 ppm.

3.1.20 *qualitative accuracy, n*—the ability of an analytical system to correctly identify compounds without necessarily providing a precise concentration.

3.1.21 *quantitative accuracy, n*—the ability of an analytical system to measure the concentration of an identified compound.

3.1.22 *sample interface, n*—the entire sampling system consisting of the sample probe, sample transport line, and other components necessary to direct effluent to the FTIR gas cell.

3.1.23 *sampling system interference, n*—an interference that prohibits or prevents delivery of the target contaminants to the FTIR gas cell.

<sup>3</sup> Available from SAE International (SAE), 400 Commonwealth Dr., Warrendale, PA 15096-0001, <http://www.sae.org>.

<sup>4</sup> Available from United States Environmental Protection Agency (EPA), Ariel Rios Bldg., 1200 Pennsylvania Ave., NW, Washington, DC 20460, <http://www.epa.gov>.

3.1.23.1 *Discussion*—Examples of potential sampling system interferences are unwanted moisture condensation within the sampling system, heavy deposition of particulate matter or aerosols within the sampling system components, or reactive gases.

3.1.24 *static calibration, n*—calibration of an analytical system using standards in a matrix state or manner different than the samples to be analyzed.

3.1.25 *target contaminant (or target impurity or impurity), n*—a contaminant found in the gaseous fuel that may adversely affect or is required to be reported prior to use within the fuel cell system, hydrogen storage system, or engine used in combustion applications.

## 4. Summary of Test Method

4.1 *Test Plan Preparation*—The tester should prepare a test plan that includes a description of the fuel source, requirements for the sampling interface, list of target contaminant species to be measured, and measurement requirements for these contaminants.

4.2 *Calibration*—A set of calibration spectra is prepared for each hydrogen fuel contaminant to be measured. Typically spectra are collected at multiple concentration levels of a single contaminant spanning the expected concentration range for that contaminant within the gaseous sample. Certified gas standards or permeation tubes are used with a gas blending system as per 7.7 to prepare samples of known concentration of the target contaminant within a purified H<sub>2</sub> matrix gas and spectra are collected using the FTIR instrument. The impurity concentration, measurement path length, gas temperature, and absolute pressure for the calibration sample are stored together with each spectrum. These calibrations are generally permanent and transferable between FTIR instruments of similar type. Verification of calibrations can be performed before each test using a calibrated cylinder that contains one or more of the target species in a purified H<sub>2</sub> matrix gas, thus it is not necessary to recalibrate prior to each test.

4.2.1 *Calibration Using Surrogate Matrix Gas*—The use of a surrogate matrix gas such as nitrogen (N<sub>2</sub>) or helium (He) to create the known target contaminant (or impurity) concentration is not acceptable according to this method. The FTIR spectral line shape of the impurity within a matrix other than that of H<sub>2</sub> is sensitive to the differences between the matrix in N<sub>2</sub> or He, resulting in different line shapes for the same impurity concentrations. More detailed studies are needed to determine the effect of this line shape change on contaminant determination. Therefore, use of a surrogate gas is not acceptable unless the user has studied and determined conditions under which the measurement precision and accuracy of data satisfy the users needs and requirements.

4.3 *Evaluation of Detection Limits*—Detection limits are first estimated after the calibrations are created by measuring a blank which consists of a purified hydrogen gas sample that does not contain any of the target contaminants as listed in 3.1.19. Several of the blank samples are measured using the final analytic method that includes detection for all of the target contaminants and interferences, and then a preliminary detection limit estimate is made based upon the standard deviation of the

reported concentrations for each contaminant. Then, for all of the contaminants that are to be certified, a purified hydrogen sample is prepared with a blend of the target contaminants at concentrations near the initial estimated detection limits. Several measurements are performed on this blended matrix, as well as several purified hydrogen blanks and then a more accurate detection limit is calculated based upon the standard deviation of the reported concentrations of both the blanks and blended gas samples.

4.4 Field measurements of hydrogen fuel are performed using direct sampling from high pressure fuel nozzles or other high pressure storage containers provided the final gas pressure can be stepped down to 20 psig (139 kPa(g)) without altering the fuel composition for introduction into the FTIR flow cell. The fuel sampling apparatus and the FTIR measurement system are flushed with purified nitrogen or hydrogen and then a background reference spectrum is taken. After flushing the system and taking a background spectrum, a minimum of three samples of the purified nitrogen or hydrogen are measured to verify that impurities are not introduced by the sampling apparatus. Hydrogen fuel is introduced to the sampling apparatus and at least three different samples are measured to determine the impurity concentrations in the fuel. A new blank is run through the gas cell between each sample that is run to ensure that the system is at an equilibrium state.

4.5 Laboratory measurements of samples collected in the field can be performed in a similar manner to those taken in the field. Hydrogen fuel is introduced and then collected into three high pressure storage vessels as described in Practices D5287 and D7606. The samples are then transported to the laboratory, and then the storage vessel is connected to the laboratory sampling apparatus. The sampling apparatus is flushed a minimum of three times with purified nitrogen or hydrogen. Purified hydrogen is then introduced into the FTIR flow cell, and at least three samples are measured to verify that impurities are not introduced by the sampling apparatus. The hydrogen fuel from the high pressure storage vessel is then introduced to the sampling apparatus, and three samples are measured after all of the signals for each of the target contaminants have reached an equilibrium value. These samples are used to determine the contaminant concentrations in the sampled hydrogen fuel. This process is repeated for each of the high pressure storage vessels collected from the same fuel source. While the number listed in the section is for collecting three separate samples, that number will be designated by the final governing body overseeing the Hydrogen Fuel testing.

## 5. Significance and Use

5.1 Fuel cell users have implicated trace impurities in feed gases as compromising the performance and lifespan of proton exchange membrane fuel cells (PEMFCs). PEMFCs may be damaged by the presence of some contaminants through poisoning of fuel cell electrode materials; therefore detection of these impurities at low concentrations is critical to fuel cell manufacturers and feed gas suppliers in order to support the facilities and infrastructure required for widespread applicability of fuel cells in transportation and energy production. With field-portable equipment, this test method can be used to

quickly analyze hydrogen fuel for impurities at vehicle fueling stations or storage tanks used to supply stationary power plants. This test method can also be used by gas suppliers, customers, and regulatory agencies to certify hydrogen fuel quality.

5.2 Users include hydrogen producers, gaseous fuel custody transfer stakeholders, fueling stations, fuel cell manufacturers, automotive manufacturers, regulators, and stationary fuel cell power plant operators.

## 6. Interferences

6.1 *Spectral Interferences*—Spectral interference occurs when the spectrum of a target contaminant overlaps with the spectrum of another component in the sample. The effects of spectral interferences can often be minimized by using appropriate analytical algorithms or by adjusting spectral analysis regions to minimize spectral interference.

6.2 *Sampling System Interferences*—Sampling system interferences occur when target contaminants are retained by the sampling system plumbing or components resulting in reduced concentration of the target contaminants at the measurement system. Sampling system interferences can also occur if target contaminants outgas or desorb from the sampling system plumbing or components, resulting in increased concentrations at the measurement system. Care must be taken in the system design to minimize these affects.

## 7. Apparatus

7.1 Fourier Transform Infrared (FTIR) spectrometer with gas cell and detector having sufficient path length and sensitivity respectively to measure the target contaminants at or below the required detection limits. The entire optical path of the spectrometer should be sealed to allow either purging or evacuation to prevent interference from ambient water vapor and carbon dioxide in the spectrometer's optical path. The gas sampling cell should also be sealed to prevent leaking inside the spectrometer of the H<sub>2</sub> gas sample to the atmosphere.

7.2 The sample delivery lines to the gas sampling cell as well as out of the cell should be sealed to allow either purging or evacuation to prevent interference from ambient water vapor and carbon dioxide. The sample delivery lines or tubing should also be leak free and equilibrated with respect to air contaminants such as water and carbon dioxide.

7.3 Computer and software to control the FTIR spectrometer and to collect, process, and store FTIR spectra. It is also required for the software to both monitor the temperature and pressure of the sample in the gas cell while collecting spectra. It should also be able to automatically correct for differences in the pressure and temperature recorded for the calibration samples to those measured in the sample gas.

7.4 Hydrogen gas purifier to prepare Research Grade purified hydrogen gas (99.9999 %) from ultra high purity hydrogen (99.999 %) for zeroing the measurement instrument, mixing calibration standards, and testing the zero response of the system. Purifiers that can remove the impurities to less than 1 ppb levels are preferred.

7.5 Nitrogen gas purifier to prepare Ultra High Purity grade purified nitrogen gas (99.9995 %) from high purity nitrogen (99.999 %) for zeroing the measurement instrument and purging the FTIR optics.

7.6 *Tubing*, electropolished TFC 316 stainless steel or other inert material, of suitable diameter and length.

7.7 *Gas Blending Apparatus* (See Fig. 1), for diluting calibration gas standards with purified hydrogen in order to create standards of the target contaminant species at the desired concentrations for both creating calibrations and determining detection limits. The gas blending apparatus uses mass flow controllers suitable for the required flow rates with traceable calibrations and  $\pm 0.5$  % accuracy for the flow range to be employed. The mass flow controllers must also be calibrated for use with H<sub>2</sub> gas and recertified annually to assure continued suitable operation. The gas blending apparatus includes a temperature-controlled oven for permeation tubes which can be used to prepare gas standards of liquids or other reactive compounds. The output of the permeation tube oven is controlled by a second mass flow controller and a backpressure regulator to allow for a large range of flow rates through the permeation tube oven while maintaining a relatively constant (lower) flow through the FTIR gas cell.

7.8 *Apparatus for Measuring Samples Directly from High Pressure Nozzles* (See Fig. 2)—This apparatus is used to sample and analyze gaseous hydrogen fuel directly from high pressure fueling nozzles or similar interfaces used in fueling automotive vehicles and stationary appliances. This apparatus reduces the pressure of the fuel and provides an appropriate flow directly to the FTIR measurement system for analysis. The apparatus typically consists of a J2600 receptacle connected to a fueling station J2600 nozzle, an ultra high purity check valve, appropriate pressure regulator to reduce the pressure to approximately 20 psig (139 kPa(g)), and a metering valve or flow controller to set an appropriate flow rate through the FTIR gas cell. The apparatus also includes a means to introduce purified nitrogen or hydrogen gas as well as calibration gases into the gas sampling cell in order to verify the system zero or calibration integrity. High purity nitrogen is also used to purge the FTIR measurement system interferometer and optics.

7.9 *Apparatus for Measuring Samples from High Pressure Storage Containers* (See Fig. 3)—This apparatus is similar to the direct sampling apparatus except for the interface to the hydrogen fuel to be measured. Fuel samples are collected in high pressure storage vessels as described in Practices D5287 and D7606 using the methodology and apparatus described therein. The storage vessel is then connected to the apparatus shown in Fig. 3. When ready to measure, the hydrogen fuel sample is introduced by opening valve V4 and setting the pressure regulator to approximately 20 psig (139 kPa(g)). The needle valve is used to set the correct flow rate through the FTIR gas cell.

7.10 Ultra high purity (UHP) nitrogen is required for purging the FTIR spectrometer and optics assembly. Purge nitrogen gas should be 99.9995 % pure and have a dew point at or below  $-60$  °C. If a lower grade of nitrogen is used, then

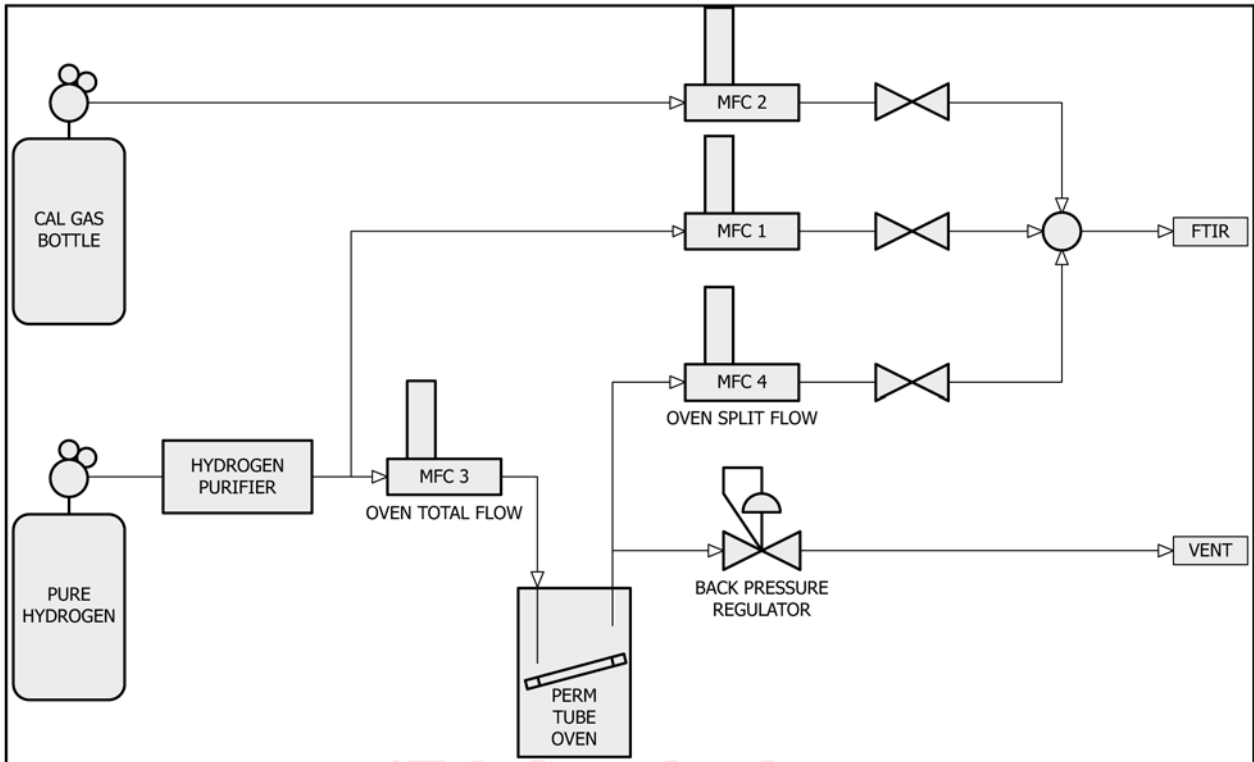

FIG. 1 Gas Blending Apparatus. Mass Flow Controller (MFC)

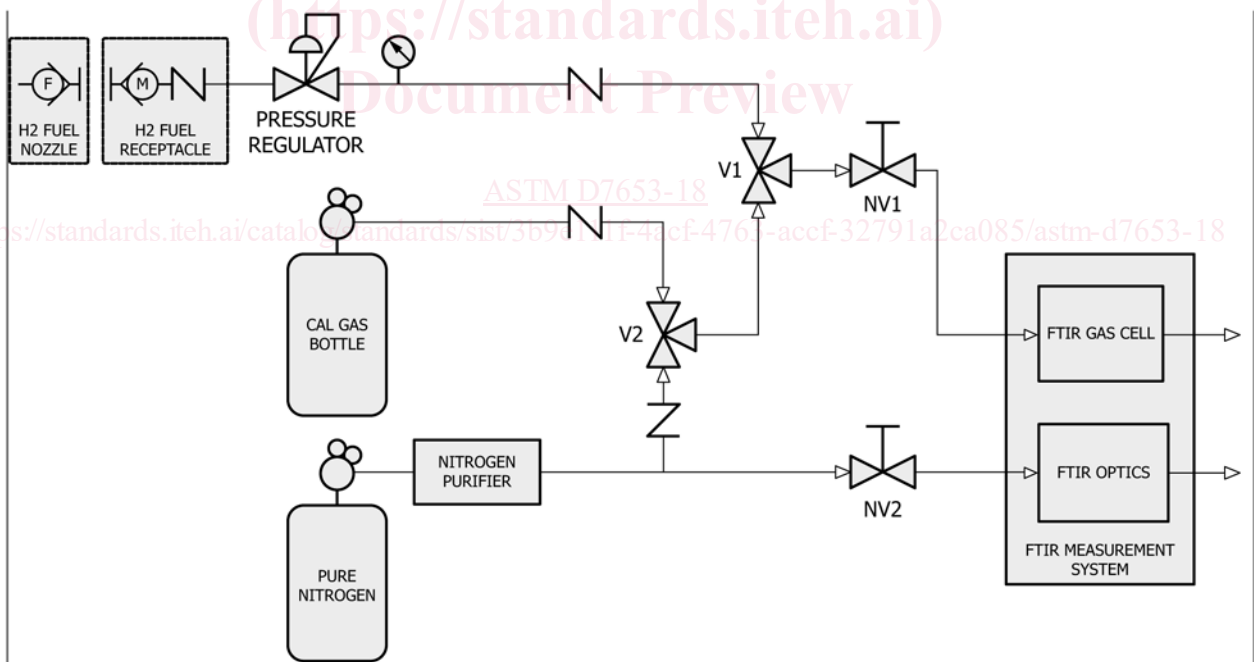

FIG. 2 Apparatus for Measuring Samples Directly from High Pressure Nozzles. Line Switching Valve (V), Needle Valve (NV)

a  $N_2$  purifier must be used to remove impurities such as total hydrocarbons, CO,  $CO_2$ , and  $H_2O$  to less than 1 ppm or better in order to achieve the UHP grade requirement. The use of the

purifier results in overall stability of the background of the instrument so it is recommended to be used even if UHP nitrogen is used.

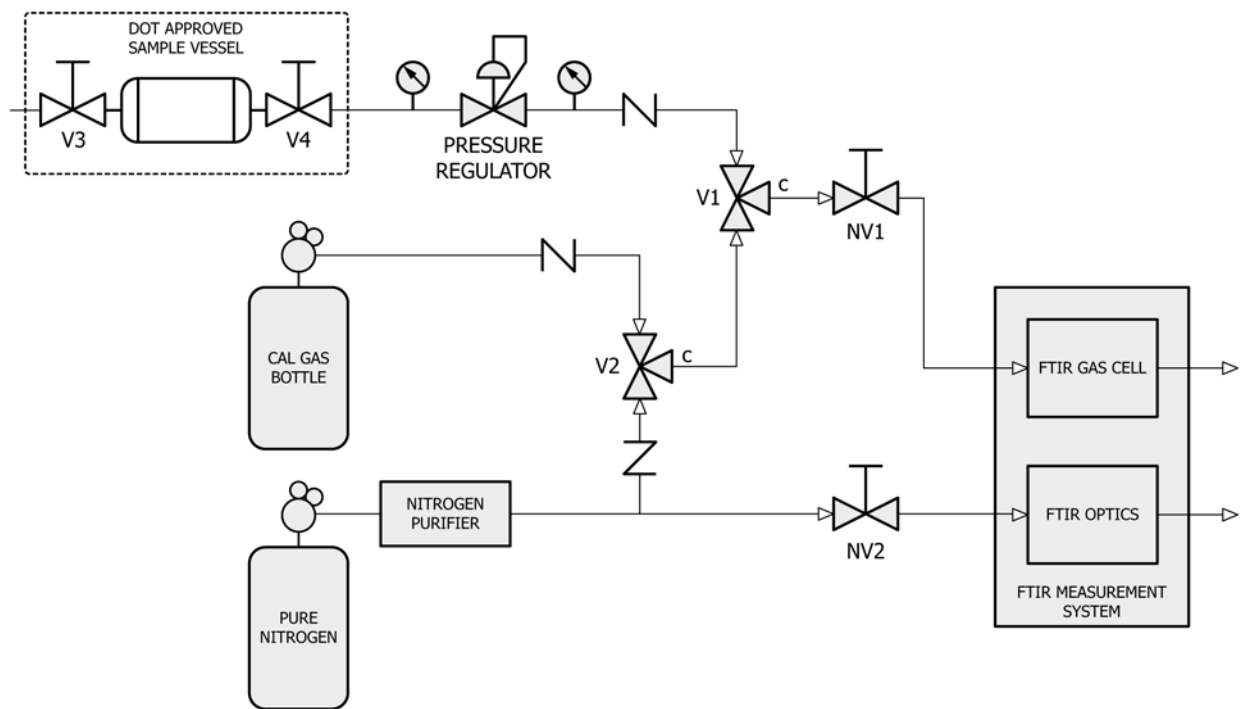

FIG. 3 Apparatus for Measuring Samples from High Pressure Storage Containers. Line Switching Valve (V), Needle Valve (NV)

7.11 Research Grade purified hydrogen gas (99.9999 % pure) is required for blending calibration samples and to perform baseline measurements (when possible). Purified hydrogen must be run through a H<sub>2</sub> purifier to remove moisture and other impurities such as total hydrocarbons, CO, and CO<sub>2</sub>, to less than 1 ppb each prior to use with the measurement system.

7.12 Calibration gas standards prepared in hydrogen for measurement of calibration spectra and for verification of sample system integrity. Gas standards should be provided with a National Institute of Standards and Technology (NIST) traceable certification at or below  $\pm 2\%$  accuracy. Multiple target contaminants may be mixed in a single calibration gas bottle provided that the mixed species are non-reactive, do not degrade in the presence of the other components, and must not interfere spectrally (in the FTIR regime) with any of the other target contaminants in the mixture.

7.13 Permeation tubes are used to prepare known concentrations of contaminants that are liquids or reactive compounds. Permeation tubes should be provided with a NIST traceable certification at or below  $\pm 2\%$  accuracy. A permeation oven that operates above ambient temperature is required to be used in order to achieve the accuracy of the permeation tube standards.

## 8. Hazards

8.1 Care should be taken to avoid hazards associated with both high and ambient pressure hydrogen leaks in the sampling apparatus or measurement system. Redundant safety measures such as hydrogen monitors and nitrogen purged enclosures around the instrument are recommended to ensure that poten-

tially combustible gas mixtures do not come in contact with any ignition sources (for example, infrared source, electronics, etc.).

8.2 Some of the gas mixtures used for calibration are potentially harmful or dangerous if not vented properly from the measurement system or sampling apparatus. Review the Material Safety Data Sheets (MSDS) for all materials and be sure to use proper safety precautions.

## 9. Calibration

### 9.1 Preparation:

9.1.1 *Concentration Range for Calibration Spectra*—Collect calibration spectra spanning the expected ranges in the fuel samples for each target contaminant as well as any other impurity that may be present in the hydrogen fuel sample which are active in the infrared region. The lowest concentration should be at or near the contaminant limit defined in the test plan. The upper concentration should be high enough to prevent the need to extrapolate to higher concentrations. Typically ten or more calibration points are collected for each contaminant (target impurity) species.

9.1.2 *FTIR Spectrometer Settings*—Collect calibration spectra with the FTIR gas cell at approximately the same temperature and pressure as will be used for measuring hydrogen fuel samples. Due to changes in the ambient field temperatures it is best to use elevated gas cell temperatures (>35 °C) to avoid fluctuations or temperature mismatch due to changes in the ambient temperature. Be sure to use the same FTIR spectral resolution and apodization function for calibrations and measurements. The gas cell path length is chosen to provide adequate sensitivity while maintaining maximum absorbance