



Designation: **F2421 – 19 F2421 – 19a**

## Standard Test Method for Measurement of Resilient Floor Plank by Dial GageGauge<sup>1</sup>

This standard is issued under the fixed designation F2421; the number immediately following the designation indicates the year of original adoption or, in the case of revision, the year of last revision. A number in parentheses indicates the year of last reappraisal. A superscript epsilon ( $\epsilon$ ) indicates an editorial change since the last revision or reappraisal.

### 1. Scope

1.1 This test method establishes the procedures for determination of both dimension (length and width) and squareness of a rectangular resilient floor plank. ~~This test method is intended for use with rectangular plank up to 36 in. (915 mm).~~

1.2 The values stated in inch-pound units are to be regarded as standard. The values given in parentheses are mathematical conversions to SI units that are provided for information only and are not considered standard.

1.3 *This standard does not purport to address all of the safety concerns, if any, associated with its use. It is the responsibility of the user of this standard to establish appropriate safety, health, and environmental practices and determine the applicability of regulatory limitations prior to use.* Specific precautionary statements are provided in applicable sections of this test method.

1.4 The values stated in inch-pounds units are to be regarded as the standard. The values given in parentheses are for information only.

1.5 *This international standard was developed in accordance with internationally recognized principles on standardization established in the Decision on Principles for the Development of International Standards, Guides and Recommendations issued by the World Trade Organization Technical Barriers to Trade (TBT) Committee.*

### 2. Referenced Documents

2.1 *ASTM Standards:*<sup>2</sup>

**F141 Terminology Relating to Resilient Floor Coverings**

2.2 *ANSI Standards:*<sup>3</sup>

**ANSI/ASQC Z1.4-1993Z1.4 Sampling Procedures and Tables for Inspection by Attributes**

### 3. Terminology

3.1 *Definitions:* For definitions of terms used in this test method, refer to Terminology **F141**.

3.2 *resilient floor plank*—shape of a modular flooring element where the length is generally significantly longer than the width, by at least 2/1, L/W (length/width) aspect ratio. Typical plank maximums for width run  $\leq 18$  in. (457.2 mm) and maximums for length  $\leq 8$  ft (2.44 m).

### 4. Significance and Use

4.1 The combination of both dimensional properties and squareness of resilient floor plank is an important consideration because installed flooring may exhibit an objectionable appearance when either or both characteristics deviate from established tolerances. This test method provides a means of determining length and width dimensions along with squareness, by using a single apparatus and procedure.

### 5. Apparatus

5.1 ~~The apparatus example shall consist~~ apparatus consists of five dial gagesgauges and two reference index strips mounted on a flat bedplate in a configuration that, by rotation and flipping of the sample, allows the measurement of all four sides of resilient plank samples. (See **Fig. 1**). One edge of the bedplate is elevated to create a test surface, which is offset or tilted  ~~$\pm 15^\circ$~~   $15 \pm 1$  degrees from horizontal. The offset applies minimal pressure to the test specimen against the longer index strip to ensure repeatable

<sup>1</sup> This test method is under jurisdiction of ASTM **F06** Committee on Resilient Floor Coverings and is the direct responsibility of subcommittee **F06.20** on Test Methods. Current edition approved Jan. 1, 2019Feb. 1, 2019. Published February 2019March 2019. Originally approved in 2005. Last previous edition approved in 20112019 as F2421-05 (2011)—19. DOI: 10.1520/F2421-19.10.1520/F2421-19A.

<sup>2</sup> For referenced ASTM standards, visit the ASTM website, [www.astm.org](http://www.astm.org), or contact ASTM Customer Service at [service@astm.org](mailto:service@astm.org). For *Annual Book of ASTM Standards* volume information, refer to the standard's Document Summary page on the ASTM website.

<sup>3</sup> Available from American National Standards Institute—Institute (ANSI), 25 West W. 43rd St., 4th Floor, New York, NY 10036-10036, <http://www.ansi.org>.

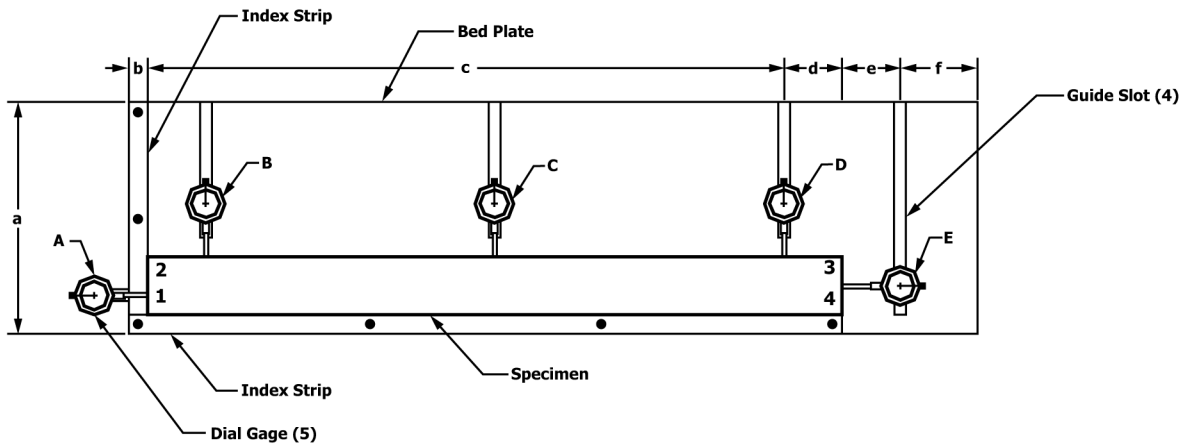

Dimensions				
in.		mm		
	Dimension	tolerance	Dimension	tolerance
a	12		305	
b	1		25	
c	33		838	
d	3		76	
e	3		76	
f	4		102	

FIG. 1 Example Plank Measurement Apparatus

measurement. A reference plate representing target plank size and squareness (see Fig. 2) is used to zero all dial gauges. Reference plate must be substantial and not readily subjected to deflection or distortion, i.e. 1/2 in. (12.7 mm) aluminum, ±0.001 in. (0.025 mm) tolerance for stated length and width and for squareness allowable tolerance shall be 90 degrees ± 10 s (1.57080 ± 0.0005 rad). Dial gauges should be mounted on adjustable height brackets to allow for optimizing measurement location, especially for planks with profiled edges (see Fig. 3) and 5.2.

5.2 Dial Gauges—Gauges—The five dial gauges are mounted in guide slots, which are machined into the bedplate to allow for measurement of various plank sizes. For the two corner gauges (B & D) and the squareness gage (A) the position must be at least within 10 % of the corner edge relative to the respective length and width of the plank. For the center gauges (C & E) the position must be at least within 10 % of the centerline relative to the respective length and width of the plank. Any dial gauges may report measurements using either electrical or mechanical means, but shall be graduated to read to the 0.001 in. (0.025 mm) and have a stem travel greater than 0.25 in. (6.4 mm). The contact foot of the dial-gage stem shall be flat, 0.50 to 0.75 in. ± 0.001 in. (12.7-19.1 (12.7 to 19.1 mm ± 0.025 mm) in diameter and exert a total force of not more than 3.0 ± 0.1ozf ± 0.1 ozf (0.83 ± 0.003 N). For planks with profiled edges, that are contacting the edge of the plank face, above the protruding profiled edge (see Fig. 3), the contact foot must be smaller because the area of measurement is smaller. A round flat foot, 1/8 in. (3.175 mm) to 3/16 in. (4.7625 mm) in size (see Fig. 4) with the same maximum force recommendations as above is recommended. Dial gauges shall be positioned securely so that when the reference plate is and specimen are in place, the contact foot is extended approximately 50 % of its full travel and contacts the plank edge at approximately the center of the measurement foot.

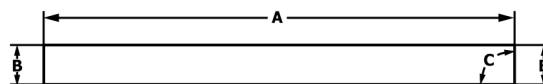

- A: Length Dimension +/- 0.001 in (0.025 mm)
- B: Width Dimension +/- 0.001 in (0.025 mm)
- C: 90 degrees +/- 10s (1.57080 +/- 0.0005) rad

FIG. 2 Example Reference Plate with Allowable Tolerance