

INTERNATIONAL STANDARD



Environmental testing – iTeh Standards
Part 3-7: Supporting documentation and guidance – Measurements in
temperature chambers for tests A (Cold) and B (Dry heat) (with load)

Document Preview

[IEC 60068-3-7:2020](https://standards.iteh.ai/catalog/standards/iec/a6a12324-a3da-4a15-b822-fdd788d87308/iec-60068-3-7-2020)

<https://standards.iteh.ai/catalog/standards/iec/a6a12324-a3da-4a15-b822-fdd788d87308/iec-60068-3-7-2020>





THIS PUBLICATION IS COPYRIGHT PROTECTED
Copyright © 2020 IEC, Geneva, Switzerland

All rights reserved. Unless otherwise specified, no part of this publication may be reproduced or utilized in any form or by any means, electronic or mechanical, including photocopying and microfilm, without permission in writing from either IEC or IEC's member National Committee in the country of the requester. If you have any questions about IEC copyright or have an enquiry about obtaining additional rights to this publication, please contact the address below or your local IEC member National Committee for further information.

IEC Central Office
3, rue de Varembe
CH-1211 Geneva 20
Switzerland

Tel.: +41 22 919 02 11
info@iec.ch
www.iec.ch

About the IEC

The International Electrotechnical Commission (IEC) is the leading global organization that prepares and publishes International Standards for all electrical, electronic and related technologies.

About IEC publications

The technical content of IEC publications is kept under constant review by the IEC. Please make sure that you have the latest edition, a corrigendum or an amendment might have been published.

IEC publications search - webstore.iec.ch/advsearchform

The advanced search enables to find IEC publications by a variety of criteria (reference number, text, technical committee,...). It also gives information on projects, replaced and withdrawn publications.

IEC Just Published - webstore.iec.ch/justpublished

Stay up to date on all new IEC publications. Just Published details all new publications released. Available online and once a month by email.

IEC Customer Service Centre - webstore.iec.ch/csc

If you wish to give us your feedback on this publication or need further assistance, please contact the Customer Service Centre: sales@iec.ch.

Electropedia - www.electropedia.org

The world's leading online dictionary on electrotechnology, containing more than 22 000 terminological entries in English and French, with equivalent terms in 16 additional languages. Also known as the International Electrotechnical Vocabulary (IEV) online.

IEC Glossary - std.iec.ch/glossary

67 000 electrotechnical terminology entries in English and French extracted from the Terms and Definitions clause of IEC publications issued since 2002. Some entries have been collected from earlier publications of IEC TC 37, 77, 86 and CISPR.

[IEC 60068-3-7:2020](https://standards.iteh.ai/catalog/standards/iec/a6a12324-a3da-4a15-b822-fdd788d87308/iec-60068-3-7-2020)

<https://standards.iteh.ai/catalog/standards/iec/a6a12324-a3da-4a15-b822-fdd788d87308/iec-60068-3-7-2020>



IEC 60068-3-7

Edition 2.0 2020-07
REDLINE VERSION

INTERNATIONAL STANDARD



Environmental testing – iTeh Standards
Part 3-7: Supporting documentation and guidance – Measurements in
temperature chambers for tests A (Cold) and B (Dry heat) (with load)

Document Preview

[IEC 60068-3-7:2020](https://standards.iteh.ai/catalog/standards/iec/a6a12324-a3da-4a15-b822-fdd788d87308/iec-60068-3-7-2020)

<https://standards.iteh.ai/catalog/standards/iec/a6a12324-a3da-4a15-b822-fdd788d87308/iec-60068-3-7-2020>

INTERNATIONAL
ELECTROTECHNICAL
COMMISSION

ICS 19.040; 29.020

ISBN 978-2-8322-8641-8

Warning! Make sure that you obtained this publication from an authorized distributor.

CONTENTS

FOREWORD.....	3
INTRODUCTION.....	2
1 Scope.....	6
2 Normative references	6
3 Terms and definitions	6
4 Measuring system	8
4.1 General description.....	8
4.2 Temperature	8
4.2.1 General	8
4.2.2 Temperature sensor	9
4.3 Humidity	9
4.3.1 General	9
4.3.2 Humidity sensor.....	9
4.4 Wall emissivity	9
4.5 Air velocity	9
4.5.1 General	9
4.5.2 Air velocity sensor	9
4.5.3 Air velocity sensor response time	9
4.6 Recording device	9
5 Determination of temperature performances	9
5.1 Test area environment	9
5.2 Chamber loading.....	10
5.2.1 General	10
5.2.2 Location of test load	10
5.3 Installation of temperature sensors	10
5.3.1 General	10
5.3.2 Position of temperature sensors	10
5.3.3 Position of load sensors.....	10
5.3.3 Position of wall sensors.....	10
6 Test procedures	11
6.1 Confirmation methods	11
6.1.1 General	11
6.1.2 Test without load	11
6.1.3 Test with load	11
6.2 Routine monitoring methods	11
7 Evaluation criteria.....	12
8 Information to be given in the performance report.....	12
Bibliography.....	13
Figure 1 – Examples of artificial loads.....	8
Figure 2 – Location of wall sensors.....	8
Table 1 – Test conditions.....	7
Table 2 – Artificial load – Values.....	8

INTERNATIONAL ELECTROTECHNICAL COMMISSION

ENVIRONMENTAL TESTING –

**Part 3-7: Supporting documentation and guidance –
Measurements in temperature chambers for
tests A (Cold) and B (Dry heat) (with load)**

FOREWORD

- 1) The International Electrotechnical Commission (IEC) is a worldwide organization for standardization comprising all national electrotechnical committees (IEC National Committees). The object of IEC is to promote international co-operation on all questions concerning standardization in the electrical and electronic fields. To this end and in addition to other activities, IEC publishes International Standards, Technical Specifications, Technical Reports, Publicly Available Specifications (PAS) and Guides (hereafter referred to as “IEC Publication(s)”). Their preparation is entrusted to technical committees; any IEC National Committee interested in the subject dealt with may participate in this preparatory work. International, governmental and non-governmental organizations liaising with the IEC also participate in this preparation. IEC collaborates closely with the International Organization for Standardization (ISO) in accordance with conditions determined by agreement between the two organizations.
- 2) The formal decisions or agreements of IEC on technical matters express, as nearly as possible, an international consensus of opinion on the relevant subjects since each technical committee has representation from all interested IEC National Committees.
- 3) IEC Publications have the form of recommendations for international use and are accepted by IEC National Committees in that sense. While all reasonable efforts are made to ensure that the technical content of IEC Publications is accurate, IEC cannot be held responsible for the way in which they are used or for any misinterpretation by any end user.
- 4) In order to promote international uniformity, IEC National Committees undertake to apply IEC Publications transparently to the maximum extent possible in their national and regional publications. Any divergence between any IEC Publication and the corresponding national or regional publication shall be clearly indicated in the latter.
- 5) IEC itself does not provide any attestation of conformity. Independent certification bodies provide conformity assessment services and, in some areas, access to IEC marks of conformity. IEC is not responsible for any services carried out by independent certification bodies.
- 6) All users should ensure that they have the latest edition of this publication.
- 7) No liability shall attach to IEC or its directors, employees, servants or agents including individual experts and members of its technical committees and IEC National Committees for any personal injury, property damage or other damage of any nature whatsoever, whether direct or indirect, or for costs (including legal fees) and expenses arising out of the publication, use of, or reliance upon, this IEC Publication or any other IEC Publications.
- 8) Attention is drawn to the Normative references cited in this publication. Use of the referenced publications is indispensable for the correct application of this publication.
- 9) Attention is drawn to the possibility that some of the elements of this IEC Publication may be the subject of patent rights. IEC shall not be held responsible for identifying any or all such patent rights.

This redline version of the official IEC Standard allows the user to identify the changes made to the previous edition. A vertical bar appears in the margin wherever a change has been made. Additions are in green text, deletions are in strikethrough red text.

International Standard IEC 60068-3-7 has been prepared by IEC technical committee TC 104: Environmental conditions, classification and methods of test.

This second edition cancels and replaces the first edition published in 2001. This edition constitutes a technical revision.

This edition includes the following significant technical changes with respect to the previous edition:

- a) verbal forms have, in many parts, been changed to express requirements instead of recommendations ('shall' instead of 'should');
- b) Table 1 has been updated.

The text of this International Standard is based on the following documents:

FDIS	Report on voting
104/868/FDIS	104/873/RVD

Full information on the voting for the approval of this International Standard can be found in the report on voting indicated in the above table.

This document has been drafted in accordance with the ISO/IEC Directives, Part 2.

A list of all parts in the IEC 60068 series, published under the general title *Environmental testing*, can be found on the IEC website.

The committee has decided that the contents of this document will remain unchanged until the stability date indicated on the IEC website under "<http://webstore.iec.ch>" in the data related to the specific document. At this date, the document will be

- reconfirmed,
- withdrawn,
- replaced by a revised edition, or
- amended.

IMPORTANT – The 'colour inside' logo on the cover page of this publication indicates that it contains colours which are considered to be useful for the correct understanding of its contents. Users should therefore print this document using a colour printer.

INTRODUCTION

IEC 60068 (all parts) contains fundamental information on environmental testing procedures and severities.

The expression "environmental conditioning" or "environmental testing" covers the natural and artificial environments to which components or equipment may be exposed so that an assessment can be made of their performance under conditions of use, transport and storage to which they may be exposed in practice.

Temperature chambers used for "environmental conditioning" or "environmental testing" are not described in any publication, although the method of maintaining and measuring temperature and/or humidity has great influence on test results. The physical characteristics of temperature chambers can also influence test results.

iTeh Standards
(<https://standards.iteh.ai>)
Document Preview

[IEC 60068-3-7:2020](https://standards.iteh.ai/catalog/standards/iec/a6a12324-a3da-4a15-b822-fdd788d87308/iec-60068-3-7-2020)

<https://standards.iteh.ai/catalog/standards/iec/a6a12324-a3da-4a15-b822-fdd788d87308/iec-60068-3-7-2020>

ENVIRONMENTAL TESTING –

Part 3-7: Supporting documentation and guidance – Measurements in temperature chambers for tests A (Cold) and B (Dry heat) (with load)

1 Scope

This part of IEC 60068 ~~provides~~ specifies a uniform and reproducible method of confirming that temperature test chambers conform to the requirements specified in the climatic test procedures of IEC 60068-2-1 and IEC 60068-2-2, when loaded with either heat-dissipating or non heat-dissipating specimens under conditions which take into account air circulation inside the working space of the chamber. This document is ~~destined~~ intended primarily for users when conducting regular chamber performance monitoring.

2 Normative references

The following documents are referred to in the text in such a way that some or all of their content constitutes requirements of this document. For dated references, only the edition cited applies. For undated references, the latest edition of the referenced document (including any amendments) applies.

~~IEC 60068-2-1, Environmental testing – Part 2: Tests – Test A: Cold~~

~~IEC 60068-2-2, Basic environmental testing procedures – Part 2: Tests. Test B: Dry heat~~

~~IEC 60068-3-1, Basic environmental testing procedures – Part 3: Background information – Section one: Cold and dry heat tests~~

IEC 60068-3-5:2018, Environmental testing – Part 3-5: Supporting documentation and guidance – Confirmation of the performance of temperature chambers

~~IEC 60068-3-6, Environmental testing – Part 3-6: Supporting documentation and guidance – Confirmation of the performance of temperature/humidity chambers~~

~~IEC 60584-1, Thermocouples – Part 1: Reference tables~~

~~IEC 60751, Industrial platinum resistance thermometer sensors~~

3 Terms and definitions

For the purposes of this document, the following terms and definitions apply.

ISO and IEC maintain terminological databases for use in standardization at the following addresses:

- IEC Electropedia: available at <http://www.electropedia.org/>
- ISO Online browsing platform: available at <http://www.iso.org/obp>

3.1 test specification

procedure applied to test chambers with or without forced air circulation, suitable for a wide range of chamber sizes

Note 1 to entry: A summary of test conditions in IEC 60068-2-1 and IEC 60068-2-2 is given in Table 1; conditions including sudden change of temperature have been removed from earlier versions of these documents.

Table 1 – Test conditions

Temperature range	Test	Heat-dissipating		Change of temperature	
		None	With	Sudden	Gradual
-65 °C to +5 °C	Aa	⊖		⊖	
	Ab	⊖			⊖
	Ad		⊖		⊖
+30 °C to +400 °C	Ba	⊖		⊖	
	Bb	⊖			⊖
	Be		⊖	⊖	
	Bd		⊖		⊖

Temperature range	Test	Specimen heat-dissipation		Specimen power status		Change of temperature	Preferred air velocity	
		None	With	After stabilization	Throughout test	Gradual	High	Low
-65 °C to +5 °C	Ab	○				○	○	
	Ad		○	○		○		○
	Ae		○		○	○		○
+30 °C to +1 000 °C	Bb	○				○	○	
	Bd		○	○		○		○
	Be		○		○	○		○

3.2 confirmation method ~~(procedure 1)~~

specified method of making continuous measurements in order to establish whether the performance of a test chamber conforms to the requirements detailed in IEC 60068-2-1, test A and/or IEC 60068-2-2, test B

3.3 routine monitoring method ~~(procedure 2)~~

specified method of making measurements, continuously or at intervals, to ensure that the test chamber performance is being maintained

3.4 test load

test specimen that is installed in the test chamber for the confirmation measurements

Note 1 to entry: The test load is defined by geometric dimensions and by thermal properties.

3.5 artificial load

test load made in accordance with IEC 60068-3-7 with dimensions and thermal properties related to the geometric dimensions and thermal capacity of the specimens intended to be tested in the chamber

Note 1 to entry: Table 2 provides values for an artificial load and an example is given in Figure 1.

Table 2 – Artificial load – Values

Dimensions	Volume approximately 20 % of working space
Heat transmission	Approximately 10 kJ/m ² K
Heat radiation emissivity	> 0,7
Heat dissipation	In accordance with appendix C of IEC 60068-2-2:2007, 4.1.

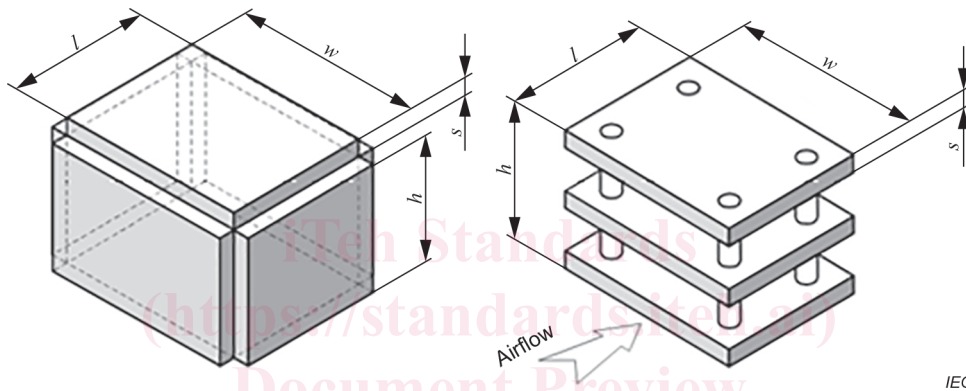

Key

- h* height
- l* length
- w* width
- s* thickness of material

NOTE *s* = 3 mm stainless steel or 4 mm aluminium (*h*, *l* and *w* should be smaller than the relevant dimensions of the working space).

Figure 1 – Examples of artificial loads

4 Measuring system

4.1 General description

The system used for the confirmation and routine monitoring measurements, either built-in or independent of the chamber, should comply with the following requirements. Measurement devices other than those listed may be used when their performance is shown to be technically equivalent or when practical concerns require alternative techniques. Deviations from these requirements shall be documented.

4.2 Temperature

4.2.1 General

Platinum resistance thermometers (in accordance with IEC 60751) or thermocouples (in accordance with IEC 60584-1) should be used.

4.2.2 Temperature sensor

In a temperature range from -200 °C to ~~$+200$~~ $+650\text{ °C}$ the sensor measurement uncertainty should be in accordance with class A of IEC 60751.

4.3 Humidity

4.3.1 General

The humidity test is required for confirmation of IEC 60068-2-2 tests only.

Place the independent humidity sensor as near as practical to the centre of the working space.

Types of humidity monitoring sensors are described in 4.34 of IEC 60068-3-6:2018.

4.3.2 Humidity sensor

Sensor measurement uncertainty should not exceed $\pm 3\%$ RH.

4.4 Wall emissivity

Emissivity of the chamber enclosure should be in accordance with ~~table IV of appendix J of~~ IEC 60068-3-1.

4.5 Air velocity

4.5.1 General

An airflow sensor should be installed such that the maximum air velocity impinging on the load can be monitored.

4.5.2 Air velocity sensor

The air velocity sensor measurement uncertainty should be compatible with IEC 60068-2-1 and 60068-2-2 tolerances.

4.5.3 Air velocity sensor response time

The air velocity sensor response time should be greater than 5 s to avoid any influence on it by airflow fluctuation.

4.6 Recording device

For confirmation monitoring, data should be recorded at least once per minute. For routine monitoring, data should be recorded at least once every 5 min. For the purpose of chamber verification, the device utilized for recording data ~~from the chamber monitoring sensors~~ should be independent of the chamber control system.

5 Determination of temperature performances

5.1 Test area environment

The environment in the test area shall be in accordance with 4.1 of IEC 60068-3-5:2018.

5.2 Chamber loading

5.2.1 General

Provision is made for measurement of test chamber performance with different loading conditions.

Test loads:	heat-dissipating non heat-dissipating
Artificial loads:	heat-dissipating non heat-dissipating

NOTE However, when testing large, high heat dissipating specimens, it ~~may~~ can be desirable to allow the specimen to develop thermal gradients by using 'free air' chambers or those with a low airflow (typically less than ~~4~~ 0,5 m/s). In such cases it is possible that the chamber ~~may~~ will not have a uniform temperature within the working space and it is ~~necessary~~ important to monitor the temperatures of the air entering and exiting the specimen.

5.2.2 Location of test load

The test load ~~should always~~ shall be located in the enclosure so that it is entirely within the working space.

~~For heat dissipating multiple loads, heating effects should be minimized in accordance with the following subclauses of IEC 60068-2-2:~~

~~no forced air circulation — 29.1.1.2 and 40.1.1.2,~~

~~forced air circulation — 29.1.2.2 and 40.1.2.2.~~

When testing multiple heat dissipating specimens, any heating effects between specimens and on the overall chamber temperature gradient shall be minimized.

5.3 Installation of temperature sensors

5.3.1 General

The temperature sensors ~~should~~ shall be protected from heating and cooling sources and from direct heat radiation. In addition, the wall and load sensors ~~should~~ shall be protected from convection heat transfer from the surrounding air by suitable insulation.

5.3.2 Position of temperature sensors

Position of temperature sensors shall be in accordance with 4.4 of IEC 60068-3-5:2018.

~~5.3.2 Position of wall sensors~~

~~When chamber walls are directly heated and/or cooled, additional sensors located in accordance with figure 2 are necessary.~~