



Designation: **C704/C704M – 15** **C704/C704M – 15^{ε1}**

Standard Test Method for Abrasion Resistance of Refractory Materials at Room Temperature¹

This standard is issued under the fixed designation C704/C704M; the number immediately following the designation indicates the year of original adoption or, in the case of revision, the year of last revision. A number in parentheses indicates the year of last reappraisal. A superscript epsilon (ϵ) indicates an editorial change since the last revision or reappraisal.

^{ε1} NOTE—Footnotes 3 and 4 were updated editorially in March 2019.

1. Scope

1.1 This test method covers the determination of relative abrasion resistance of refractory brick at room temperature. This test method can also be applied to castable refractories (see Metric Dimensions, Practice C861 and Practice C865) and plastic refractories (see Practice C1054).

1.2 *Units*—When values are stated in both SI and inch-pound units, the units are to be regarded separately as standard. The values stated in each system may not be exact equivalents; therefore, use each system independently of the other. Combining values from the two systems may result in ~~non-conformance~~ nonconformance with the standard. Several values are stated only in SI units as a matter of convention and to permit comparison of results. Included are the abrading media weight (grams), specimen weight (grams), specimen weight loss due to abrasion (grams), and the resultant volume loss (cubic centimeters).

1.3 *This standard does not purport to address all of the safety concerns, if any, associated with its use. It is the responsibility of the user of this standard to establish appropriate safety, health, and ~~health~~environmental practices and determine the applicability of regulatory limitations prior to use.*

1.4 *This international standard was developed in accordance with internationally recognized principles on standardization established in the Decision on Principles for the Development of International Standards, Guides and Recommendations issued by the World Trade Organization Technical Barriers to Trade (TBT) Committee.*

2. Referenced Documents

2.1 ASTM Standards:²

A681 Specification for Tool Steels Alloy

C134 Test Methods for Size, Dimensional Measurements, and Bulk Density of Refractory Brick and Insulating Firebrick

C179 Test Method for Drying and Firing Linear Change of Refractory Plastic and Ramming Mix Specimens ~~1-c704m-15e1~~

C861 Practice for Determining Metric Dimensions of Standard Series Refractory Brick and Shapes

C862 Practice for Preparing Refractory Concrete Specimens by Casting

C865 Practice for Firing Refractory Concrete Specimens

C1036 Specification for Flat Glass

C1054 Practice for Pressing and Drying Refractory Plastic and Ramming Mix Specimens

D4285 Test Method for Indicating Oil or Water in Compressed Air

E177 Practice for Use of the Terms Precision and Bias in ASTM Test Methods

E691 Practice for Conducting an Interlaboratory Study to Determine the Precision of a Test Method

2.2 American Society of Mechanical Engineers (ASME) Standard:³

B40.100 Pressure Gauges and Gauge Attachments

2.3 ASTM Adjuncts:⁴

Abrasion Tester (1 dwg)

¹ This test method is under the jurisdiction of ASTM Committee C08 on Refractories and is the direct responsibility of Subcommittee C08.03 on Physical Properties. Current edition approved March 1, 2015. Published April 2015. Originally approved in 1972. Last previous edition approved in 2014 as C704/C704M – 14. DOI: 10.1520/C0704_C0704M-15.10.1520/C0704_C0704M-15E01.

² For referenced ASTM standards, visit the ASTM website, www.astm.org, or contact ASTM Customer Service at service@astm.org. For *Annual Book of ASTM Standards* volume information, refer to the standard's Document Summary page on the ASTM website.

³ Available from American Society of Mechanical Engineers (ASME), ASME International Headquarters, Two Park Ave., New York, NY 10016-5990, <http://www.asme.org>.

⁴ Detailed prints for the construction of the test chamber are available ~~at a nominal cost~~ from ASTM International Headquarters. Order Adjunct No. [ADJC0704ADJC070419-E-PDF](http://www.astm.org). Adjunct digitized in 2019. An acceptable test chamber can be made from a weatherproof electrical switch box.

3. Summary of Test Method

3.1 This test method measures the volume of material in cubic centimeters abraded from a flat surface at a right angle to a nozzle through which 1000 g of size-graded silicon carbide grain is blasted by air at a prescribed air pressure.

4. Significance and Use

4.1 This test method measures the relative abrasion resistance of various refractory samples under standard conditions at room temperature.

4.2 The abrasion resistance of a refractory material provides an indication of its suitability for service in abrasive environments.

4.3 The results obtained by this test method could be different than those obtained in service because of the different conditions encountered.

5. Interferences (Factors known to Affect Results)

5.1 During development, a ruggedness test was performed using 114 by 114 by 12.7 mm [4½ by 4½ by ½ in.] float glass plates conforming to Specification C1036. Several factors were found to cause statistically significant effects on measured results (see Section 10).

5.1.1 *Nozzle Tube Inside Diameter*—Variation in the inside diameter of the flint glass nozzle tube statistically affected the abrasion values obtained on the glass plate. Ideal glass tube inside diameter is 4.8 mm. Glass tube lots purchased as 7 mm outside diameter tube with a nominal 1.1 mm wall thickness can have inside diameters ranging from 4.6 mm to 5.0 mm. For the ruggedness test, flint glass tube inside diameters of 4.7 mm and 4.9 mm were used. Take the statistically significant effect of this small tube inside diameter variation into consideration. Individually measure and choose all nozzle tubes to conform to a specified 4.8 mm inside diameter.

5.1.2 *Air Pressure*—Variation in the test air pressure statistically affected the abrasion values obtained on the glass plate. Air pressure as specified in this test method is 448 kPa [65 psi] measured by a gauge capable to $\pm 6.9 \text{ kPa}$ [$\pm 1 \pm 6.9 \text{ kPa}$ [$\pm 1 \text{ psi}$]]. For the ruggedness test, air pressure was maintained at values of 441 kPa [64 psi] and 455 kPa [66 psi] by the use of a calibrated master series pressure gauge. Take the statistically significant effect of this small air pressure variation into consideration and use only gauges as specified in 6.1.5. It is also recommended that air gauges be recalibrated at frequent intervals.

5.2 Factors that were found to be rugged during the test method evaluation were: (1) particle size variation of the silicon carbide grain between sizings of grain composed of 25% 20 mesh by 30 mesh and 75% 30 mesh by 50 mesh silicon carbide to one composed of 15% 20 mesh by 30 mesh and 85% 30 mesh by 50 mesh silicon carbide sizing, (2) nozzle to sample distance varying between 200 mm [7 7/8 in.] to 206 mm [8 1/8 in.], (3) silicon carbide grit amount between 995 g and 1005 g, and (4) test operator.

6. Apparatus

6.1 *Abrasion Tester*, used for measuring the abrasion resistance of refractory specimens, consisting of the following (Fig. 1 and Fig. 2):

6.1.1 *Blast Gun (Leitch Carco Gun Model LC-CG)⁵*, modified for this equipment as shown in Fig. 3. Other sand blast gun models or types may affect test results.

6.1.2 *Nozzle*—Make the nozzle from a piece of flint-glass tubing, 115 mm [4 ½ in.] long, 7 mm [0.276 in.] \pm 0.12 mm [0.005 in.] outside diameter, with a 1.1 mm [0.043 in.] \pm 0.03 mm [0.001 in.] wall thickness. When the Carco Blast Gun is used, this will replace the steel nozzle supplied with the gun. Cleanly cut the ends of the glass tube and do not fire polish them. Check the length and diameter of each tube prior to use. The diameter may be checked by the use of a gage consisting of a tapered stainless steel rod with the 4.8 mm (3/16 in.) diameter marked on the rod. The glass tubing is held in place by a 70 mm (2¾ in.) long piece of stainless steel or copper tubing with an inside diameter of 7.15 to 7.75 mm [9/32 to 5/8 in.] and an outside diameter of 9.53 mm [3/8 in.]. Flare the tubing at one end to sit snugly inside a 9.53 mm [3/8 in.] tubing nut. This sleeve is glued or soldered in place inside the 9.53 mm [3/8 in.] tubing nut, and is used primarily to hold the glass tubing perpendicular to the test sample, ensuring a proper vacuum within the gun. The end of the glass tube through which the abrading media enters the nozzle in the venturi chamber is inserted into a 15.9 mm [5/8 in.] outside diameter, 6.4 mm [¼ in.] inside diameter rubber grommet with a thickness of 4.75 to 6.4 mm [3/16 to ¼ in.]. The glass tube is placed through the sleeve in the tubing nut, compressing the grommet within the nut. The nut is attached to the gun. Fit the nozzle tightly into the grommet in order to achieve adequate vacuum (see 8.6). The glass tube is then positioned at a distance of 2 mm [0.08 in.] from the air-generator nozzle. This is done by using a brass rod, 4.5 mm [0.175 in.] in diameter with a shoulder 7.9 mm [5/16 in.] in diameter, 117 mm [4.59 in.] from the tip and inserting this rod into the glass tube. This will allow the operator to push the glass tubing up until the rod touches the venturi, ensuring a 2 mm [0.08 in.] gap between the venturi and the glass tubing.

⁵ The sole source of supply of the apparatus known to the committee at this time is Leitch & Company, 106 Abram Court, San Leandro, CA 64577. If you are aware of alternative suppliers, please provide this information to ASTM International Headquarters. Your comments will receive careful consideration at a meeting of the responsible technical committee,¹ which you may attend.

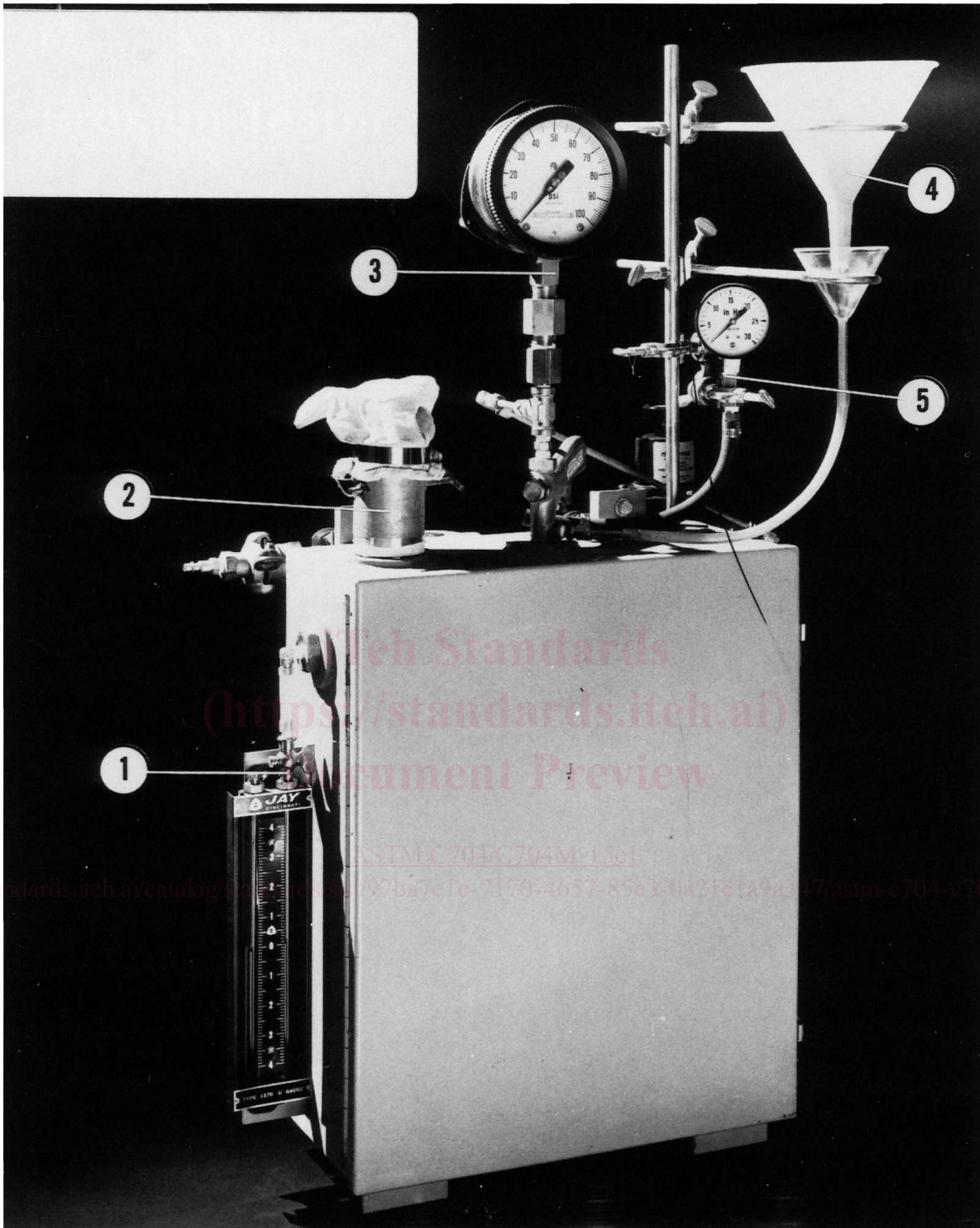

NOTE—Identified by number in this figure are: (1) cabinet pressure manometer, (2) dust collector vent, (3) test pressure gage, (4) grit feed tunnel, and (5) vacuum gage.

FIG. 1 Abrasion Tester

6.1.3 *Venturi*—The air generator nozzle dimensions are an inlet inside diameter of 2.84 to 2.92 mm [0.112 to 0.115 in.] and an outlet inside diameter of 2.36 to 2.44 mm [0.093 to 0.096 in.]. Inspect the air generator nozzle for wear before any test series and replace as necessary. The maximum inside diameter of the venturi chamber is 10 mm [$\frac{3}{8}$ in.]. Check the inside diameter periodically for wear (Fig. 4).

6.1.4 *Air Supply*—Supply the abrasion gun with clean dry air in accordance with Test Method D4285. The use of appropriate drying equipment is necessary in order to achieve consistent results. Ensure that the air supply is able to supply an adequate volume of air such that the air pressure does not fluctuate during the test run. If the air supply is also connected to other equipment, ensure

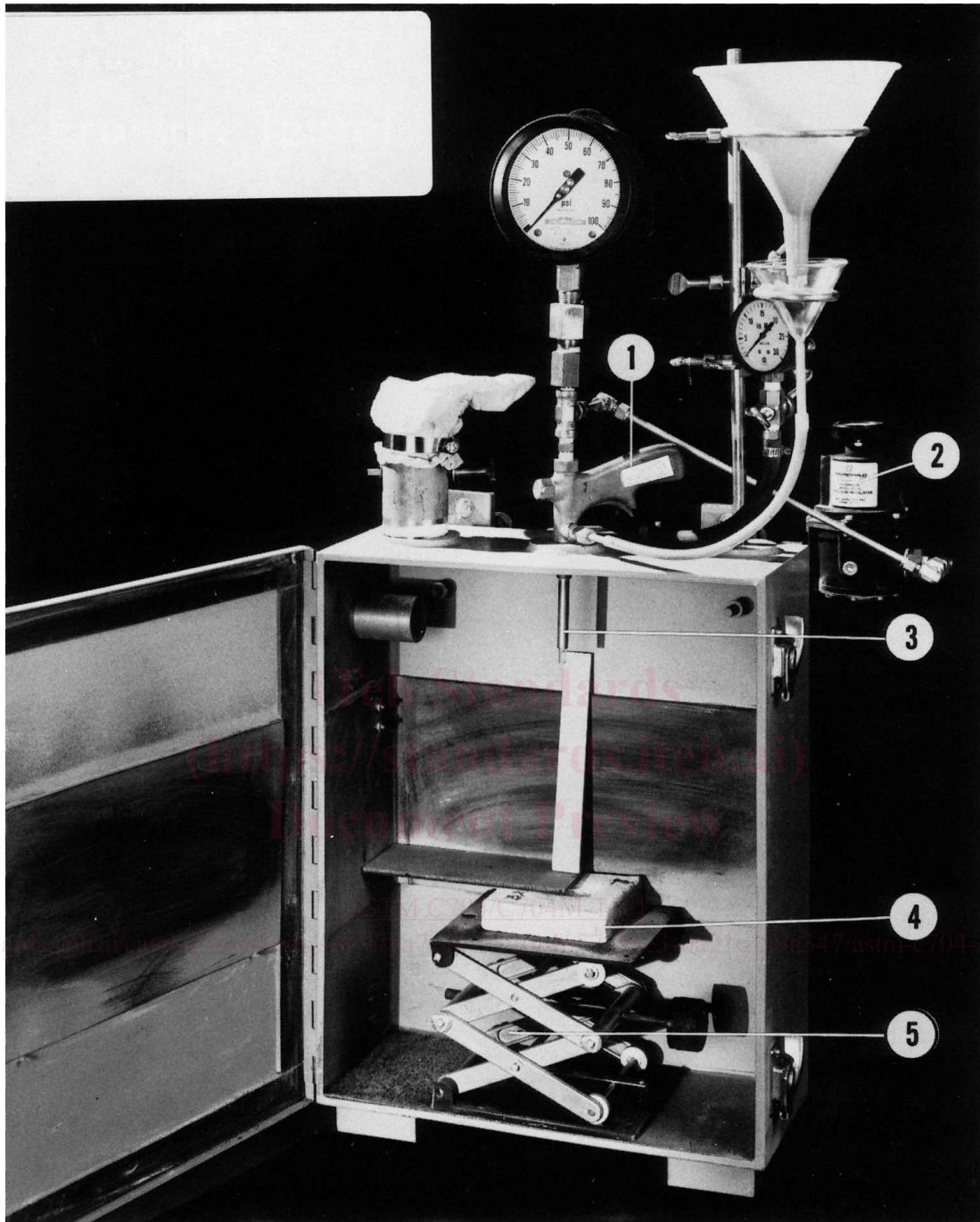

NOTE—Identified by number in this figure are: (1) sand blast gun, (2) air pressure regulator, (3) glass tube and metal stabilizing sleeve, (4) test sample, and (5) adjustable platform.

FIG. 2 Abrasion Tester

that the air supply is able to maintain consistent pressure throughout the test run, even when other equipment connected to the supply is operated. Consultation with an industrial professional in compressed air systems is recommended in setting up the air supply for the abrasion tester.

6.1.5 *Air Supply Pressure Gauge*—Affix a dial or digital test pressure gauge meeting the requirements of ASME B40.100, accuracy grade 3A, $\pm 0.25\% \pm 0.25\%$ of the span, to a fitting on top of the gun as shown on Fig. 1. Recommended span is 0 to 1000 kPa [0 to 100 psig] based on an anticipated air supply pressure of 455 kPa [65 psig].

6.1.6 *Abrading Media*—New (unused), sharp (angular, jagged edged grains), No. 36 grit silicon carbide containing minimal foreign material and having a screen analysis as shown in Table 1. Verify the sizing of the grit by either user confirmation of the

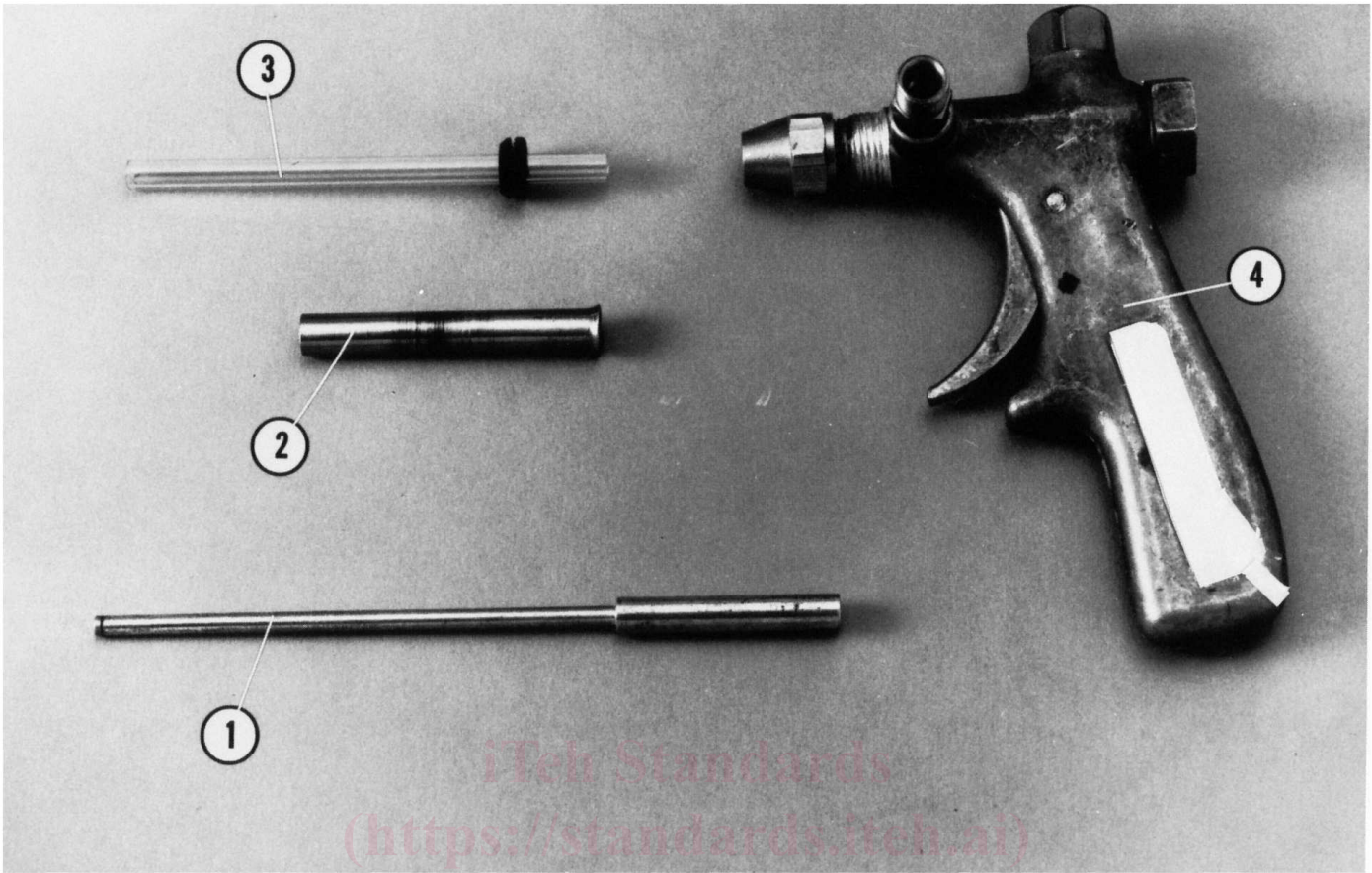

NOTE—Identified by number in this figure are: (1) glass tube adjustment rod, (2) metal stabilizing sleeve, (3) glass tube with grommet, and (4) sand blast gun.

FIG. 3—Modified Modified Blast Gun Breakdown

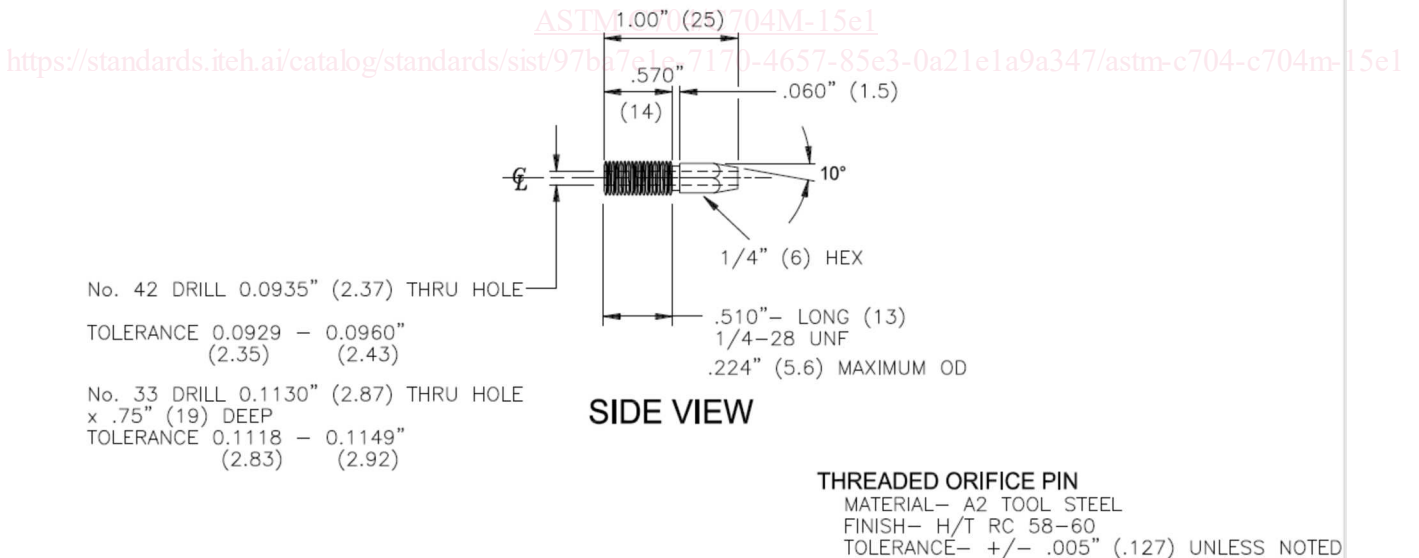

FIG. 4 Venturi Nozzle

screen analysis or a certificate of conformance from the supplier. Take care to avoid segregation in large containers of abrading media. Splitting (possibly with use of a riffler) or another similar procedure and reblending may be necessary to obtain a grit sample conforming to the required screen analysis.

6.1.7 *Feeding Mechanism*—Two acceptable mechanisms for feeding the abrading media are shown in Fig. 5. The feed funnel contains a suitable orifice to obtain a flow time of 450 ± 15 s while delivering 1000 g of abrading media into the gun supply funnel.

TABLE 1 Screen Analysis for Abrading Media

ASTM Standard Sieve No.	Opening, μm	Retained, %
20	850	trace
30	600	20 \pm 2
50	300	80 \pm 3
70	212	2 max
Pass No. 70	...	trace

Metal, glass, or plastic orifices may be used to regulate the flow. Provide an air gap between the orifice and the gun supply funnel to allow secondary air to enter with the abrading media.

6.1.8 *Test Chamber*—A tightly sealed closure with a door to permit ready access for mounting and removing the test specimens. Cut a 13-mm [$\frac{1}{2}$ in.] mounting hole in the top of the test chamber to permit the vertical mounting of the blast gun such that the downward stream of abrading media will travel 203 mm [8 in.] from the glass nozzle tip to the test specimen. Equip the test chamber with a 52 mm [$2\frac{1}{16}$ in.] exhaust with a butterfly valve to regulate the cabinet pressure. Fig. 1 and Fig. 2 show the design of an acceptable chamber.⁴

6.1.8.1 *Dust Collector*—A dust-collecting cloth or paper bag of adequate capacity may be used on the exhaust port of the chamber. Alternate dust handling systems such as venting to the outside are acceptable as long as the chamber pressure is maintained at the desired level.

6.1.8.2 *Chamber Pressure Manometer*—Water manometer, digital manometer, or magnehelic gauge with a span of 0 to 80 mm (0 to 3 in.) water based on an operating pressure of 32 mm ($1\frac{1}{4}$ in.) water with an accuracy of $\pm 2\%$ of span. Install a $\frac{1}{4}$ npt(f) connection in the top portion of the test chamber for the chamber pressure connection.

6.1.9 *Vacuum Gauge*—Dial or digital test gauge meeting the requirements of ASME B40.100 accuracy grade 1A, $\pm 1\%$ of the span. The recommended span is $-100/0$ kPa ($-30/0$ in. Hg). Connect the vacuum gauge to a T-fitting in the abrasive supply line.

6.2 *Balance*, capable of weighing the sample to an accuracy of ± 0.1 g. Used for weighing the abrading media and test specimens. Typically a 2000 to 3000 g capacity balance is required.

7. Test Specimens

7.1 Cut 100 by 100 by 25 mm [4 by 4 by 1 in.] or 114 by 114 by 65 or 76 mm [4.5 by 4.5 by 2.5 or 3 in.] test specimens from refractory brick or shapes or mold them from monolithic refractory materials. Only the most abrasion resistant materials can be 25 mm [1 in.] thick since the test is invalid if a hole is eroded completely through the specimen.

7.2 Mold castable refractories in accordance with Practice C862. Fire specimens to the anticipated service temperature or a higher temperature, if specified, in accordance with Practice C865. One 100 by 100 mm (4 by 4 in.) or 114 by 114 mm (4.5 by 4.5 in.) face of each specimen is a free (not troweled, molded, or cut) face.

7.3 Mold plastic refractories and fire the specimens to the anticipated service temperature or a higher temperature, if specified, in accordance with Test Method C179 (see the sections on apparatus and test specimens). One 100 by 100 mm (4 by 4 in.) or 114 by 114 mm (4.5 by 4.5 in.) face of each specimen is a free (not troweled, molded, or cut) face.

8. Procedure

8.1 Dry the test specimens to a constant weight at 105 to 110°C [220 to 230°F] for a maximum of 4 h before testing.

8.2 Weigh the specimens to the nearest 0.1 g. Determine the volume of the specimens by measurement of length, width, and thickness to the nearest 0.5 mm [0.02 in.] in accordance with the apparatus section of Test Methods C134.

8.3 Place the nominal 100 by 100 mm (~~4~~[4 by 4 in.]in.) or 114 by 114 mm [4.5 by 4.5 in.] face of the test specimens at a 90° angle to the glass nozzle with the surface to be abraded 203 mm [8 in.] from the tip of the glass nozzle. For brick samples test an unbranded surface. For monolithic refractory specimens, test the surface (that is, top free face or bottom mold face) that most accurately reflects the actual field situation. Normally, the free surface is the most appropriate test surface. Position the specimen such that the abrasion pattern is centered on the surface of the plate.

8.4 Turn on the air pressure. Regulate the air pressure to 448 kPa [65 psi]. Check the air pressure before and after the abrading media is run through the system.

8.5 Measure the cabinet pressure using the manometer and maintain the pressure in the chamber at ~~31.8 mm~~31.8 mm [1¼ in.] of water by means of the butterfly valve in the exhaust vent.

8.6 After the air pressure to the gun and the chamber pressure have been adjusted, plug the opening of the gun supply funnel and read the vacuum gauge. If the vacuum gauge does not show a minimum vacuum of 380 mm (15 in.) of mercury, check the position of the glass tubing or the condition of the air-generator nozzle.