



Designation: **F2658 – 07 (Reapproved 2013) F2658 – 07 (Reapproved 2019)**

Standard Specification for Type PSM Poly(Vinyl Chloride) (PVC) SDR 51 and SDR 64 Sewer Pipe and Fittings¹

This standard is issued under the fixed designation F2658; the number immediately following the designation indicates the year of original adoption or, in the case of revision, the year of last revision. A number in parentheses indicates the year of last reapproval. A superscript epsilon (ϵ) indicates an editorial change since the last revision or reapproval.

1. Scope

1.1 This specification covers requirements and test methods for materials, dimensions, workmanship, flattening resistance, impact resistance, pipe stiffness, extrusion quality, joining systems and a form of marking for type PSM poly(vinyl chloride) (PVC) SDR 51 and SDR 64 sewer pipe and fittings.

1.2 Pipe and fittings produced to this specification should be installed in accordance with Practice **D2321**.

1.3 The text of this specification references notes, footnotes, and appendixes which provide explanatory material. These notes and footnotes (excluding those in tables and figures) shall not be considered as requirements of the specification.

1.4 The values stated in inch-pound units are to be regarded as the standard. The values given in parentheses are for information only: mathematical conversions to SI units that are provided for information only and are not considered standard.

1.5 The following precautionary caveat pertains only to the test methods portion, Section 8, of this specification. *This standard does not purport to address all of the safety concerns, if any, associated with its use. It is the responsibility of the user of this standard to establish appropriate safety, health, and environmental practices and determine the applicability of regulatory limitations prior to use.*

1.6 This international standard was developed in accordance with internationally recognized principles on standardization established in the Decision on Principles for the Development of International Standards, Guides and Recommendations issued by the World Trade Organization Technical Barriers to Trade (TBT) Committee.

2. Referenced Documents

2.1 *ASTM Standards:*²

<https://standards.iteh.ai/catalog/standards/sist/30444205-68a3-401b-ab32-5c82ea5f5e99/astm-f2658-072019>

D618 Practice for Conditioning Plastics for Testing

D1600 Terminology for Abbreviated Terms Relating to Plastics

D1784 Specification for Rigid Poly(Vinyl Chloride) (PVC) Compounds and Chlorinated Poly(Vinyl Chloride) (CPVC)

Compounds

D2122 Test Method for Determining Dimensions of Thermoplastic Pipe and Fittings

D2321 Practice for Underground Installation of Thermoplastic Pipe for Sewers and Other Gravity-Flow Applications

D2412 Test Method for Determination of External Loading Characteristics of Plastic Pipe by Parallel-Plate Loading

D2444 Practice for Determination of the Impact Resistance of Thermoplastic Pipe and Fittings by Means of a Tup (Falling

Weight)

D2564 Specification for Solvent Cements for Poly(Vinyl Chloride) (PVC) Plastic Piping Systems

D2749 Symbols for Dimensions of Plastic Pipe Fittings

D2855 Practice for the Two-Step (Primer and Solvent Cement) Method of Joining Poly (Vinyl Chloride) (PVC) or Chlorinated

Poly (Vinyl Chloride) (CPVC) Pipe and Piping Components with Tapered Sockets

D3034 Specification for Type PSM Poly(Vinyl Chloride) (PVC) Sewer Pipe and Fittings

F412 Terminology Relating to Plastic Piping Systems

¹ This specification is under the jurisdiction of ASTM Committee **F17** on Plastic Piping Systems and is the direct responsibility of Subcommittee **F17.62** on Sewer. Current edition approved Feb. 1, 2013; Feb. 1, 2019. Published February 2013; March 2019. Previous edition approved in 2007 as F2658 – 07:07(2013). DOI: 10.1520/F2658-07R13; 10.1520/F2658-07R19.

² For referenced ASTM standards, visit the ASTM website, www.astm.org, or contact ASTM Customer Service at service@astm.org. For *Annual Book of ASTM Standards* volume information, refer to the standard's Document Summary page on the ASTM website.



2.2 Federal Standard:

Fed. Std. No. 123 Marking for Shipment (Civil Agencies)³

2.3 Military Standard:

MIL-STD-129 Marking for Shipment and Storage³

3. Terminology

3.1 Definitions—Definitions are in accordance with Terminology F412, and abbreviations are in accordance with Terminology D1600, unless otherwise specified. The abbreviation of poly(vinyl chloride) plastics is PVC.

3.1.1 The term PSM is not an abbreviation but rather an arbitrary designation for a product having certain dimensions.

4. Significance and Use

4.1 The requirements of this specification are intended to provide pipe and fittings suitable for non-pressure drainage of sewage and surface water.

NOTE 1—Industrial waste disposal lines should be installed only with the specific approval of the cognizant code authority since chemicals not commonly found in drains and sewers and temperatures in excess of 60°C (140°F) may be encountered.

NOTE 2—See D2321 Standard Practice for Underground Installation of Thermoplastic Pipe for Sewers and Other Gravity-Flow Applications for installation recommendations.

5. Basic Materials

5.1 Pipe shall be made of PVC plastic having a cell classification of 12454 or 12364 as defined in Specification D1784.

5.2 Fittings shall be made of PVC plastic having a cell classification of 12454 or 13343 as defined in Specification D1784.

5.3 Pipe and Fitting—Compounds that have different cell classifications, because one or more properties are superior to those of the specified compounds, are also acceptable.

5.4 Rework Material—The manufacturer shall use only his own clean pipe or fitting rework material; the pipe and fittings produced shall meet all the requirements of this specification.

6. Joining Systems

6.1 Solvent Cement Joints for Pipe and Fittings—In the solvent cement joint, the pipe spigot wedges into the tapered socket and the surfaces fuse together. The tapered socket may be a portion of a molded fitting or it may be a belled end of the pipe section. Formed bells shall be concentric with the pipe axis. Fittings meeting the requirements of Specification D3034 shall also be permitted to be used with pipe meeting the requirements of this standard.

6.1.1 The assembly of joints shall be in accordance with Practice D2855.

6.1.2 Joint Tightness—Joints made with pipe and fittings shall show no signs of leakage when tested in accordance with 8.9.

7. Requirements

7.1 Workmanship—The pipe and fittings shall be homogeneous throughout and free from visible cracks, holes, foreign inclusions, or other injurious defects. The pipe shall be as uniform as commercially practical in color, opacity, density, and other physical properties.

7.2 Pipe Requirements:

7.2.1 Diameter—The average outside diameter of the pipe shall meet the requirements given in Table 1 when measured in accordance with 8.4.1.

TABLE 1 Pipe Dimensions

Nominal Size	Outside Diameter		Minimum Wall Thickness	
	Average	Tolerance on Average	SDR 51	SDR 64
3	3.250	±0.008	0.064	0.051
4	4.215	±0.009	0.083	0.066
6	6.275	±0.011	0.123	0.098
8	8.400	±0.012	0.165	0.131
9	9.440	±0.014	0.185	0.148
10	10.500	±0.015	0.206	0.164
12	12.500	±0.018	0.245	0.195
15	15.300	±0.023	0.300	0.239

³ Available from Standardization Documents Order Desk, DODSSP, Bldg. 4, Section D, DLA Document Services, Building 4/D, 700 Robbins Ave., Philadelphia, PA 19111-5098, http://dodssp.daps.dla.mil/19111-5094, http://quicksearch.dla.mil.

NOTE 3—As larger sizes of sewer pipe are needed, it is recommended that they be made with the following outside diameters: 475, 560, and 630 mm.

7.2.2 *Wall Thickness*—Pipe wall thicknesses shall meet the requirements of **Table 1** when measured in accordance with Test Method **D2122** and **8.4.2**. In the case of belled pipe and fittings fabricated from pipe sections, the thickness of the wall in the bell shall be considered satisfactory if it was formed from pipe meeting the preceding requirements.

7.2.3 *Pipe Flattening*—There shall be no evidence of splitting, cracking, or breaking when pipe is tested in accordance with **8.6**.

7.2.4 *Pipe Impact Strength*—The impact strength of the pipe shall not be less than the values given in **Table 2** when tested in accordance with **8.7**.

NOTE 4—This test is intended only for use as a quality control test, not as a simulated service test.

7.2.5 *Pipe Stiffness*—Pipe stiffness values for the pipe shall comply with **Table 3** when tested in accordance with **8.8**.

7.2.6 *Pipe Extrusion Quality*—The pipe shall not flake or disintegrate when tested in accordance with **8.10**.

7.3 *Requirements for Solvent Cemented Pipe and Fittings:*

7.3.1 *Socket Diameter*—The inside diameter of the tapered socket shall comply with the dimensions listed in **Table 4** when determined in accordance with **8.5.1**.

7.3.2 *Socket Depth*—The socket depth shall not be less than that shown in **Table 4** when measured in accordance with **8.5.2**.

7.3.3 *Alternate Fittings*—Fittings meeting the requirements of Specification **D3034** shall also be permitted to be used in joining pipe specified in this standard.

7.3.4 *Spigot Length*—The minimum distance from the spigot end to the area where the spigot diameter changes due to a socket, branch, or change in angle shall comply with the “C” dimension of **Table 4**.

7.4 *Fabricated Fittings*—Any fitting made from pipe or from a combination of pipe and molded parts shall be considered a fabricated fitting and the following provisions shall apply.

7.4.1 *Over-Wrapped Fittings*—Fabricated fittings that have an over-wrap of fiberglass reinforced thermosetting resin or other similar materials shall meet all of the requirements in **7.4.2** and **7.4.3**.

NOTE 5—Refer to **Appendix X3** for geometric configurations of some of the fittings being produced. Consult the individual manufacturer for laying lengths.

7.4.2 *Fabricated Fittings General Requirements:*

7.4.2.1 Pipe used in fabricated fittings shall meet all quality and dimensional requirements listed in the standard for that pipe.

7.4.2.2 Pipe used in fabricated fittings shall have a wall thickness equal to or greater than the wall thickness of the pipes to which the fitting (or that part of the fitting) will be joined.

7.4.2.3 No part of the spur or branch shall protrude into the waterway of the fitting more than 0.070 in.

7.4.2.4 All edges and joints exposed to sewage shall be rounded and free from any rough parts that could catch solids.

7.4.2.5 No fitting shall have an inside diameter dimension smaller than the base inside diameter listed in **Table X1.1** for that pipe size and DR.

7.4.2.6 All welds and solvent cement joints shall be sound and free of visible defects.

7.4.3 *Fabrication Joint Test Requirements—Requirements:*

7.4.3.1 These test requirements apply only to tee, wye, and bend fabricated fittings that are manufactured using fabrication methods that join together a combination of pipe sections or pipe sections and molded parts to form a fitting configuration. Other

TABLE 2 Minimum Pipe Impact Strength at 23°C (73°F)

Pipe Size, in.	Impact Strength, J (ft-lbf)
3	135 (100)
4	203 (150)
6	284 (210)
8	284 (210)
9	299 (220)
10	299 (220)
12	299 (220)
15	299 (220)

TABLE 2 Minimum Pipe Impact Strength at 23°C (73°F)

Pipe Size, in.	Impact Strength, ft-lbf (J)
3	100 (135)
4	150 (203)
6	210 (284)
8	210 (284)
9	220 (299)
10	220 (299)
12	220 (299)
15	220 (299)

TABLE 3 Minimum Pipe Stiffness at 5 % Deflection

Pipe Size, in.	Pipe Stiffness, kPa (psi)	
	SDR 51	SDR 64
3 and 4	99 (14)	49 (7)
6 to 15	99 (14)	49 (7)

TABLE 3 Minimum Pipe Stiffness at 5 % Deflection

Pipe Size, in.	Pipe Stiffness, psi (kPa)	
	SDR 51	SDR 64
3 and 4	14 (99)	7 (49)
6 to 15	14 (99)	7 (49)

TABLE 4 Solvent Cement Socket Dimensions

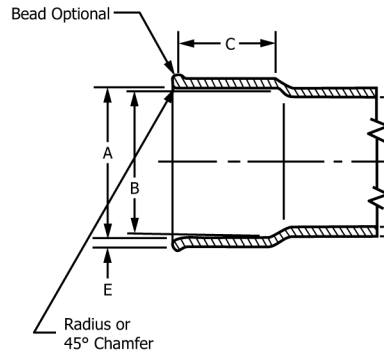

Nominal Size, in.	A	B	C
3	3.271 ± 0.008	3.245 ± 0.008	1.500
4	4.235 ± 0.009	4.210 ± 0.009	1.750
6	6.305 ± 0.011	6.270 ± 0.011	3.000
8	8.424 ± 0.012	8.388 ± 0.012	4.000
9	9.486 ± 0.014	9.426 ± 0.014	4.500
10	10.530 ± 0.015	10.485 ± 0.015	5.000
12	12.536 ± 0.018	12.482 ± 0.018	6.000
15	15.346 ± 0.023	15.277 ± 0.023	7.500

fitting configurations using the same manufacturing procedures as those tested successfully shall be suitable for sale and use. Fittings fabricated from a single-piece of pipe to form Bends and Sweeps shall not be subject to this requirement.

NOTE 6—A brittle fitting may violently fragment during testing. To preclude serious injury or death, suitable and appropriate safety procedures shall be used during any test procedure.

7.4.3.2 Fabricated fittings shall be supported along the fitting centerline on a flat wooden block or blocks as shown in Figs. 1 and 2.

(1) The width of the wooden blocks shall be not less than 66 % of the nominal fitting body size being tested for fabricated fittings up to 18 in. and 12 in. (305 mm) in width for nominal body sizes over 18 in.

(2) The thickness of the wooden blocks shall be neither less than, nor more than 1 in. (25.4 mm) greater than the difference between the largest outside diameter on the bell and the outside of the body being tested.

(3) The wooden blocks shall stop $1 \pm \frac{1}{8}$ in. (25.4 ± 3.2 mm) from the fitting bells and when required for bends shall be mitered as indicated in Fig. 2 so that the wooden blocks cover the entire centerline of the fabricated fitting being tested.

NOTE 7—The wooden blocks shall be made from an available softwood and the type of wood shall be noted on the test report.

NOTE 8—When comparative testing is being performed between labs the same type of softwood blocks shall be used.

7.4.4 Deflect the fabricated fitting by applying the load, calculated from the values given in Table 5 to the body of the fitting as shown in Fig. 1. The body length for this calculation shall not include any part of a taper or transitional area between the fitting body and the bell as shown in Fig. 2. Apply the calculated load at a constant rate over a 1 to 2 min period and then maintain the load for 5 (five) minutes. The calculated load required shall be applied to a second wooden block or blocks that are located along the fitting centerline on top of the fitting as shown in Fig. 2.

7.4.4.1 Inspect all welds and fabrication joints while the load is on the fabricated fitting, and again after the load has been maintained for 5 (five) minutes. Any evidence of cracking, splitting, breaking, or separation shall constitute failure of this requirement.

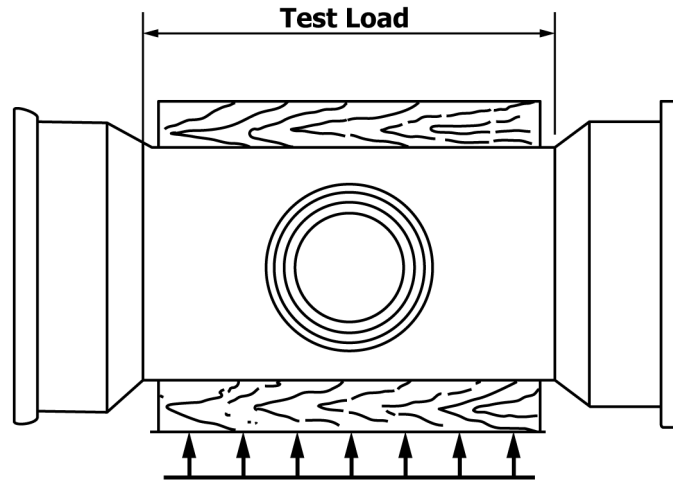

FIG. 1 Deflection Test for Fabricated PVC Fittings

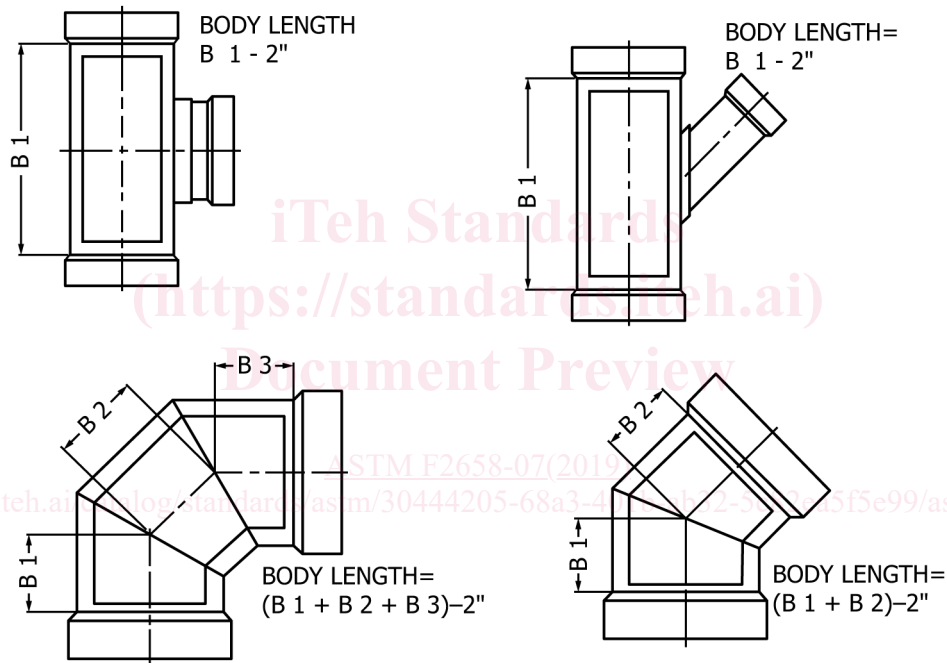

FIG. 2

TABLE 5 Fabricated Fitting Loads, F^A

Fitting Body Pipe Size, in.	F (lb/in. of length)
4	13.3
6	20.0
8	26.7
9	30.0
10	33.3
12	40.0
15	50.0

^A F is the load required to produce 7.5 % deflection in SDR 35 (PS46) PVC pipe.

7.4.4.2 After completing the load test, plug all openings and pressure test at a gage pressure of 10.8 psi (74 kPa) 25-ft head of water for 10 min. Any visible leakage of water at the fabrication joint or through the body constitutes failure to meet this requirement.

NOTE 9—These test requirements have been selected to evaluate quality of fabrication. They are not intended to simulate service conditions or to require testing of every fitting.



7.4.4.3 All tested fittings shall be destroyed. Tested fittings shall not be suitable for sale and/or use.

NOTE 10—If the test samples are to be retained they shall be permanently marked in such a way as to indicate that they have been tested.

7.5 *Solvent Cement*—The cement shall meet the requirements of Specification [D2564](#).

8. Test Methods

8.1 *Conditioning*—Condition the test specimens at $23 \pm 2^\circ\text{C}$ ($73.4 \pm 3.6^\circ\text{F}$) $73.4 \pm 3.6^\circ\text{F}$ ($23 \pm 2^\circ\text{C}$) and $50 \pm 5\%$ relative humidity for not less than 40 h prior to test in accordance with Procedure A of Practice [D618](#), for those tests where conditioning is required.

8.2 *Test Conditions*—Conduct tests in the standard laboratory atmosphere of $23 \pm 2^\circ\text{C}$ ($73.4 \pm 3.6^\circ\text{F}$) ($23 \pm 2^\circ\text{C}$) and $50 \pm 5\%$ relative humidity, unless otherwise specified in the test methods or in this specification.

8.3 *Sampling*—The selection of the sample or samples of pipe or fitting shall be as agreed upon between the purchaser and the seller. In case of no prior agreement, any sample selected by the testing laboratory shall be deemed adequate.

8.4 *Pipe Dimensions:*

8.4.1 *Pipe Diameters*—Measure the average outside diameter of the pipe in accordance with the applicable section of Test Method [D2122](#). Either a tapered sleeve gage or a vernier circumferential wrap tape accurate to $\pm 0.02\text{ mm}$ ($\pm 0.001\text{ in.}$) $\pm 0.001\text{ in.}$ ($\pm 0.02\text{ mm}$) may be used.

8.4.2 *Wall Thickness*—Measure the wall thickness in accordance with the applicable section of Test Method [D2122](#). Make sufficient readings, a minimum of six, to ensure that the minimum thickness has been determined. Use a cylindrical anvil tubing micrometer accurate to $\pm 0.02\text{ mm}$ ($\pm 0.001\text{ in.}$) $\pm 0.001\text{ in.}$ ($\pm 0.02\text{ mm}$).

8.5 *Fittings Dimensions:*

8.5.1 *Socket Diameters*—Measure the inside diameters of the sockets at the entrance and bottom in accordance with the applicable section of Test Method [D2122](#). Calculate the average inside diameters at the entrance and the bottom of the socket by taking the mean of the minimum and maximum values.

8.5.2 *Socket Depth*—Measure the fitting socket depth using a steel rule with at least $\frac{1}{16}\text{ in.}$ (1 mm) $\frac{1}{16}\text{ in.}$ graduations in accordance with the applicable section of Test Method [D2122](#).

8.5.3 *Wall Thickness*—Measure the wall thickness in accordance with the applicable section of Test Method [D2122](#). Make sufficient readings, a minimum of six, to ensure that the minimum thickness has been determined. Use a cylindrical anvil tubing micrometer accurate to $\pm 0.02\text{ mm}$ ($\pm 0.001\text{ in.}$) $\pm 0.001\text{ in.}$ ($\pm 0.02\text{ mm}$).

8.6 *Pipe Flattening*—Flatten three specimens of pipe, 150 mm (6 in.) 6 in. (150 mm) long, between parallel plates in a suitable press until the distance between the plates is 40 % of the outside diameter of the pipe. The rate of loading shall be uniform and such that the compression is completed with 2 to 5 min. Remove the load and examine the specimens for evidence of splitting, cracking, or breaking.

8.7 *Impact Resistance*—Determine the impact resistance of the pipe in accordance with the applicable section of Test Method [D2444](#), using a 20-lb Tup A and the flat plate Holder B. Test six specimens each 150 mm (6 in.) 6 in. (150 mm) long at the impact levels given in [Table 2](#). All shall pass. If one fails, test another six specimens; 11 passes out of 12 tested shall be acceptable.

8.8 *Pipe Stiffness*—Determine the pipe stiffness at 5 % deflection using Test Method [D2412](#). Test three specimens each 150 mm (6 in.) 6 in. (150 mm) long and determine the average pipe stiffness at 5 % deflection. The pipe stiffness shall equal or exceed the minimum value listed in [Table 3](#).

NOTE 11—The 5 % deflection criterion, which was arbitrarily selected for testing convenience, should not be considered as a limitation with respect to in-use deflection. The engineer is responsible for establishing the acceptable deflection limit ([Appendix X1](#)).

8.9 *Joint Tightness*—Join two pieces of pipe by means of a Specification [D3034](#) fitting or socket in accordance with Practice [D2855](#) and using solvent cement as described in [7.5](#). Allow the joined unit to stand 24 h at room temperature. Subject the unit to an internal water pressure of 170 kPa (25 psi) 25 psi (170 kPa) at room temperature for 1 h, and examine the pipe, fitting, and joints for leakage.

8.10 *Extrusion Quality*—Tests shall be run in accordance with Test Method [D2152](#). This procedure is used for determining the extrusion quality of extruded PVC plastic pipe as indicated by reaction to immersion in anhydrous acetone. It is applicable only for distinguishing between unfused and properly fused PVC.

9. Inspection

9.1 Inspection of the material shall be made as agreed upon by the purchaser and the seller as part of the purchase contract.

10. Retest and Rejection

10.1 If the results of any test(s) do not meet the requirements of this specification, the test(s) shall be conducted again only by agreement between the purchaser and the seller. Under such agreement, minimum requirements shall not be lowered, changed, or