



Designation: **E981–04 (Reapproved 2012) E981 – 19**

## Standard Test Method for Estimating Sensory Irritancy of Airborne Chemicals<sup>1</sup>

This standard is issued under the fixed designation E981; the number immediately following the designation indicates the year of original adoption or, in the case of revision, the year of last revision. A number in parentheses indicates the year of last reapproval. A superscript epsilon ( $\epsilon$ ) indicates an editorial change since the last revision or reapproval.

### 1. Scope

1.1 This laboratory test method provides a rapid means of determining sensory irritant potential of airborne chemicals or mixtures. It may also be used to estimate threshold limit values (TLV) for man. However, it cannot be used to evaluate the relative obnoxiousness of odors.

1.2 This test method is intended as a supplement to, not a replacement for, chronic inhalation studies used to establish allowable human tolerance levels.

1.3 *This standard does not purport to address all of the safety concerns, if any, associated with its use. It is the responsibility of the user of this standard to establish appropriate safety, health, and environmental practices and determine the applicability of regulatory limitations prior to use.* Specific hazard information is given in Section 6.

1.4 *This international standard was developed in accordance with internationally recognized principles on standardization established in the Decision on Principles for the Development of International Standards, Guides and Recommendations issued by the World Trade Organization Technical Barriers to Trade (TBT) Committee.*

### 2. Summary of Test Method

2.1 This test method quantitatively measures irritancy as indicated by the reflex inhibition of respiration in mice exposed to sensory irritants.

2.2 Four mice are simultaneously exposed to the airborne chemical. Usually a sufficient number of groups of animals are exposed to a geometric series of concentrations so that a concentration-response curve can be constructed. For simple preliminary comparisons, however, a single group of four animals at one concentration will suffice.

2.3 The mice are placed in a body plethysmograph attached to an exposure chamber so that only the head is exposed to the test material. The plethysmographs are connected to pressure transducers, which sense changes created by inspiration and expiration. The amplified signals are transmitted to a polygraph recorder.

2.4 The concentration of airborne irritant that produces a 50 % decrease in respiratory rate (RD50) is determined from the concentration-response curve constructed from the various data points obtained with a series of concentrations.

### 3. Significance and Use

3.1 This test method was developed to meet the following criteria:

3.1.1 It provides positive recognition of sensory irritants of widely varying potencies.

3.1.2 It is sufficiently simple to permit the testing of large numbers of materials.

3.1.3 This test method is capable of generating concentration-response curves for purposes of compound comparison.

3.1.4 This test method has good reproducibility.

3.2 This test method can be used for a variety of divergent purposes, including the assessment of comparative irritancy of compounds or formulations and setting interim exposure levels for the workplace **(1, 2)**.<sup>2</sup>

3.3 It has been shown that for a wide variety of chemicals and mixtures, a perfect rank order correlation exists between the decreases in respiratory rate in mice and subjective reports of sensory irritation in man **(1, 3, 4, 5)**.

<sup>1</sup> This test method is under the jurisdiction of ASTM Committee E50 on Environmental Assessment, Risk Management and Corrective Action and is the direct responsibility of Subcommittee E50.47 on Biological Effects and Environmental Fate.

Current edition approved Dec. 1, 2012; Feb. 1, 2019. Published December 2012; March 2019. Originally approved 1984. Last previous edition approved in 2004 as E981–04; E981–04(2012). DOI: 10.1520/E0981-04R12.10.1520/E0981-19.

<sup>2</sup> The boldface numbers in parentheses refer to the list of references at the end of this standard.

3.4 A quantitative estimate of the sensory irritancy of a wide variety of materials can be obtained from concentration-response curves developed using this method (1, 3, 4, 6, 7, 8, 9).

3.5 Although this test method is intended to measure sensory irritation of the nasal mucosa, the cornea is innervated by the same nerve. This animal model will, therefore, allow an estimate of the irritant potential of cosmetic ingredients or other household products to the eye, assuming that they can be aerosolized (10).

3.6 This test method is recommended for setting interim guidelines for exposure of humans to chemicals in the workplace, to assess acute sensory irritation resulting from inadvertent spills of household products, and to assess the comparative irritancy of formulations or materials intended for a variety of uses (see Appendix X2).

3.7 This test method will detect irritating effects at concentrations far below those at which pathological changes are observed (9).

NOTE 1—A good overview of the toxicological evaluation of irritant compounds is given in Ref (8).

4. Apparatus

4.1 The apparatus required to perform this test is listed below. The basic components for testing any type of material are the same. A list of suitable apparatus and suppliers is found in Appendix X1.

4.2 Plethysmograph Tubes.

4.3 Exposure Chamber, constructed entirely of glass, with a volume of 2.3 L.

4.4 S.T.103/60 Ground Glass Joint, that allows access to the inside of the exposure chamber.

4.5 Perforated Rubber Dental Dam, reinforced with electrical tape.

4.6 Rubber Stoppers.

4.7 “T” Tube, with a tube 6 cm long and the “T” 12 cm long.

4.8 Vacuum Pump.

4.9 Flowmeter.

4.10 Absolute Filter.

4.11 Sodium Carbonate-Activated Charcoal Filter.

4.12 Pressure Transducer.

4.13 Polygraph Recorders.

4.14 Frequency-to-Voltage Converter, operating in the averaging mode instead of the pulse mode. See Appendix X1.7.

4.15 Voltage Addition and Division Equipment, to obtain the signal average for four mice.

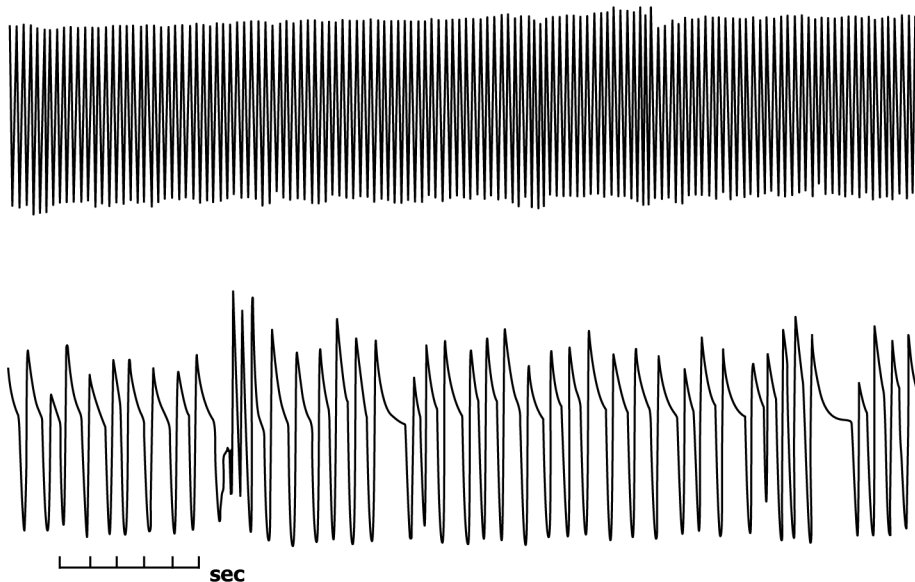

NOTE 1—Taken from Ref. (3).

FIG. 1 Typical Tracing of Normal Mouse Respiration (Top), and of a “Moderate” Sensory Irritant Response (Bottom)

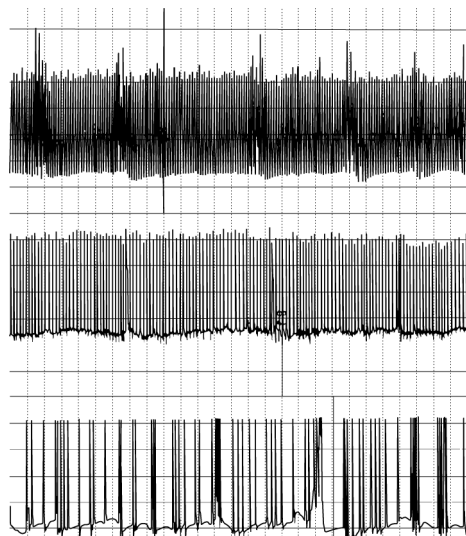

NOTE 1—Taken from Ref. (8).

**FIG. 2 Typical Tracing of Normal Mouse Respiration (Top), a Moderate Pulmonary Irritant Response (Center), and an Extreme Pulmonary Irritant Response (Bottom)**

- 4.16 *Signal Averages.*
- 4.17 *Oscillograph.*
- 4.18 *Aerosol Generator.*
- 4.19 *Timer.*
- 4.20 *Control Valve.*

iTeh Standards  
(<https://standards.iteh.ai>)  
Document Preview

## 5. Reagents

- 5.1 Technical reagents may be used in all tests where solvents other than water are required.
- 5.2 Solutions containing 1 to 3 % of the test material are used for comparative studies.

## 6. Hazards

6.1 Not all compounds that cause a decrease in respiratory rate are sensory irritants. To be characterized as a sensory irritant, a compound must produce a net decrease in respiratory rate as a result of the characteristic pause during expiration as shown in Fig. 1. This pause differentiates sensory irritants from pulmonary irritants, general anesthetics, and asphyxiants, which also reduce respiratory rate, but as a result of a pause between breaths as shown in Fig. 2.

6.2 It is possible for one component to alter the effect of another in a mixture, depending on their respective concentrations (12). Additive and antagonistic responses are possible. For this reason the effects of each compound in a formulation should be assessed before any test is made for interactions.

6.3 Although the test procedure has been found to show a high correlation for sensory irritants with established TLV values for man, it may well predict values that are too high for compounds of low reactivity that are metabolically activated, and also for pulmonary irritants (10).

## 7. Test Animals

7.1 Mice are the subjects to be used for this test. It is imperative that they meet the specifications outlined here. Although any mouse of the proper size could be used, marked differences have been observed between different strains and sexes (2).

7.1.1 Male Swiss-Webster mice shall be used as the test subjects.

7.1.2 Only animals weighing between 22 and 28 g may be used. Smaller mice might be able to crawl into the exposure chamber, while larger ones may not be able to breathe normally in the apparatus.

7.1.3 The same system can be used with guinea pigs or rats with an airflow of 2 L/min when using head dome (9).

## 8. Preparation of Apparatus

8.1 *Exposure Chamber:*

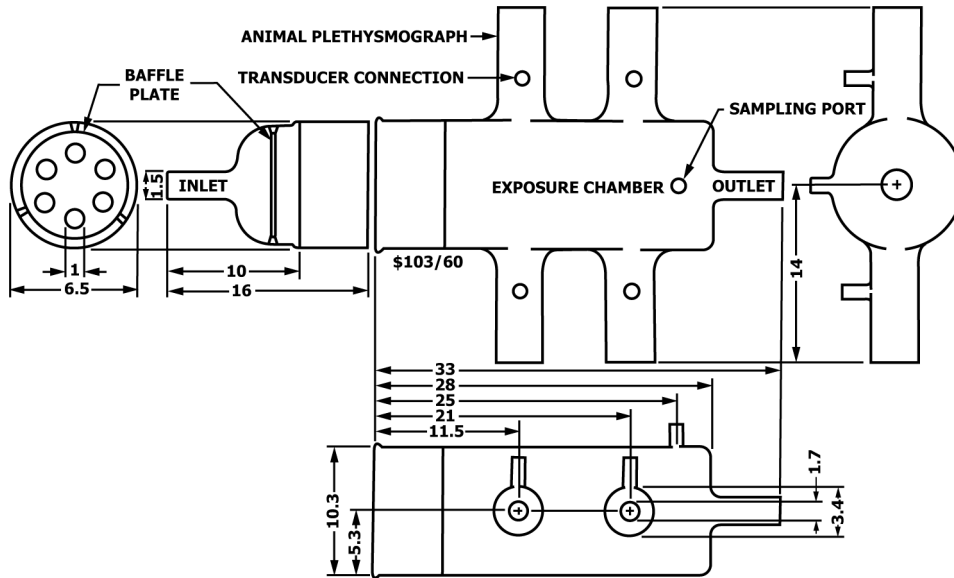

NOTE 1—Dimensions are in centimetres.

NOTE 2—Taken from Ref. (11).

FIG. 3 Glass Exposure Chamber with Attached Body Plethysmographs

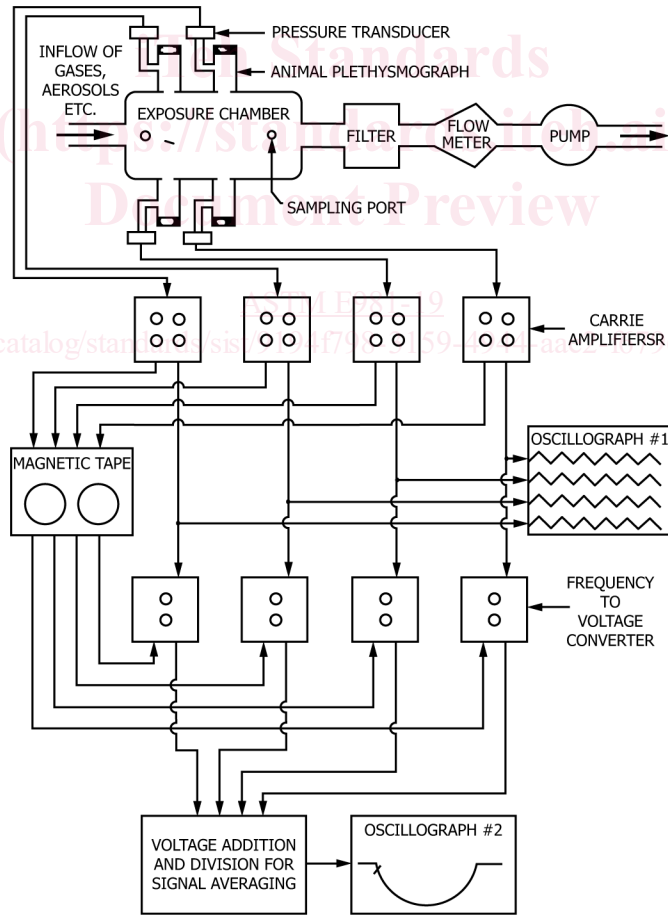

NOTE 1—Taken from Ref. (11).

FIG. 4 Diagram of Test Apparatus

8.1.1 The heads of each of four mice extend into the exposure chamber, and the bodies are contained in plethysmograph tubes. Perforated rubber dental dam reinforced with electrical tape provides tight but comfortable seals around the animals' necks, and rubber stoppers prevent them from backing out of the tubes, and provides an airtight body plethysmograph (see Fig. 3).

8.1.1.1 The "T" tube is of the same diameter as the inlet to the chamber. The gas or aerosol from the generator enters one side of the "T" and the makeup air enters on the other. Thus the tube acts as a miniature mixing chamber, eliminating the need for a baffle plate. The "T" tube is not shown in Fig. 3.

#### 8.1.2 Chamber Equilibration:

8.1.2.1 It is desirable to reach equilibrium of the test material in the exposure chamber in as short a time as possible. In no case should this time exceed one-tenth of the total exposure time. The validity of the data for extrapolation to man requires rapid attainment of maximum concentration.

8.1.2.2 Equilibration time in minutes is 5.0 times the chamber volume in litres divided by airflow through the chamber in litres per minute (13).

8.2 A vacuum pump with a control valve monitored by a flowmeter provides a constant airflow through the exposure chamber. Chamber effluent is passed through an absolute filter and then a sodium carbonate-activated charcoal filter before exhausting, preferably into a fume hood. (See Fig. 4.)

8.3 Each of the four plethysmograph tubes is connected to a pressure transducer. As the mouse inhales, a positive pressure is created and exhalation results in a negative pressure. The amplified signals are recorded on a polygraph, which has the polarity set so that an upward deflection is obtained during inspiration and a downward deflection is obtained during expiration. The signal from each transducer is also fed into a frequency-to-voltage converter, and then fed into a signal averager. The output of the averager is displayed on a second recorder, thus permitting continuous monitoring of the average respiratory rate of the four mice. (See Fig. 4.)

8.4 A suitable generator for this test is a glass Dautrebände-type generator modified to allow continuous feed of test material.<sup>3</sup> This generator can be used for volatile or nonvolatile liquids, solutions, or suspensions of solids. It is depicted schematically in Fig. 5.

8.4.1 For aqueous solutions, liquid is delivered via a pump regulated at 1.0 mL/min to the right-hand tube. This delivery rate can be varied by a factor of 3 to 4. Air is delivered at 10 to 12 psig when a water solution is used, and 8 to 10 psig when acetone solution is used. With acetone the amount of solution delivered is restricted so that no more than 3000 ppm acetone vapor is produced in the exposure chamber. The calculation is made from the total airflow used in the chamber. At the standard flow rate of 20 L/min through the chamber, delivery to the generator of 0.22 mL of acetone per minute will result in a concentration of 2800 to 3000 ppm. With acetone there will be no liquid overflow, but with aqueous solutions, 1.0 mL/min is high enough so that liquid will fall to the bottom of the generator. This is collected in a reservoir via the overflow tube.

8.4.2 Arrows in Fig. 5 indicate the path that the aerosol will follow. Polyethylene Glycol 200 (PEG 200) can be used as a solvent instead of water. The air pressure should be about 20 to 25 psig with this solvent. Dry air must be used with PEG 200, which is hygroscopic. Using this generator with a 1 % solution of test material in water and 20 L/min flow rate through the exposure chamber, the concentration in the chamber will be between 10 to 20 mg/m<sup>3</sup> and most particles will be submicronic.

8.4.3 The Dautrebände-type generator can also be used to vaporize liquids for exposure of animals to vapors. For this purpose, the liquid is delivered at a known rate by a regulated pump and airflow is set at 10 to 20 psig. For liquids of lower vapor pressure, heating tape can be used around the generator to increase vaporization efficiency. For aerosols or vapors likely to oxidize rapidly in air, dry nitrogen should be used instead of air. When this is done, pure oxygen is added to the chamber airflow to maintain 18 to 20 % O<sub>2</sub> in the exposure chamber. When suspensions are to be tested, the suspended material must be very fine to prevent clogging of the tip on the generator. Although larger tips can be used if required, a degradation of aerosolizing performance will result from their use.

8.5 To start and stop test material generation, a timer and an associated control valve are needed in conjunction with the aerosol generator.

8.6 When using water or acetone a "dry" particle will be produced, since both solvents will evaporate. However, PEG 200 will not evaporate and a liquid droplet is obtained. Mass concentration in the chamber should be obtained by sampling on filters and weighing on an appropriate balance. A better method, but one not required in a screening experiment, is appropriate chemical analysis. When acetone is used, its concentration in the chamber should be verified. Indicator tube analysis is adequate, or an infrared analyzer or gas chromatographic analysis can be used.

8.7 Gases are delivered directly into the exposure chamber via an appropriate flowmeter.

8.8 With the exception of the exposure chamber which is essentially a unique piece of apparatus, other parts can be substituted by similar equipment. Also, minicomputers can be used to replace the frequency-to-voltage converter and signal-averaging device. The magnetic tape is not required, and a four-trace oscilloscope with storage capability can replace oscillograph No. 1.

<sup>3</sup> Pitt No. 1 aerosol generator available from Scientific Glassblowing Laboratory, McKees Rocks, PA 15136, has been found suitable.

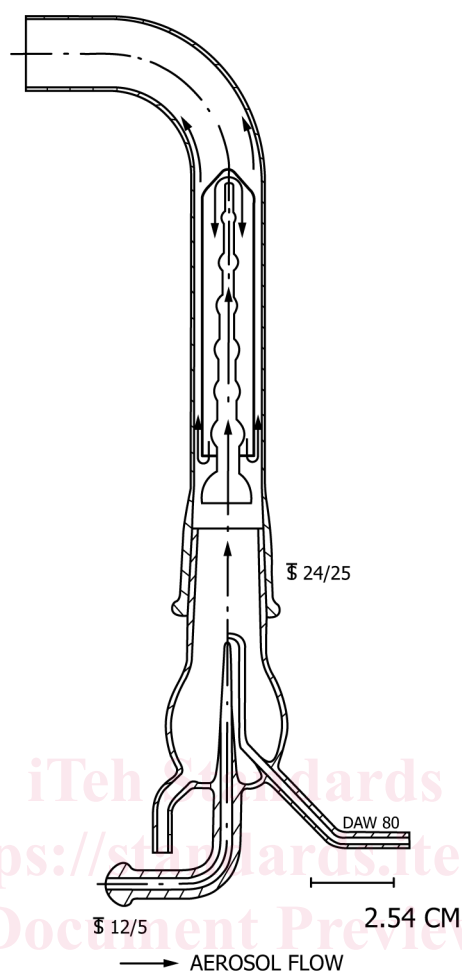

NOTE 1—Taken from Ref. (13).

FIG. 5 Schematic Representation of the Pitt No. 1 Aerosol Generator

<https://standards.iteh.ai/catalog/standards/sist/9194f798-3159-4944-aae2-f6796d0041de/astm-e981-19>

## 9. Sample Preparation

9.1 Because of the large variety of chemicals and formulations that can be tested by this procedure, and the tremendous differences in irritant potential between them, no specific stipulation for sample preparation can be made. The only requirement for concentration is that the levels to be tested are spaced at even logarithmic intervals to allow good concentration-response curves to be generated from the data obtained. The information provided in the succeeding paragraphs of this section is therefore intended for general guidance only.

9.2 For solids and nonvolatile liquids, solutions are prepared in an appropriate solvent. Water and polyethylene glycol 200 (PEG 200) are the most commonly used for this purpose, although 0.1 *N* HCl, 0.1 *N* NaOH, and acetone can also be used. In the case of acetone, which is a mild irritant, the concentration in the chamber should be kept below 3000 ppm to avoid irritation from the solvent.

9.3 As an indication of concentrations to be expected, 1 % aqueous basic, or acidic solutions produce concentrations of 10 to 20 mg/m<sup>3</sup> at an airflow of 20 L/min in the exposure chamber. Polyethylene glycol 200 solutions will produce a concentration of 40 to 50 mg/m<sup>3</sup> of the solute under similar circumstances.

9.4 Gases shall be mixed with room air to produce the desired concentrations.

## 10. Calibration

10.1 In this test method, three parts of the equipment require calibration. Once these calibrations have been made, recalibration is not necessary for the conditions previously used unless the apparatus is disassembled.

10.2 *Generator*—Determine the particle size of the aerosol droplets emitted by each generator for each type of solution or suspension to assure the validity of the tests. A 1 % aqueous solution under 10 to 12 psig will produce particles of aerodynamic equivalent diameter of 0.6 to 0.8 μm, with a geometric standard deviation of 2.0 to 2.5. With PEG 200 at a pressure of 20 to 25