



Standard Specification for Polyethylene (PE) Large Diameter Profile Wall Sewer and Drain Pipe¹

This standard is issued under the fixed designation F894; the number immediately following the designation indicates the year of original adoption or, in the case of revision, the year of last revision. A number in parentheses indicates the year of last reapproval. A superscript epsilon (ϵ) indicates an editorial change since the last revision or reapproval.

1. Scope*

1.1 This specification covers requirements and test methods for materials, dimensions, workmanship, ring stiffness, flattening, joint systems, and a form of marking for large diameter, 10 to 132 in. (250 to 3355 mm), inside diameter based polyethylene (PE) pipe of profile wall construction and with bell and spigot, heat fusion, extrusion welded or electrofusion joints for use in gravity flow applications, such as for sewers and drains.

NOTE 1—Pipe produced to this specification should be installed in accordance with Practice D2321 and with the manufacturer's recommendations.

1.2 The values stated in inch-pound units are to be regarded as standard. The values given in parentheses are mathematical conversions to SI units that are provided for information only and are not considered standard.

1.3 The following safety hazards caveat pertains only to the test method portion, Section 8, of this specification: *This standard does not purport to address all of the safety concerns, if any, associated with its use. It is the responsibility of the user of this standard to establish appropriate safety, health, and environmental practices and determine the applicability of regulatory limitations prior to use.*

1.4 *This international standard was developed in accordance with internationally recognized principles on standardization established in the Decision on Principles for the Development of International Standards, Guides and Recommendations issued by the World Trade Organization Technical Barriers to Trade (TBT) Committee.*

2. Referenced Documents

2.1 ASTM Standards:²

D618 Practice for Conditioning Plastics for Testing

¹ This specification is under the jurisdiction of ASTM Committee F17 on Plastic Piping Systems and is the direct responsibility of Subcommittee F17.26 on Olefin Based Pipe.

Current edition approved Feb. 1, 2019. Published March 2019. Originally approved in 1985. Last previous edition approved in 2013 as F894–13. DOI: 10.1520/F0894-19.

² For referenced ASTM standards, visit the ASTM website, www.astm.org, or contact ASTM Customer Service at service@astm.org. For *Annual Book of ASTM Standards* volume information, refer to the standard's Document Summary page on the ASTM website.

D1600 Terminology for Abbreviated Terms Relating to Plastics

D2122 Test Method for Determining Dimensions of Thermoplastic Pipe and Fittings

D2321 Practice for Underground Installation of Thermoplastic Pipe for Sewers and Other Gravity-Flow Applications

D2412 Test Method for Determination of External Loading Characteristics of Plastic Pipe by Parallel-Plate Loading

D2837 Test Method for Obtaining Hydrostatic Design Basis for Thermoplastic Pipe Materials or Pressure Design Basis for Thermoplastic Pipe Products

D3212 Specification for Joints for Drain and Sewer Plastic Pipes Using Flexible Elastomeric Seals

D3350 Specification for Polyethylene Plastics Pipe and Fittings Materials

F412 Terminology Relating to Plastic Piping Systems

F477 Specification for Elastomeric Seals (Gaskets) for Joining Plastic Pipe

F585 Guide for Insertion of Flexible Polyethylene Pipe Into Existing Sewers

F1290 Practice for Electrofusion Joining Polyolefin Pipe and Fittings

F2620 Practice for Heat Fusion Joining of Polyethylene Pipe and Fittings

2.2 Federal Standard:

Fed. Std. No. 123 Marking for Shipment (Civil Agencies)³

2.3 Military Standard:

MIL-STD-129 Marking for Shipment and Storage³

3. Terminology

3.1 *Definitions*—Definitions are in accordance with Terminology F412 and abbreviations are in accordance with Terminology D1600, unless otherwise specified. The abbreviation for polyethylene is PE.

3.2 *Definitions of Terms Specific to This Standard:*

3.2.1 *closed profile (CP)*—a profile wall pipe wall construction that presents an essentially smooth internal and external surface that is formed by a solid core wall pipe with thermoplastic pipe reinforcement, or by the spiral winding of a structural thermoplastic profile.

³ Available from Standardization Documents Order Desk, Bldg. 4 Section D, 700 Robbins Ave., Philadelphia, PA 19111-5094, Attn: NPODS.

*A Summary of Changes section appears at the end of this standard

3.2.2 *extrusion welding*—a joining technique that is accomplished by extruding a molten polyethylene bead between two prepared surface ends.

3.2.3 *gravity flow, n*—for the purposes of the specification, gravity flow means a piping system flowing less than full, except during storms or high flow conditions when the system may become surcharged in which case, the system is subject to temporary internal hydrostatic pressure that is limited to joint capabilities. See Section 7.

3.2.4 *open profile (OP)*—a profile wall pipe wall construction that presents an essentially smooth internal surface with a ribbed or corrugated external surface. The wall of the pipe is reinforced with round or rectangular profiles.

3.2.5 *profile wall*—a pipe wall construction that presents an essentially smooth surface in the waterway but includes other shapes, which can be either solid or hollow, that help brace the pipe against diametrical deformation (see Fig. 1).

3.2.6 *ring stiffness constant (RSC)*—the value obtained by dividing the parallel plate load in pounds per foot of pipe length, by the resulting deflection, in percent, at 3 % deflection. The ring stiffness constant (RSC) that is used in this specification to classify pipe is a measure of the pipe’s deformation resistance to diametrical point loading, such as is experienced during handling and installation. A pipe should resist these loads sufficiently well to allow its installation to prescribed deflection limits.

4. Classifications and Uses

4.1 *Uses*—The requirements of this specification are intended to provide pipe suitable for underground or overground gravity flow drainage of sewage, surface water, and industrial waste.

NOTE 2—Industrial waste disposal lines should be installed only upon the specific approval of the governing code, or other authority, and after determining the suitability of the product under the anticipated environment, temperature, and other end-use conditions. Users should consult the manufacturer for the required product information.

4.2 *Classifications*—This specification covers PE profile wall pipe products made in six standard ring stiffness constant (RSC) classifications, namely 40, 63, 100, and 160, 250 and 400. These are referred to as RSC 40, RSC 63, RSC 100, RSC 160, RSC 250 and RSC 400.

NOTE 3—Other RSC classifications may be supplied, as agreed upon between the purchaser and the manufacturer, provided that such product complies in every other respect with the applicable dimensional tolerances and testing requirements of this specification.

4.3 *Pipe Ends and Joining Systems*: Joints intended for sewer applications shall be watertight. They shall meet the requirements of Test Method D3212. Joints intended for drainage applications shall be sand/silt tight.

4.3.1 *Bell and Spigot, Gasketed Type*—The bell and spigot are formed on the pipe or welded to the pipe. Seal is made by a gasket compressed between the spigot and billed ends of the pipe (see Fig. 2).

4.3.2 *Bell and Spigot, Extrusion Weld Type*—The bell and spigot are formed on the pipe or welded to the pipe. Seal is made by extrusion welding (3.2.2) of the bell and spigot pipe ends (see Fig. 3).

4.3.3 *Heat Fusion*—Heat fusion joints are in accordance with Practice F2620. Seal is made by joining molten pipe ends under controlled temperature and pressure (see Fig. 4).

4.3.4 *Plain End Extrusion Weld*—Seal is effected by extrusion welding prepared plain ends of the pipe (see Fig. 5).

4.3.5 *Spiral Wound Plain End*—Seal is made by extrusion welding on the ID side, or the OD side, or both, of the prepared plain ends at the termination of the spiral winding. (see Fig. 6).

4.3.6 *Electrofusion Bell & Spigot*—The seal is made by electrofusion joining through an integral electrofusion device built into the spigot end of the pipe. The spigot is inserted into the socket (or bell) and current applied to the contacts.

4.3.7 *Electrofusion Coupling*—The seal is made by electrofusion joining through a separate electrofusion coupling or fitting. The electrofusion fitting may be an enlarged OD coupler, a reduced ID coupler, or an equal OD/ID internal coupler.

4.3.8 *Threaded Joint*—The pipe ends are threaded with male and female threads on opposite ends of the pipe. These joints are considered to be sand/silt tight. (see Fig. 7)

4.3.9 *External Coupler*—Only couplers supplied or recommended by the manufacturer shall be used.

4.3.10 *Other*—Where these connections are impractical or undesirable because of space, layout, or other requirement, joining methods such as flanging, restrained integral connectors, and others may be used. Methods proposed should be evaluated by the engineer for suitability.

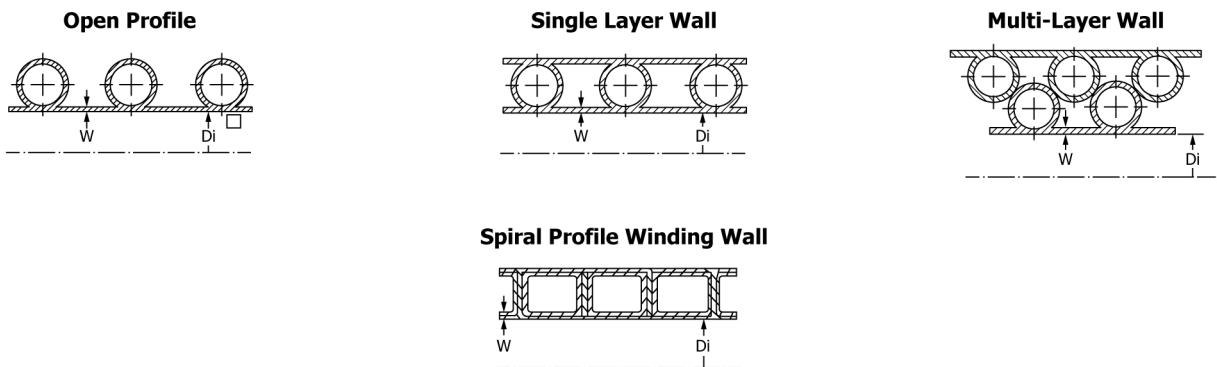

FIG. 1 Typical Construction of Profile Wall PE Pipe

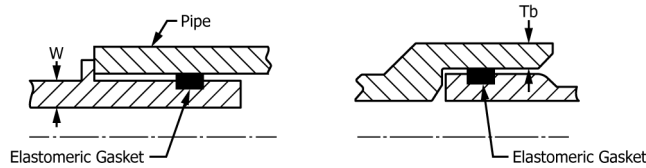

FIG. 2 Typical Bell and Spigot, Gasketed Type Joint Constructions

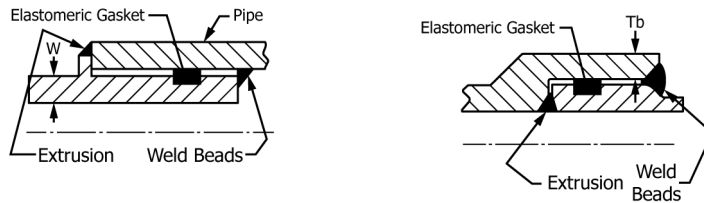

FIG. 3 Typical Bell and Spigot, Extrusion Weld Type Joint Constructions

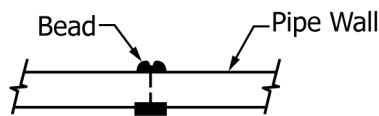

FIG. 4 Heat Fusion

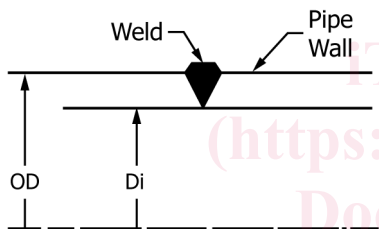

FIG. 5 Plain End Extrusion Weld

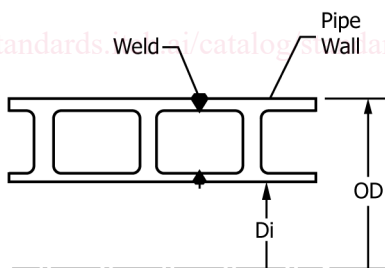

FIG. 6 Spiral Wound Plain End

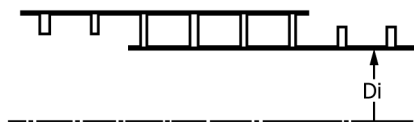

FIG. 7 Threaded Joint

5. Materials

5.1 *Base Materials*—All exposed surfaces of the pipe shall be made of PE plastic compound meeting the requirements of cell classification PE 334433C (or E) or higher cell classification in accordance with Specification D3350. The material shall have an established hydrostatic design basis (HDB) of not

less than 1250 psi (8.6 MPa) for water at 73.4 °F (23 °C) determined in accordance with Test Method D2837.

NOTE 4—A source of hydrostatic design basis (HDB) recommendations for commercial thermoplastic pipe materials is the Plastics Pipe Institute.⁴ These are developed on the basis of Test Method D2837 and additional requirements. A listing of recommended HDB's and the criteria for development may be obtained from the Plastics Pipe Institute.

5.2 *Other Pipe Materials*—Thermoplastic materials other than those specified under base materials may be used as part of the profile construction, for example, as a core tube to support the shape of the profile during processing, or as an inner layer in a multi-layer profile winding in a closed profile pipe, provided that these materials are compatible with the base PE material, are completely encapsulated in the finished product (are contained within the ID and OD surfaces of the pipe), and in no way compromise the performance of the PE pipe products in the intended use.

5.3 *Rework Material*—Clean rework PE material generated from the manufacturer's own pipe production may be used by the same manufacturer provided the pipe produced meets all the requirements of this specification. Rework material of the type described in 5.2, may only be used to make product if it has been shown to be compatible with the base PE material and allows the production of pipe that meets all the performance requirements of this specification.

5.4 *Gaskets*—Elastomeric gaskets shall comply with the requirements specified in Specification F477.

5.5 *Lubricant*—The lubricant used for assembly of gasket joints shall have no detrimental effect on the gasket or on the pipe.

5.6 *Extrusion Welding Material*—The material used for extrusion welding the pipe material shall meet the requirements established for the base material.

6. Joining System

6.1 *Bell and Spigot* (See Fig. 2 and Fig. 3):

6.1.1 The pipe ends shall consist of integrally formed bell and spigot, one of which is designed to accommodate a gasket,

⁴ Plastics Pipe Institute, 105 Decker Court, Suite 825, Irving, TX 75062

which when assembled, complies with the requirements of Test Method **D3212**, and forms a watertight seal by the radial compression of the gasket between the spigot and the bell ends. Alternatively, the pipe ends may act as either spigot or bell to an externally supplied coupling.

6.1.2 The joint shall be designed to avoid displacement of the gasket when it is assembled in accordance with the manufacturer's recommendations.

6.1.3 The assembly of the gasket joints shall be in accordance with the manufacturer's recommendations.

6.2 *Bell and Spigot Extrusion Weld Type (See Fig. 2 and Fig. 3):*

6.2.1 The pipe ends shall consist of an integrally formed bell and spigot which, when assembled, come together to form an interface between bell and spigot, such that it is suitable for permanent sealing by the extrusion welding process, in accordance with the manufacturer's recommended procedure. Alternatively, the pipe ends may act as either spigot or bell to an externally supplied coupling that is permanently sealed by the extrusion welding process.

6.2.2 Permanently sealed joints may be effected by welding from inside the pipe or outside, or both.

6.2.3 The assembly of the welded joints shall be in accordance with the manufacturer's recommendations.

6.3 *Heat Fusion (See Fig. 4):*

6.3.1 The pipe ends shall be plain and suitable for machine facing to square.

6.3.2 The assembly of the joint shall be in accordance with Practice **F2620** and the manufacturer's recommendations.

6.4 *Extrusion Welding Plain End (See Fig. 5):*

6.4.1 The pipe wall at the ends shall be chamfered to create suitable fillet weld geometry.

6.4.2 Permanently sealed joints may be effected by welding from inside the pipe or outside, or both.

6.4.3 The assembly of the welding joints shall be in accordance with the manufacturer's recommendations.

6.5 *Spiral Wound Plain End (See Fig. 6):*

6.5.1 The pipe wall at the ends shall be chamfered to create suitable fillet weld geometry.

6.5.2 Permanently sealed joints may be made by welding from inside the pipe or outside, or both.

6.5.3 The assembly of the welding joints shall be in accordance with the manufacturer's recommendations.

6.6 *Bell and Spigot or Coupling Electrofusion Joint:*

6.6.1 The bell and spigot joint shall consist of an integral electrofusion device built into the spigot and a plain socket or bell end, which come together to form an electrofusion joint with the proper application of electrical current for an appropriate time period.

6.6.2 The coupling, the joint may consist of two prepared straight pipe ends (spigot ends) and a separate OD, ID, or internal electrofusion coupling, which come together to form an electrofusion joint with the proper application of electrical current for an appropriate time period.

6.6.3 The assembly of the electrofusion joint shall be in accordance Practice **F1290** and with the manufacturers recommendations.

6.7 *Threaded Joint (See Fig. 7):*

6.7.1 A part of the pipe wall at the ends shall be removed on the OD side of the closed profile wall to create male threads, or removed on the ID side of the closed profile wall to create female threads.

6.7.2 The assembly of the threaded joints shall be in accordance with the manufacturer's recommendations.

7. Requirements

7.1 *Appearance*—When viewed without magnification the following requirements apply:

7.1.1 Visible surfaces of the pipe shall be smooth, clean and free from grooving, blistering, visible impurities or pores and any other surface irregularities likely to prevent conformity to the standard.

7.1.2 Pipe ends shall be cleanly cut square to the axis of the pipe, and within any cutting zone recommended by the manufacturer, or according to the profile geometry as specified by the manufacturer.

7.1.3 Edges on spirally formed pipes which become sharp when cut, shall be rounded off.

7.2 *Pipe Requirements:*

7.2.1 *Diameter*—The average inside diameter of the pipe, including the diameter in integral spigot sections where present, shall meet the requirements given in **Table 1** or **Table 2**, when measured in accordance with **8.4.1**.

7.2.2 *Pipe Wall Thickness*—The minimum wall thickness of the waterway of the pipe (see **Fig. 1**) shall meet the requirements given in **Table 1** or **Table 2**, when measured in accordance with **8.4.2**.

7.2.3 *Bell and Spigot Wall Thickness*—With the exception of the tapered lead-in section, where present, the minimum wall thickness in the bell of the pipe (see **Fig. 1**) shall meet the values specified in **Table 1** or **Table 2**. The minimum wall thickness of the thinnest section of the spigot shall not be less than that established for the pipe waterway.

7.2.4 *Laying Length*—Standard pipe laying length, measured from the bottom of the bell to the tip of the spigot (see **Fig. 1**), shall be 20 ft (6.1 m) when measured in accordance with Test Method **D2122**. Other laying lengths shall be as agreed upon between the purchaser and the manufacturer. The tolerance on the laying length shall be ± 2 in. (50 mm). For pipe with an integral bell, the pipe laying length is measured from the bottom of the bell to the tip of the spigot.

7.3 *Ring Stiffness Constant*—Ring stiffness constant (RSC) for the pipe between bell and spigot sections shall comply with the minimum values given in **Table 3**, when tested in accordance with **8.5.1** or with the corresponding values established by statistical correlation, developed by the manufacturer and agreed by the purchaser, when measured in accordance with **8.5.2**. However, in cases of disagreement the pipe shall comply with the values in **Table 3**, when tested in accordance with **8.5.1**. Where an integral bell is present, the RSC for the pipe is determined between bell and spigot sections.

7.4 *Flattening*—There shall be no evidence of splitting, cracking, or breaking when pipe, including the bell or spigot section, is tested in accordance with **8.6**.

TABLE 1 Open Profile Pipe Dimensions and Tolerances

Nominal Pipe Size, in. (mm)	Average Inside Diameter, in. (mm)	Tolerance on Average Inside Diameter, in. (mm)	Min Wall Thickness in Pipe Waterway, <i>W</i>				Min Bell Thickness, <i>T_b</i> , in. (mm)
			RSC 40, in. (mm)	RSC 63, in. (mm)	RSC 100, in. (mm)	RSC 160 and higher, in. (mm)	
18 (460)	18.00 (457.2)	±0.38 (9.7)	0.18 (4.6)	0.18 (4.6)	0.18 (4.6)	0.22 (5.6)	0.70 (17.8)
19.5 (495)	19.5 (495.3)	±0.38 (9.7)	0.18 (4.6)	0.18 (4.6)	0.18 (4.6)	0.24 (6.1)	0.70 (17.8)
21 (530)	21.00 (533.4)	±0.38 (9.7)	0.18 (4.6)	0.18 (4.6)	0.18 (4.6)	0.24 (6.1)	0.70 (17.8)
24 (610)	24.00 (609.6)	±0.38 (9.7)	0.18 (4.6)	0.18 (4.6)	0.22 (5.6)	0.24 (6.1)	0.70 (17.8)
27 (690)	27.00 (685.8)	±0.38 (9.7)	0.18 (4.6)	0.18 (4.6)	0.24 (6.1)	0.24 (6.1)	0.70 (17.8)
30 (760)	30.00 (762.0)	±0.38 (9.7)	0.18 (4.6)	0.22 (5.6)	0.24 (6.1)	0.26 (6.6)	0.70 (17.8)
33 (840)	33.00 (838.2)	±0.38 (9.7)	0.18 (4.6)	0.24 (6.1)	0.24 (6.1)	0.30 (7.6)	0.95 (24.1)
36 (910)	36.00 (914.4)	±0.38 (9.7)	0.18 (4.6)	0.24 (6.1)	0.26 (6.6)	0.30 (7.6)	1.05 (26.7)
42 (1070)	42.00 (1066.8)	±0.42 (10.7)	0.24 (6.1)	0.24 (6.10)	0.30 (7.6)	0.38 (9.7)	1.15 (29.2)
48 (1220)	48.00 (1219.2)	±0.48 (12.2)	0.24 (6.1)	0.26 (6.6)	0.30 (7.6)	0.38 (9.7)	1.25 (31.8)
54 (1370)	54.00 (1371.6)	±0.54 (13.7)	0.24 (6.1)	0.30 (7.6)	0.38 (9.7)	0.42 (10.7)	1.25 (31.8)
60 (1520)	60.00 (1524.0)	±0.60 (15.2)	0.26 (6.6)	0.30 (7.6)	0.38 (9.7)	0.52 (13.2)	1.30 (33.0)
66 (1680)	66.00 (1676.4)	±0.66 (16.8)	0.30 (7.6)	0.38 (9.7)	0.42 (10.7)	0.67 (17.0)	1.30 (33.0)
72 (1830)	72.00 (1828.8)	±0.72 (18.3)	0.30 (7.6)	0.38 (9.7)	0.42 (10.7)	0.90 (22.9)	1.30 (33.0)
78 (1980)	78.00 (1981.2)	±0.78 (19.8)	0.30 (7.6)	0.38 (9.7)	0.52 (13.2)	0.90 (22.9)	1.35 (34.3)
84 (2130)	84.00 (2133.6)	±0.84 (21.3)	0.38 (9.7)	0.42 (10.7)	0.67 (17.0)	0.90 (22.9)	1.35 (34.3)
90 (2290)	90.00 (2286.0)	±0.90 (22.9)	0.38 (9.7)	0.42 (10.7)	0.90 (22.9)	0.95 (24.1)	1.35 (34.3)
96 (2440)	96.00 (2438.4)	±0.96 (24.4)	0.38 (9.7)	0.52 (13.2)	0.90 (22.9)	0.95 (24.1)	1.35 (34.3)
108 (2740)	108.00 (2743.2)	±1.08 (27.4)	0.42 (10.7)	0.67 (17.0)	0.90 (22.9)	0.95 (24.1)	1.35 (34.3)
120 (3050)	120.00 (3048.0)	±1.20 (30.5)	0.52 (13.2)	0.67 (17.0)	0.90 (22.9)	0.95 (24.1)	1.35 (34.3)
132 (3355)	132.00 (3352.8)	±1.32 (33.5)	0.52 (13.2)	0.67 (17.0)	0.90 (22.9)	0.95 (24.1)	1.35 (34.3)

TABLE 2 Closed Profile Pipe Dimensions and Tolerances

Nominal Pipe Size, in. (mm)	Average Inside Diameter, in. (mm)	Tolerance on Average Inside Diameter, in. (mm)	Min Wall Thickness in Pipe Waterway, <i>W</i> , All RSC, in. (mm)		Min Bell Thickness, <i>T_b</i> , in. (mm)
			RSC 40	RSC 63	
10 (250)	10.0 (254.0)	±0.38 (9.7)	0.18 (4.6)	0.18 (4.6)	0.5 (13)
12 (300)	12.0 (304.8)	±0.38 (9.7)	0.18 (4.6)	0.18 (4.6)	0.5 (13)
15 (380)	15.0 (381.0)	±0.38 (9.7)	0.18 (4.6)	0.18 (4.6)	0.5 (13)
18 (460)	18.0 (457.2)	±0.38 (9.7)	0.18 (4.6)	0.18 (4.6)	0.5 (13)
19.5 (495)	19.5 (495.3)	±0.38 (9.7)	0.18 (4.6)	0.18 (4.6)	0.5 (13)
21 (530)	21.0 (533.4)	±0.38 (9.7)	0.18 (4.6)	0.18 (4.6)	0.5 (13)
24 (610)	24.0 (609.6)	±0.38 (9.7)	0.18 (4.6)	0.18 (4.6)	0.5 (13)
27 (690)	27.0 (685.8)	±0.38 (9.7)	0.18 (4.6)	0.18 (4.6)	0.5 (13)
30 (760)	30.0 (762.0)	±0.38 (9.7)	0.18 (4.6)	0.18 (4.6)	0.5 (13)
33 (840)	33.0 (838.2)	±0.38 (9.7)	0.18 (4.6)	0.18 (4.6)	0.5 (13)
36 (910)	36.0 (914.4)	±0.38 (9.7)	0.18 (4.6)	0.18 (4.6)	0.5 (13)
40 (1020)	40.0 (1016.0)	±0.38 (9.75)	0.18 (4.6)	0.18 (4.6)	0.5 (13)
42 (1070)	42.0 (1066.8)	±0.42 (10.7)	0.18 (4.6)	0.18 (4.6)	0.5 (13)
48 (1220)	48.0 (1219.2)	±0.48 (12.2)	0.18 (4.6)	0.18 (4.6)	0.5 (13)
54 (1370)	54.0 (1371.6)	±0.54 (13.7)	0.18 (4.6)	0.18 (4.6)	0.5 (13)
60 (1520)	60.0 (1524.0)	±0.60 (15.2)	0.18 (4.6)	0.18 (4.6)	0.6 (15)
66 (1680)	66.0 (1676.4)	±0.66 (16.8)	0.18 (4.6)	0.18 (4.6)	0.6 (15)
72 (1830)	72.0 (1828.8)	±0.72 (18.3)	0.18 (4.6)	0.18 (4.6)	0.6 (15)
78 (1980)	78.0 (1981.2)	±0.78 (19.8)	0.18 (4.6)	0.18 (4.6)	0.6 (15)
84 (2130)	84.0 (2133.6)	±0.84 (21.3)	0.18 (4.6)	0.18 (4.6)	0.7 (18)
90 (2290)	90.0 (2286.0)	±0.90 (22.9)	0.18 (4.6)	0.18 (4.6)	0.7 (18)
96 (2440)	96.0 (2438.4)	±0.96 (24.9)	0.18 (4.6)	0.18 (4.6)	0.7 (18)
102 (2590)	102.0 (2590.8)	±1.02 (25.9)	0.18 (4.6)	0.18 (4.6)	0.7 (18)
108 (2740)	108.0 (2743.2)	±1.08 (27.4)	0.18 (4.6)	0.18 (4.6)	0.7 (18)
114 (2900)	114.0 (2895.6)	±1.14 (29.0)	0.18 (4.6)	0.18 (4.6)	0.8 (20)
120 (3050)	120.0 (3048.0)	±1.20 (30.5)	0.18 (4.6)	0.18 (4.6)	0.8 (20)
126 (3200)	126.0 (3200.4)	±1.26 (32.0)	0.18 (4.6)	0.18 (4.6)	0.8 (20)
132 (3355)	132.0 (3352.8)	±1.32 (33.5)	0.18 (4.6)	0.18 (4.6)	0.8 (20)
138 (3510)	138.0 (3505.2)	±1.38 (35.1)	0.18 (4.6)	0.18 (4.6)	0.8 (20)

TABLE 3 Minimum Ring Stiffness Constant (RSC) Values

Nominal Pipe Classification	RSC (lb/ft of Length)
40	36
63	56
100	90
160	144
250	225
400	360

7.5 Joint Requirements:

7.5.1 Bell and spigot connections, whether gasket style or thermal weld type when joined in accordance with the manufacturer's recommendations, shall show no sign of leakage when tested in accordance with 8.7. In the case of gasket type, all surfaces of the joint upon which the gasket may bear, shall be smooth and free of such imperfections, ridges, fractures, or cracks that could adversely affect sealability.

NOTE 5—Testing for joint tightness is not intended to be a routine quality control test. The test is intended to qualify pipe joint designs to a specified level of performance.

7.5.2 Heat fusion connections shall be inspected and compared against the butt fusion bead visual inspection acceptance guideline in Fig. 4 of Practice F2620.

7.5.3 Thermal weld connections shall be tested in accordance with 8.7 with the exception that the load be applied relative to the centerline of the wall. No leakage is allowed.

7.5.4 Electrofusion joints joined in accordance with the manufacturer's recommendations shall show no sign of leakage when tested in accordance with 8.7. For service applications where the head pressure exceeds 25 feet of water pressure, consult the manufacturer for their qualification test results and recommendations.

7.5.5 For joining systems where Test Method D3212 does not apply and for service applications where the surcharge hydrostatic pressure exceeds 25 ft of head, consult the manufacturer for their joint qualification test results and recommendations.

7.6 Gaskets:

7.6.1 Gaskets shall meet the requirements of Specification F477 and be molded into a circular form or extruded to the proper section, then spliced into circular form, and shall be made of a properly cured high grade elastomeric compound.

7.6.2 The basic polymer shall be natural rubber, synthetic elastomer, or a blend of both.

7.6.3 The gasket shall be designed with an adequate compressive force, so as to effect a positive seal under all combinations of joint tolerances.

8. Test Methods

8.1 Conditioning:

8.1.1 *Referee Testing*—When conditioning is required for referee tests, condition the specimens in accordance with Procedure A of Methods D618 at $73.4 \pm 3.6^\circ\text{F}$ ($23 \pm 2^\circ\text{C}$) without regard to relative humidity for not less than 40 h prior to test. Conduct tests under the same conditions of temperature and humidity, unless otherwise specified.

8.1.2 *Quality Control Testing*—Unless otherwise specified, condition specimens for a minimum of 4 h prior to test in air or 1 h in water at $73.4 \pm 3.6^\circ\text{F}$ ($23 \pm 2^\circ\text{C}$). Test the specimens at $73.4 \pm 3.6^\circ\text{F}$ without regard to relative humidity.

8.2 *Test Conditions*—Conduct tests other than those for routine quality control purposes in the Standard Laboratory Atmosphere of $73.4 \pm 3.6^\circ\text{F}$ ($23 \pm 2^\circ\text{C}$) without regard to relative humidity, unless otherwise specified in the referenced test method or in this specification. In cases of disagreement, retesting shall be conducted with the temperature and relative humidity tolerances limited to $\pm 1.8^\circ\text{F}$ (1°C) and $\pm 2\%$ respectively.

8.3 *Sampling*—The selection of samples of the pipe shall be as agreed upon between the purchaser and the seller. In case of no prior agreement, any sample selected by the testing laboratory shall be deemed adequate.

8.4 Dimensions:

8.4.1 *Average Inside Diameter*—Measure the inside diameter with any suitable device accurate to within $\pm \frac{1}{32}$ 1/32 in. (0.8mm) at 4 approximately equally spaced locations in the circumferential direction for sizes NPS 48 and smaller, and 6 locations for sizes larger than NPS 48, and calculate the average diameter as the arithmetic mean of diameters measured.

8.4.2 *Wall Thickness*—Measure the wall thickness in accordance with the requirements of Test Method D2122. Make sufficient readings, a minimum of 8, around the circumference to ensure that the minimum thickness has been determined. Use of a properly calibrated ultrasonic thickness tester is also permitted under this specification. For nondestructive testing, this is the preferred method. Make sufficient readings to ensure that the minimum thickness has been determined.

8.4.2.1 *Pipe Wall*—Measure the wall thickness, in the waterway, in the gaps between the profile or other bracing shapes.

8.4.2.2 *Spigot and Bell*—Measure the wall at any point along the bell and spigot, except at the bell entrance taper or contour.

8.5 Ring Stiffness Constant (RSC):

8.5.1 *Qualification Testing*—Determine the RSC by dividing the parallel plate load, in pounds per foot of pipe, by the resulting deflection, in percent, at 3 % deflection. The test shall be conducted in accordance with Test Method D2412, except that the rate of loading shall be 2 in./min and the length of the test pieces shall be as follows:

8.5.1.1 Test three specimens, each squarely cut from a pipe section. For pipe sizes up to 48-in. diameter, the test specimen shall have a length of two pipe diameters or 4 ft (1.22 m), whichever is less. For sizes larger than 48-in. diameter, the length of the test specimen shall be one pipe diameter or 6 ft (1.83 m), whichever is less. The RSC of each of the three specimens shall equal or exceed the minimum values in Table 3.

8.5.2 *Quality Control Testing*—For purposes of quality control, RSC testing of full lengths of pipe is permitted under this specification, provided a statistical correlation has been established between the full length testing and testing of short pieces as detailed in 8.5.1. The testing procedure shall be in accordance with Test Method D2412, with the exceptions that the rate of loading shall be 2 in./min, the conditioning and test temperature shall be in accordance with 8.1.2, and the parallel plate load shall be applied at any location along the pipe's length but not closer than 1.5 diameters from either of its ends in sizes up to 48-in. diameter and 6 ft (2.13 m) from either of its ends in larger sizes. The RSC values thus obtained must always meet or exceed the values established for full length testing that correspond with the Table 3 values obtained on short-test specimens. In case of disagreement, referee tests shall be conducted in accordance with 8.1.1 and 8.5.1.

NOTE 6—The 3 % deflection criteria, which was selected for testing convenience, should not be interpreted as a product limitation with respect to in-use deflection. The engineer is responsible for establishing the acceptable deflection limit based on pipe material properties and job design considerations.

NOTE 7—The value of the parallel plate load/deflection ratio obtained by this test is significantly higher than the RSC value obtained in