

INTERNATIONAL STANDARD

ISO 4379

Second edition
1993-04-15

Corrected and reprinted
1995-07-15

Plain bearings — Copper alloy bushes

Paliers lisses — Bagues en alliages de cuivre

iTeh STANDARD PREVIEW
(standards.iteh.ai)

[ISO 4379:1993](https://standards.iteh.ai/catalog/standards/sist/9ff2f73d-b331-46bc-927c-f29a44703a79/iso-4379-1993)

<https://standards.iteh.ai/catalog/standards/sist/9ff2f73d-b331-46bc-927c-f29a44703a79/iso-4379-1993>



Reference number
ISO 4379:1993(E)

Foreword

ISO (the International Organization for Standardization) is a worldwide federation of national standards bodies (ISO member bodies). The work of preparing International Standards is normally carried out through ISO technical committees. Each member body interested in a subject for which a technical committee has been established has the right to be represented on that committee. International organizations, governmental and non-governmental, in liaison with ISO, also take part in the work. ISO collaborates closely with the International Electrotechnical Commission (IEC) on all matters of electrotechnical standardization.

Draft International Standards adopted by the technical committees are circulated to the member bodies for voting. Publication as an International Standard requires approval by at least 75 % of the member bodies casting a vote.

International Standard ISO 4379 was prepared by Technical Committee ISO/TC 123, *Plain bearings*, Sub-Committee SC 3, *Dimensions, tolerances and construction details*.

<https://standards.iteh.ai/catalog/standards/sist/9ff2f73d-b331-46bc-927c-19314765279/iso-4379-1993>

This second edition cancels and replaces the first edition (ISO 4379:1978), which has been technically revised.

Annex A of this International Standard is for information only.

© ISO 1993

All rights reserved. No part of this publication may be reproduced or utilized in any form or by any means, electronic or mechanical, including photocopying and microfilm, without permission in writing from the publisher.

International Organization for Standardization
Case Postale 56 • CH-1211 Genève 20 • Switzerland

Printed in Switzerland

Plain bearings — Copper alloy bushes

1 Scope

This International Standard specifies dimensions and tolerances for cylindrical and flanged bushes with internal diameter, d_1 , in the range 6 mm to 200 mm.

It applies to solid mono-metal copper alloy bushes to be used as plain bearings with and without oil holes and oil grooves.

2 Normative references

The following standards contain provisions which, through reference in this text, constitute provisions of this International Standard. At the time of publication, the editions indicated were valid. All standards are subject to revision, and parties to agreements based on this International Standard are encouraged to investigate the possibility of applying the most recent editions of the standards indicated below. Members of IEC and ISO maintain registers of currently valid International Standards.

ISO 1302:1992, *Technical drawings — Method of indicating surface texture*.

ISO 2768-1:1989, *General tolerances — Part 1: Tolerances for linear and angular dimensions without individual tolerance indications*.

ISO 4382-1:1991, *Plain bearings — Copper alloys — Part 1: Cast copper alloys for solid and multilayer thick-walled plain bearings*.

ISO 4382-2:1991, *Plain bearings — Copper alloys — Part 2: Wrought copper alloys for solid plain bearings*.

ISO 12301:1992, *Plain bearings — Quality control techniques and inspection of geometrical and material quality characteristics*.

3 Dimensions and tolerances

Dimensions shall be as shown and given in figure 1 and in tables 1 and 2.

Tolerances shall be as given in table 3.

Tolerance classes which deviate from those given in this International Standard shall in each case be added in the designation to the nominal size.

The dimensions of d_2 shall be used to determine the IT value in the case of the coaxial tolerance.

The dimensions of d_3 shall be used to determine the IT value in the case of the axial runout.

Details which have not been specified shall be chosen appropriately.

All dimensions are given in millimetres.

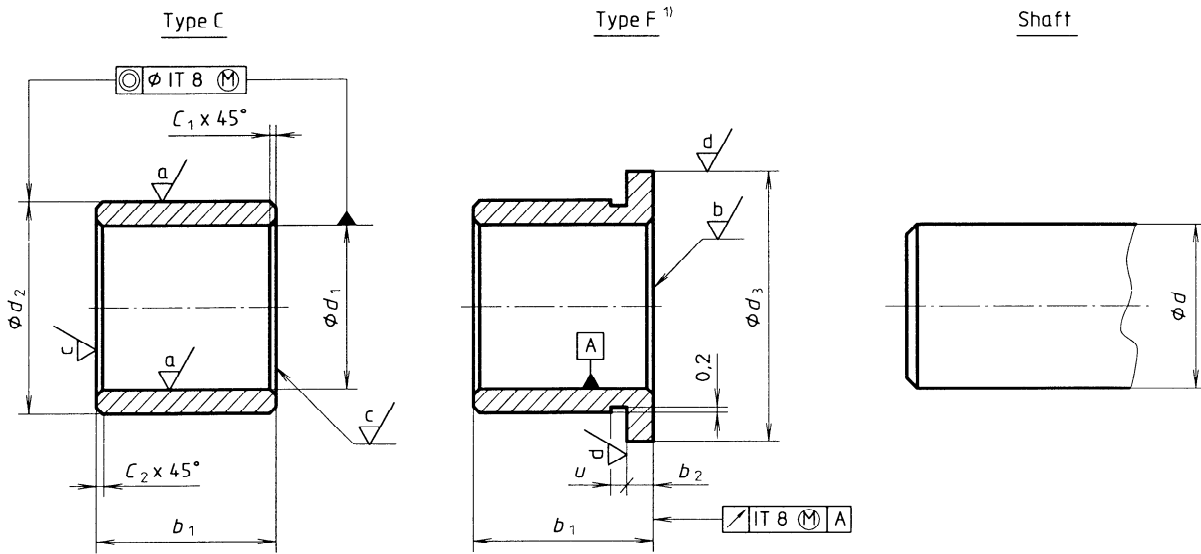

1) Other dimensions and details as type C.

Figure 1

iTeh STANDARD PREVIEW
(standard.itteh.ai)

Table 1 — Type C

d_1				ISO 4379:1993 https://standards.itteh.ai/catalog/standards/sist/9ff2f73d-b331-46bc-927c-f29a44703a79/iso-4379-1993			Chamfers	
							C_1, C_2 max.	C_2 max.
6	8	10	12	6	10	—	0,3	1
8	10	12	14	6	10	—	0,3	1
10	12	14	16	6	10	—	0,3	1
12	14	16	18	10	15	20	0,5	2
14	16	18	20	10	15	20	0,5	2
15	17	19	21	10	15	20	0,5	2
16	18	20	22	12	15	20	0,5	2
18	20	22	24	12	20	30	0,5	2
20	23	24	26	15	20	30	0,5	2
22	25	26	28	15	20	30	0,5	2
(24)	27	28	30	15	20	30	0,5	2
25	28	30	32	20	30	40	0,5	2
(27)	30	32	34	20	30	40	0,5	2
28	32	34	36	20	30	40	0,5	2
30	34	36	38	20	30	40	0,5	2

d_1	d_2			b_1			Chamfers	
							45° C_1, C_2 max.	15° C_2 max.
32	36	38	40	20	30	40	0,8	3
(33)	37	40	42	20	30	40	0,8	3
35	39	41	45	30	40	50	0,8	3
(36)	40	42	46	30	40	50	0,8	3
38	42	45	48	30	40	50	0,8	3
40	44	48	50	30	40	60	0,8	3
42	46	50	52	30	40	60	0,8	3
45	50	53	55	30	40	60	0,8	3
48	53	56	58	40	50	60	0,8	3
50	55	58	60	40	50	60	0,8	3
55	60	63	65	40	50	70	0,8	3
60	65	70	75	40	60	80	0,8	3
65	70	75	80	50	60	80	1	4
70	75	80	85	50	70	90	1	4
75	80	85	90	50	70	90	1	4
80	85	90	95	60	80	100	1	4
85	90	95	100	60	80	100	1	4
90	100	105	110	60	80	120	1	4
95	105	110	115	60	100	120	1	4
100	110	115	120	80	100	120	1	4
105	115	120	125	80	100	120	1	4
110	120	125	130	80	100	120	1	4
120	130	135	140	100	120	150	1	4
130	140	145	150	100	120	150	2	5
140	150	155	160	100	150	180	2	5
150	160	165	170	120	150	180	2	5

d_1	d_2			b_1			Chamfers	
							45° C_1, C_2 max.	15° C_2 max.
160	170	180	185	120	150	180	2	5
170	180	190	195	120	180	200	2	5
180	190	200	210	150	180	250	2	5
190	200	210	220	150	180	250	2	5
200	210	220	230	180	200	250	2	5

NOTE — Values in parentheses are for special applications only. They shall be avoided as far as possible.

Table 2 — Type F

d_1	d_2	d_3 Series 1	b_2	d_2	d_3 Series 2	b_2	b_1			Chamfers		u
										45° C_1, C_2 max.	15° C_2 max.	
6	8	10	1	12	14	3	—	10	—	0,3	1	1
8	10	12	1	14	18	3	—	10	—	0,3	1	1
10	12	14	1	16	20	3	—	10	—	0,3	1	1
12	14	16	1	18	22	3	10	15	20	0,5	2	1
14	16	18	1	20	25	3	10	15	20	0,5	2	1
15	17	19	1	21	27	3	10	15	20	0,5	2	1
16	18	20	1	22	28	3	12	15	20	0,5	2	1,5
18	20	22	1	24	30	3	12	20	30	0,5	2	1,5
20	23	26	1,5	26	32	3	15	20	30	0,5	2	1,5
22	25	28	1,5	28	34	3	15	20	30	0,5	2	1,5
(24)	27	30	1,5	30	36	3	15	20	30	0,5	2	1,5
25	28	31	1,5	32	38	4	20	30	40	0,5	2	1,5
(27)	30	33	1,5	34	40	4	20	30	40	0,5	2	1,5
28	32	36	2	36	42	4	20	30	40	0,5	2	1,5
30	34	38	2	38	44	4	20	30	40	0,5	2	2
32	36	40	2	40	46	4	20	30	40	0,8	3	2
(33)	37	41	2	42	48	5	20	30	40	0,8	3	2
35	39	43	2	45	50	5	30	40	50	0,8	3	2
(36)	40	44	2	46	52	5	30	40	50	0,8	3	2
38	42	46	2	48	54	5	30	40	50	0,8	3	2

d_1	d_2	d_3 Series 1	b_2	d_2	d_3 Series 2	b_2	b_1			Chamfers		u
										45° C_1, C_2 max.	15° C_2 max.	
40	44	48	2	50	58	5	30	40	60	0,8	3	2
42	46	50	2	52	60	5	30	40	60	0,8	3	2
45	50	55	2,5	55	63	5	30	40	60	0,8	3	2
48	53	58	2,5	58	66	5	40	50	60	0,8	3	2
50	55	60	2,5	60	68	5	40	50	60	0,8	3	2
55	60	65	2,5	65	73	5	40	50	70	0,8	3	2
60	65	70	2,5	75	83	7,5	40	60	80	0,8	3	2
65	70	75	2,5	80	88	7,5	50	60	80	1	4	2
70	75	80	2,5	85	95	7,5	50	70	90	1	4	2
75	80	85	2,5	90	100	7,5	50	70	90	1	4	3
80	85	90	2,5	95	105	7,5	60	80	100	1	4	3
85	90	95	2,5	100	110	7,5	60	80	100	1	4	3
90	100	110	5	110	120	10	60	80	120	1	4	3
95	105	115	5	115	125	10	60	100	120	1	4	3
100	110	120	5	120	130	10	80	100	120	1	4	3
105	115	125	5	125	135	10	80	100	120	1	4	3
110	120	130	5	130	140	10	80	100	120	1	4	3
120	130	140	5	140	150	10	100	120	150	1	4	3
130	140	150	5	150	160	10	100	120	150	2	5	4
140	150	160	5	160	170	10	100	150	180	2	5	4
150	160	170	5	170	180	10	120	150	180	2	5	4
160	170	180	5	185	200	12,5	120	150	180	2	5	4
170	180	190	5	195	210	12,5	120	180	200	2	5	4
180	190	200	5	210	220	15	150	180	250	2	5	4
190	200	210	5	220	230	15	150	180	250	2	5	4
200	210	220	5	230	240	15	180	200	250	2	5	4

NOTE — Values in parentheses are for special applications only. They shall be avoided as far as possible.

Table 3 — Tolerances

d_1	d_2		d_3	b_1	Housing bore	Shaft diameter d
E6*)	≤ 120	s6	d11	h13	H7	e7 or g7**)
	> 120	r6				

*) After pressing, this usually gives a tolerance position H and tolerance grade approximately IT8.

**) Recommended tolerance, depending on application.

When the bushes are to be used in conjunction with ready-made precision ground shafts of tolerance position h, the tolerance on the inside diameter d_1 shall be D6, so that the probable tolerance after fitting is F8.

If the bearing bore is to be machined after fitting, the size and tolerance of the inside diameter d_1 shall be agreed upon between the manufacturer and customer.

4 Material

Cast copper alloys shall be in accordance with ISO 4382-1.

Wrought copper alloys shall be in accordance with ISO 4382-2.





For outside chamfer C_2 of 15°, Y shall be additionally specified in the designation.

Other chamfers shall be agreed between the manufacturer and customer.

Flange bushes type F with or without undercut (dimension u) shall be agreed between the manufacturer and customer.

5 Surface finish

Surface roughness, indicated according to ISO 1302 (see figure 1), shall be the following:

-  : $R_a \leq 1,6 \mu\text{m}$
-  : $R_a \leq 3,2 \mu\text{m}$
-  : $R_a \leq 6,3 \mu\text{m}$
-  : $R_a \leq 25 \mu\text{m}$

Edges shall be free of burrs.

Slight indentations shall only be accepted on the outside surfaces and provided they are considered not to have an effect on fitting and function.

NOTE 1 The tolerance classes recommended in this International Standard are applicable to any normal applications in general machinery construction. The fits recommended in this International Standard should be checked in the case of bushes used in the area of hydrodynamic lubrication, or pressed or bonded in housings which are unusual as regards both material and design.

7 Quality assurance

For quality control techniques and inspection of the geometrical and material quality characteristics, see ISO 12301.

6 Construction

Permissible deviations for dimensions without tolerance indication shall be in accordance with tolerance class "m" specified in ISO 2768-1.

For outside chamfer C_2 of 45°, no special designation details are required.

8 Designation

EXAMPLE

Designation of a bush type C of inside diameter $d_1 = 20$ mm, outside diameter $d_2 = 24$ mm and width $b_1 = 20$ mm, with agreed outside chamfer C_2 of 15° (Y), made of CuSn8P in accordance with ISO 4382-2:

Bush ISO 4379 - C 20 × 24 × 20 Y - CuSn8P

iTech STANDARD PREVIEW
(standards.itech.ai)

Annex A
(informative)

Bibliography

- [1] ISO 468:1982, *Surface roughness — Parameters, their values and general rules for specifying requirements*.
- [2] ISO 2692:1988, *Technical drawings — Geometrical tolerancing — Maximum material principle*.

iTeh STANDARD PREVIEW
(standards.iteh.ai)

[ISO 4379:1993](https://standards.iteh.ai/catalog/standards/sist/9ff2f73d-b331-46bc-927c-f29a44703a79/iso-4379-1993)

<https://standards.iteh.ai/catalog/standards/sist/9ff2f73d-b331-46bc-927c-f29a44703a79/iso-4379-1993>