



Designation: D6115 – 97 (Reapproved 2019)

# Standard Test Method for Mode I Fatigue Delamination Growth Onset of Unidirectional Fiber-Reinforced Polymer Matrix Composites<sup>1</sup>

This standard is issued under the fixed designation D6115; the number immediately following the designation indicates the year of original adoption or, in the case of revision, the year of last revision. A number in parentheses indicates the year of last reapproval. A superscript epsilon ( $\epsilon$ ) indicates an editorial change since the last revision or reapproval.

## 1. Scope

1.1 This test method determines the number of cycles ( $N$ ) for the onset of delamination growth based on the opening mode I cyclic strain energy release rate ( $G$ ), using the Double Cantilever Beam (DCB) specimen shown in Fig. 1. This test method applies to constant amplitude, tension-tension fatigue loading of continuous fiber-reinforced composite materials. When this test method is applied to multiple specimens at various  $G$ -levels, the results may be shown as a  $G$ - $N$  curve, as illustrated in Fig. 2.

1.2 This test method is limited to use with composites consisting of unidirectional carbon fiber tape laminates with single-phase polymer matrices. This limited scope reflects the experience gained in round robin testing. This test method may prove useful for other types and classes of composite materials, however, certain interferences have been noted (see Section 6.5 of Test Method D5528).

1.3 The values stated in SI units are to be regarded as standard. No other units of measurement are included in this standard.

1.3.1 *Exception*—The values provided in parentheses are for information only.

1.4 *This standard does not purport to address all of the safety concerns, if any, associated with its use. It is the responsibility of the user of this standard to establish appropriate safety, health, and environmental practices and determine the applicability of regulatory limitations prior to use.*

1.5 *This international standard was developed in accordance with internationally recognized principles on standardization established in the Decision on Principles for the Development of International Standards, Guides and Recommendations issued by the World Trade Organization Technical Barriers to Trade (TBT) Committee.*

<sup>1</sup> This test method is under the jurisdiction of ASTM Committee D30 on Composite Materials and is the direct responsibility of Subcommittee D30.06 on Interlaminar Properties.

Current edition approved March 15, 2019. Published March 2019. Originally approved in 1997. Last previous edition approved in 2011 as D6115 – 97(2011). DOI: 10.1520/D6115-97R19.

## 2. Referenced Documents

### 2.1 ASTM Standards:<sup>2</sup>

- D883 Terminology Relating to Plastics
- D2584 Test Method for Ignition Loss of Cured Reinforced Resins
- D2651 Guide for Preparation of Metal Surfaces for Adhesive Bonding
- D2734 Test Methods for Void Content of Reinforced Plastics
- D3171 Test Methods for Constituent Content of Composite Materials
- D3878 Terminology for Composite Materials
- D5229/D5229M Test Method for Moisture Absorption Properties and Equilibrium Conditioning of Polymer Matrix Composite Materials
- D5528 Test Method for Mode I Interlaminar Fracture Toughness of Unidirectional Fiber-Reinforced Polymer Matrix Composites
- E4 Practices for Force Verification of Testing Machines
- E6 Terminology Relating to Methods of Mechanical Testing
- E122 Practice for Calculating Sample Size to Estimate, With Specified Precision, the Average for a Characteristic of a Lot or Process
- E177 Practice for Use of the Terms Precision and Bias in ASTM Test Methods
- E456 Terminology Relating to Quality and Statistics
- E467 Practice for Verification of Constant Amplitude Dynamic Forces in an Axial Fatigue Testing System
- E691 Practice for Conducting an Interlaboratory Study to Determine the Precision of a Test Method
- E739 Practice for Statistical Analysis of Linear or Linearized Stress-Life ( $S$ - $N$ ) and Strain-Life ( $\epsilon$ - $N$ ) Fatigue Data
- E1049 Practices for Cycle Counting in Fatigue Analysis
- E1150 Definitions of Terms Relating to Fatigue (Withdrawn 1996)<sup>3</sup>

<sup>2</sup> For referenced ASTM standards, visit the ASTM website, www.astm.org, or contact ASTM Customer Service at service@astm.org. For *Annual Book of ASTM Standards* volume information, refer to the standard's Document Summary page on the ASTM website.

<sup>3</sup> The last approved version of this historical standard is referenced on www.astm.org.

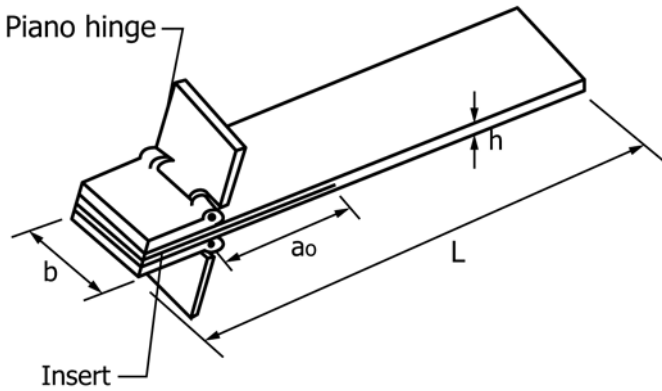

FIG. 1 DCB Specimen with Piano Hinges

### 3. Terminology

3.1 Terminology D3878 defines terms relating to high-modulus fibers and their composites. Terminology D883 defines terms relating to plastics. Terminology E6 defines terms relating to mechanical testing. Terminology E456 and Practice E177 define terms relating to statistics. Definitions E1150 defines terms relating to fatigue. In the event of conflict between terms, Terminology D3878 shall have precedence over the other terminology standards.

#### 3.2 Definitions of Terms Specific to This Standard:

3.2.1 *crack opening mode (Mode I)*—fracture mode in which the delamination faces open away from each other and in which these faces do not undergo any relative sliding.

3.2.2 *cycles to onset of delamination growth,  $N_a$* —the number of fatigue cycles elapsed until the onset of delamination growth from an implanted thin insert.

3.2.3 *fatigue delamination growth onset relationship,  $G-N$* —the relationship between the peak cyclic value of strain energy release rate to the number of fatigue cycles until the onset of delamination growth,  $N_a$ .

3.2.4 *mode I interlaminar fracture toughness,  $G_{Ic}$* —the critical value of  $G$  for delamination growth because of an opening load or displacement.

3.2.5 *strain energy release rate,  $G$* —the loss of strain energy,  $dU$ , in the test specimen per unit of specimen width for an infinitesimal increase in delamination length,  $da$ , for a delamination growing under a constant displacement. In mathematical form:

$$G = -\frac{1}{b} \frac{dU}{da} \quad (1)$$

where:

- $U$  = total elastic strain energy in the test specimen,
- $b$  = specimen width, and
- $a$  = delamination length.

#### 3.3 Symbols:

- 3.3.1  $a$ —delamination length.
- 3.3.2  $a_0$ —initial delamination length.
- 3.3.3  $b$ —width of DCB specimen.
- 3.3.4  $C$ —compliance,  $\delta/P$ , of DCB specimen.

3.3.5  $CV$ —coefficient of variation, %.

3.3.6  $da$ —infinitesimal increase in delamination length.

3.3.7  $dU$ —infinitesimal increase in strain energy.

3.3.8  $E_{II}$ —modulus of elasticity in the fiber direction.

3.3.9  $G$ —strain energy release rate.

3.3.10  $G_{Ic}$ —opening mode I interlaminar fracture toughness.

3.3.11  $[G_{Ic}]_{av}$ —average values of  $G_{Ic}$  from the quasi-static tests.

3.3.12  $G_{I_{max}}$ —maximum or peak cyclic mode I strain energy release rate.

3.3.13  $G-N$ —relationship between the cyclic strain energy release rate and the number of cycles to onset of delamination growth.

3.3.14  $h$ —thickness of DCB specimen.

3.3.15  $N$ —number of elapsed fatigue cycles.

3.3.16  $N_a$ —application dependent value of  $N$  at which delamination growth onset will occur.

3.3.17  $N_a^1$ —number of fatigue cycles for the value of  $P_{max}$  at  $N = 1$  to decrease by 1 %.

3.3.18  $N_a^{vis}$ —number of fatigue cycles at which the onset of delamination growth is observed.

3.3.19  $N_a^5$ —number of fatigue cycles for the value of  $P_{max}$  at  $N = 1$  to decrease by 5 %.

3.3.20  $P$ —applied load.

3.3.21  $P_{cr}$ —value of load at the onset of delamination growth from the insert in the quasi-static tests.

3.3.22  $P_{max}$ —maximum cyclic load.

3.3.23  $R$ —ratio of minimum and peak loads  $P_{min}/P_{max}$ .

3.3.24  $SD$ —standard deviation.

3.3.25  $U$ —strain energy.

3.3.26  $V_f$ —fiber volume fraction, %.

3.3.27  $\delta$ —load point deflection.

3.3.28  $\delta_{cr}$ —value of displacement at the onset of delamination growth from the insert in a quasi-static test.

3.3.29  $\delta_{max}$ —maximum value of cyclic displacement.

3.3.30  $\delta_{mean}$ —mean value of cyclic displacement.

3.3.31  $\delta_{min}$ —minimum value of cyclic displacement.

3.3.32  $\Delta$ —effective delamination extension to correct for rotation of DCB arms at delamination front.

3.3.33  $[\Delta]_{av}$ —average value of  $\Delta$  from the quasi-static tests.

### 4. Summary of Test Method

4.1 The Double Cantilever Beam (DCB) shown in Fig. 2 is described in Test Method D5528.

4.2 The DCB specimen is cycled between a minimum and maximum displacement,  $\delta_{min}$  and  $\delta_{max}$ , at a specified frequency. For linear elasticity and small deflections ( $\delta/a < 0.4$ ) the displacement ratio,  $\delta_{min} / \delta_{max}$ , is identical to the  $R$ -ratio. The number of displacement cycles at which the onset of delamination growth occurs,  $N_a$ , is recorded. The mode I cyclic strain energy release rate, for example the maximum value,

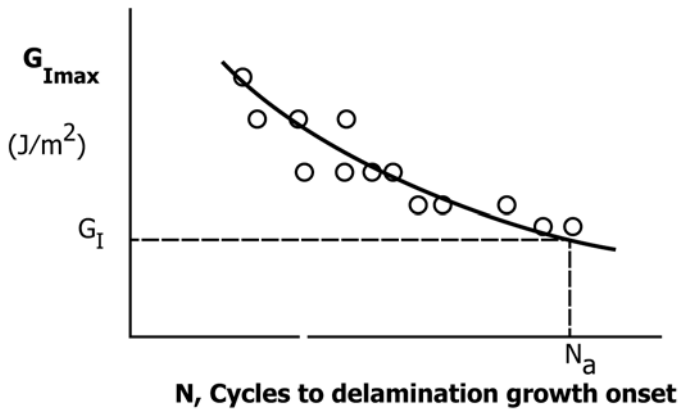

FIG. 2 G–N Curve

$G_{I_{max}}$  is calculated using a modified beam theory or other methods described in Test Method D5528. By testing several specimens a relationship is developed between  $G_{I_{max}}$  and  $N_a$  for the chosen frequency.

## 5. Significance and Use

5.1 Susceptibility to delamination is one of the major weaknesses of many advanced laminated composite structures. Knowledge of a laminated composite material's resistance to interlaminar fracture under fatigue loads is useful for product development and material selection. Furthermore, a measurement of the relationship of the mode I cyclic strain energy release rate and the number of cycles to delamination growth onset,  $G-N$ , that is independent of specimen geometry or method of load introduction, is useful for establishing design allowables used in damage tolerance analyses of composite structures made from these materials.

5.2 This test method can serve the following purposes:

5.2.1 To establish quantitatively the effects of fiber surface treatment, local variations in fiber volume fraction, and processing and environmental variables on  $G-N$  of a particular composite material.

5.2.2 To compare quantitatively the relative values of  $G-N$  for composite materials with different constituents.

5.2.3 To develop criteria for avoiding the onset of delamination growth under fatigue loading for composite damage tolerance and durability analyses.

## 6. Interferences

6.1 Linear elastic behavior is assumed in the calculation of  $G$  used in this test method. This assumption is valid when the zone of damage or non-linear deformation at the delamination front, or both, is small relative to the smallest specimen dimension, which is typically the specimen thickness for the DCB test.

6.2 As the delamination grows under fatigue, fiber bridging observed in quasi-static testing (see Test Method D5528) may also occur. Fiber bridging inhibits the fatigue delamination growth resulting in slower growth rates than if there was no bridging. This results in artificially high threshold values where

the delamination ceases to grow or grows very slowly.<sup>4</sup> In addition, the rate of change of the delamination growth rate versus the peak cyclic strain energy release rate for the DCB is very high. Therefore, small variations in the peak cyclic strain energy release rate will result in large changes in the delamination growth rate. For these two reasons, this test method does not monitor the fatigue delamination growth rate. Instead, this test method monitors the number of cycles until the onset of delamination growth from the end of a thin insert. A value of  $G$  may be defined such that delamination growth will not occur until  $N_a$  cycles have elapsed, where  $N_a$  is defined by the application, Fig. 1.

6.3 Three definitions to determine the number of cycles until the onset of delamination growth were used during an investigative round robin. These include: (1) the number of cycles until the delamination was visually observed to grow at the edge,  $N_a^{vis}$ ; (2) the number of cycles until the compliance had increased by 1 %,  $N_a^{1\%}$  (this is approximately equivalent to a 1 % decrease in the maximum cyclic load); and (3) the number of cycles until the compliance has increased by 5 %,  $N_a^{5\%}$  (this is approximately equivalent to a 5 % decrease in the maximum cyclic load). The three techniques gave different results, but the  $N_a^{1\%}$  value is typically the lowest of the three values<sup>5</sup> and is recommended for generating a conservative criterion for avoiding onset of fatigue delamination growth in durability and damage tolerance analyses of laminated composite structures. Because of the difficulties in visually monitoring the end of a delamination during a fatigue test, the visual method is not included in this test method.

6.4 The test frequency may affect results. If the test frequency is high, heating effects may occur in the composite. To avoid these effects, frequency should be chosen to be between 1 and 10 cycles per second (Hz) and should be chosen such that there is no temperature change of the specimen. Other test frequencies may be used if they are more appropriate for the application. The test frequency shall be reported.

6.5 The displacement ratio,  $\delta_{min} / \delta_{max}$ , may have a large effect on the results. Because the DCB specimen cannot be tested in compression the displacement ratio must remain within the following range:  $0 \leq \delta_{min} / \delta_{max} < 1$ . The displacement ratio shall be reported. Large deflections may be considered by using the corrections given in the Annex of Test Method D5528.

6.6 The application to other materials, lay-ups, and architectures is described in Test Method D5528.

## 7. Apparatus

7.1 *Testing Machine*—A properly calibrated test machine shall be used that can be operated in a displacement control mode. The testing machine shall conform to the requirements of Practices E4 and E467. The testing machine shall be

<sup>4</sup> Martin, R. H., and Murri, G. B., "Characterization of Mode I and Mode II Delamination Growth and Thresholds in AS4/PEEK Composites," *Composite Materials: Testing and Design* (9th Volume), ASTM STP 1059, S. P. Garbo, Ed., 1990, pp. 251–270.

<sup>5</sup> Preliminary data from D30.06 round robin.