



Designation: C198 – 09 (Reapproved 2019)

## Standard Test Method for Cold Bonding Strength of Refractory Mortar<sup>1</sup>

This standard is issued under the fixed designation C198; the number immediately following the designation indicates the year of original adoption or, in the case of revision, the year of last revision. A number in parentheses indicates the year of last reapproval. A superscript epsilon ( $\epsilon$ ) indicates an editorial change since the last revision or reapproval.

### 1. Scope

1.1 This test method covers the determination of the bonding strength of air-setting refractory mortar by determining the flexural strength (modulus of rupture) at room temperature of oven-dried brick-mortar joints.

1.2 The values stated in inch-pound units are to be regarded as standard. The values given in parentheses are mathematical conversions to SI units that are provided for information only and are not considered standard.

1.3 *This standard does not purport to address all of the safety concerns, if any, associated with its use. It is the responsibility of the user of this standard to establish appropriate safety, health, and environmental practices and determine the applicability of regulatory limitations prior to use.*

1.4 *This international standard was developed in accordance with internationally recognized principles on standardization established in the Decision on Principles for the Development of International Standards, Guides and Recommendations issued by the World Trade Organization Technical Barriers to Trade (TBT) Committee.*

### 2. Referenced Documents

- 2.1 *ASTM Standards:*<sup>2</sup>
- [C78/C78M Test Method for Flexural Strength of Concrete \(Using Simple Beam with Third-Point Loading\)](#)
  - [C133 Test Methods for Cold Crushing Strength and Modulus of Rupture of Refractories](#)
  - [C651 Test Method for Flexural Strength of Manufactured Carbon and Graphite Articles Using Four-Point Loading at Room Temperature](#)
  - [E4 Practices for Force Verification of Testing Machines](#)
  - [E177 Practice for Use of the Terms Precision and Bias in ASTM Test Methods](#)
  - [E691 Practice for Conducting an Interlaboratory Study to](#)

<sup>1</sup> This test method is under the jurisdiction of ASTM Committee C08 on Refractories and is the direct responsibility of Subcommittee C08.01 on Strength. Current edition approved April 1, 2019. Published April 2019. Originally approved in 1945. Last previous edition approved in 2013 as C198 – 09 (2013). DOI: 10.1520/C0198-09R19.

<sup>2</sup> For referenced ASTM standards, visit the ASTM website, [www.astm.org](http://www.astm.org), or contact ASTM Customer Service at [service@astm.org](mailto:service@astm.org). For *Annual Book of ASTM Standards* volume information, refer to the standard's Document Summary page on the ASTM website.

### Determine the Precision of a Test Method

### 3. Significance and Use

3.1 The data developed by this test method show the bonding strength and intrinsic strength of different qualities of air-setting mortar. The procedures described in this test method measure the bonding strength and intrinsic strength of air-setting mortars when used with specific brands or lots of refractory brick.

3.2 Note that it is possible to obtain results with these methods for brick and mortar combinations which are incompatible for use at high operating temperatures. The user must determine this compatibility. Only brick and mortar combinations known or intended to be compatible for a particular use should be tested.

3.3 Properties of the brick, including its strength, apparent porosity, and pore size distribution, can affect the measurement of both the bonding strength of the brick-mortar composite and the intrinsic strength of the mortar. The average modulus of rupture of the test brick, as determined by Test Methods C133, should exceed that expected for the mortar being tested. The testing of specific brands or lots of brick and mortar is preferred.

3.4 Three modes of failure are available: the break may occur within the brick itself, at the brick-mortar interface, or within the mortar itself. The latter provides a practical measurement of the strength of the mortar itself and is the predominant mode of failure with the four-point flexure test described. The three-point flexure test measures the failure strength of the brick-mortar composite. Failure within the brick itself suggests that either the particular brick contained a serious flaw, or that the mortar joint strength is of the same magnitude or greater than that of the refractory brick. The mode of failure should always be reported in the final report.

3.5 A ruggedness test for this test method<sup>3</sup> performed in 1985 found the following variables to be rugged: specimen size (2.5 to 3.0 in.), mortared surface (cut versus uncut), joint thickness ( $1/16$  to  $1/8$  in.), pulling of rods (fast versus slow), the

<sup>3</sup> Supporting data have been filed at ASTM International Headquarters and may be obtained by requesting Research Report RR:C08-1008. Contact ASTM Customer Service at [service@astm.org](mailto:service@astm.org).

loading rate (500 to 1000 lbf/min), the method of load application (three- versus four-point), and the operator.

3.6 The cold bonding strengths of refractory mortars obtained by this test method are suitable for use in research and development, quality control, and for establishing and evaluating compliance with specifications between producers and consumers.

#### 4. Apparatus

4.1 *Brick*—At least five 9 by 4¼ by 2½-in. (230 by 114 by 65-mm) straight brick having plane surfaces and true rectangular shape and an average modulus of rupture higher than that expected from the mortar under test, when determined in accordance with Test Methods C133, compose a sample.

4.2 *Spacing Rods*—Two joint-thickness spacing rods made of ¼-in. (2-mm) diameter drill rod cut into 4-in. (102-mm) lengths.

4.3 *Oven*—A drying oven to accommodate at least five 9-in. (230-mm) straight brick standing on end, and for use at 220 to 230 °F (105 to 110 °C).

4.4 *Testing Machine*—A standard mechanical or hydraulic compression testing machine conforming to the requirements of Practices E4 and having a sensitivity of 20 lbf or less in the range from 0 to 4000 lbf (17.8 kN) may be used.

4.5 *Loading Fixture*—The fixtures shall provide load bearing blocks which ensure that the forces are applied normal to the beam without eccentricity. The directions of loads and reactions may be maintained parallel by judicious use of linkages, roller bearings, and flexure plates. Eccentricity of loading can be avoided by the use of spherical bearings.

4.5.1 Test Methods C133 provide illustrations of three-point loading fixtures which meet the above requirements. One acceptable four-point loading fixture is illustrated in Test

Method C78/C78M. Another is illustrated in Test Method C651. The span length,  $L$ , of the support blocks shall be  $7.00 \pm 0.05$  in. ( $178 \pm 1$  mm). The span length,  $l$ , of the load-applying blocks for four-point loading shall be  $2.33 \pm 0.05$  in. ( $59 \pm 1$  mm) (see Figs. 1 and 2).

#### 5. Sampling

5.1 *Wet Mortars*—The sample of mortar shall be a prepared test sample of about 10 lb (4.5 kg) (approximately ½ gal (1.89 L)). If the weight of the commercial container is appreciably more than 10 lb, the contents of the container shall be thoroughly mixed in the container, or transferred without loss to a clean impervious receptacle of larger size and mixed thoroughly to a uniform consistency. A 10-lb test sample shall then be taken and placed in a suitable covered container resistant to the possible corrosive action of the mortar.

5.2 *Dry Mortars*—The sample of mortar submitted shall be a prepared test sample of 10 lb (4.5 kg) or a larger quantity, such as a 50 or 100-lb (23 or 45-kg) bag from which a 10-lb (4.5 kg) sample may be obtained using acceptable sampling procedures. The 10-lb (4.5 kg) sample should be thoroughly mixed with water to a uniform troweling consistency and stored in a covered container (resistant to possible corrosive action by the mortar) for at least 16 h prior to the test.

NOTE 1—Reaction of phosphoric acid or aluminum phosphate with metallics may cause the development of hydrogen gas in some mortars. Therefore, the container should be covered only to minimize moisture loss, not tightly sealed.

#### 6. Procedure

6.1 Cut each of the bricks of the sample (see Note 2) into two equal parts on a plane parallel to the 2½ by 4¼-in. (65 by 114-mm) face. Use the uncut 2½ by 4¼-in. face of each dry half-brick to form the mortar joint. The test mortar shall be of

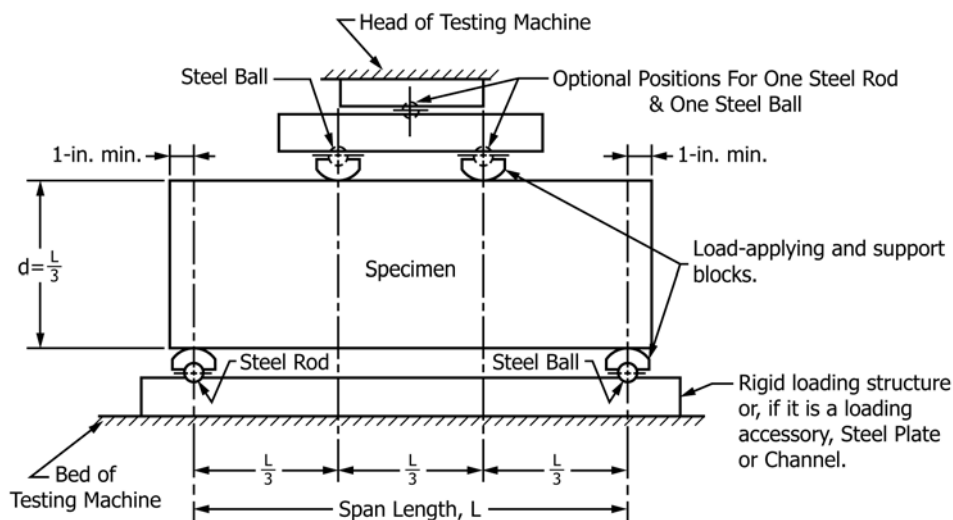

NOTE 1—This apparatus may be used inverted. If the testing machine applies a force through a spherically sealed head, the center pivot may be omitted, provided one load-applying block pivots on a rod and the other on a ball.

NOTE 2—1 in. = 25.4 mm.

FIG. 1 Diagrammatic View of a Suitable Apparatus for Flexure Test of Refractory Mortar Joints, Four-Point Loading Method