



Standard Specification for Door Fittings, for Watertight /Gastight /Airtight, Weathertight, and Non-Tight Doors, for Marine Use¹

This standard is issued under the fixed designation F1073; the number immediately following the designation indicates the year of original adoption or, in the case of revision, the year of last revision. A number in parentheses indicates the year of last reapproval. A superscript epsilon (ϵ) indicates an editorial change since the last revision or reapproval.

1. Scope

1.1 This specification covers the principal design and type of material for manufacturing fittings for watertight/gastight/airtight, weathertight, and non-tight doors, for marine use. Note that “gastight” is commercial terminology which also means “airtight” in naval terminology.

1.2 The values stated in inch-pound units are to be regarded as standard. The values given in parentheses are mathematical conversions to SI units that are provided for information only and are not considered standard.

1.3 The fittings are intended for use on all doors for marine use, except joiner and expanded metal doors.

1.4 *This international standard was developed in accordance with internationally recognized principles on standardization established in the Decision on Principles for the Development of International Standards, Guides and Recommendations issued by the World Trade Organization Technical Barriers to Trade (TBT) Committee.*

2. Referenced Documents

2.1 ASTM Standards:²

- A36/A36M Specification for Carbon Structural Steel
- A240/A240M Specification for Chromium and Chromium-Nickel Stainless Steel Plate, Sheet, and Strip for Pressure Vessels and for General Applications
- A276 Specification for Stainless Steel Bars and Shapes
- A563 Specification for Carbon and Alloy Steel Nuts
- A668/A668M Specification for Steel Forgings, Carbon and Alloy, for General Industrial Use
- B140/B140M Specification for Copper-Zinc-Lead (Red Brass or Hardware Bronze) Rod, Bar, and Shapes

B210 Specification for Aluminum and Aluminum-Alloy Drawn Seamless Tubes (Metric) B0210_B0210M

B211 Specification for Aluminum and Aluminum-Alloy Rolled or Cold-Finished Bar, Rod, and Wire (Metric) B0211_B0211M

2.2 Military Standards:³

- MIL-C-81706 Coating, Aluminum and Aluminum Alloys
- MIL-DRL-24441D
- MIL-DTL-24441/20B(SH) Paint, Epoxy-Polyamide, Green Primer, Formula 150, Type III
- MIL-DTL-24441/21B(SH) Paint, Epoxy-Polyamide, Haze Gray Formula 151, Type III
- MIL-P-17578A Packing Material, Plastic (for Dogs for Watertight Closures) (Symbol 1425)

NAVSEA SI 009-32 Cleaning and Painting Requirements; Accomplish

2.3 Federal Specifications:³

- QQ-C-390B (Notice 2) Copper Alloy Castings (see this notice for ASTM references)
- MIL-PRF-24635 Performance Specification: Coating Systems, Weather-Resistant, Exterior Use

2.4 ANSI Standard:

A2.6 Standard for Fire Tests of Window Assemblies⁴

2.5 AISI Standard:

316 Low Alloy Stainless Steel (Cres 316)⁵

3. Classification

3.1 The dogs and hinges shall be classified as given in **Table 1**.

4. Ordering Information

4.1 Ordering for fittings shall be indicated on the purchase order prepared for doors, with reference to this specification noted.

4.2 When ordering fittings, indicate the following:

¹ This specification is under the jurisdiction of ASTM Committee F25 on Ships and Marine Technology and is the direct responsibility of Subcommittee F25.03 on Outfitting and Deck Machinery.

Current edition approved March 1, 2019. Published April 2019. Originally approved in 1987. Last previous edition approved in 2012 as F1073 – 87 (2012). DOI: 10.1520/F1073-19.

² For referenced ASTM standards, visit the ASTM website, www.astm.org, or contact ASTM Customer Service at service@astm.org. For *Annual Book of ASTM Standards* volume information, refer to the standard's Document Summary page on the ASTM website.

³ Available from Standardization Documents Order Desk, DODSSP, Bldg. 4, Section D, 700 Robbins Ave., Philadelphia, PA 19111-5098, <http://www.dodssp.daps.mil>.

⁴ Available from American National Standards Institute (ANSI), 25 W. 43rd St., 4th Floor, New York, NY 10036, <http://www.ansi.org>.

⁵ Available from American Iron and Steel Institute (AISI), 1140 Connecticut Ave., NW, Suite 705, Washington, DC 20036, <http://www.steel.org>.

TABLE 1 Classification of Dogs and Hinges

Type	Description
<i>Dog:</i>	
A	Fitted to door
B	Fitted to door frame
<i>Hinge:</i>	
A	With clenched pin
B	With clenched pin secured with cotter pin

- 4.2.1 Type,
- 4.2.2 Quantity,
- 4.2.3 Marking (see Section 8), and

4.3 Inspection and acceptance of fittings shall be agreed upon between the purchaser and the supplier.

5. Materials and Manufacture

- 5.1 The material shall be as specified in **Tables 2-4**.
- 5.2 All securing screws and fasteners shall be of stainless steel, Type 316.
- 5.3 All glazing in portlights of fire door shall meet ANSI A2.6.

6. Construction, Shape, and Dimensions

- 6.1 The construction, shape, and dimensions for dogs and hinges shall be as shown in **Figs. 1-9**.
- 6.2 Door dogs shall be supplied with hold-open clips.

7. Workmanship, Finish, and Appearance

- 7.1 All materials shall have a smooth finish.
- 7.2 Pretreatment and priming of door fittings shall be as follows:

7.2.1 Mild steel fittings shall be abrasive blasted to “near white” metal and coated with inorganic zinc silicate at 1.5 to 3.0 mils.

7.2.2 Steel fittings, secured on doors, shall be welded to steel; whereas aluminum fittings when secured to aluminum or glass-reinforced plastic doors, shall be welded or bolted into position.

7.2.3 Nonferrous fittings shall be either riveted or bolted to aluminum, steel or glass-reinforced plastic doors, or combination thereof.

7.2.4 Where different metals are to be used, insulation shall be used between them, in way of contact, to prevent galvanic action.

8. Product Marking

8.1 Each fitting shall be marked with its purchase order number and shall indicate the type of fitting, left hand or right hand. The marking shall be applied on a waterproof tag and attached to the fitting.

9. Keywords

9.1 airtight; door fittings; doors; gastight; marine; non-tight; ship; tightness integrity; watertight; weathertight

ASTM F1073-19

TABLE 2 Material for Door Dogs

Component		Mild Steel	Aluminum	Glass-Reinforced Plastic
Number	Item			
1	Handle interior	Specification A668/A668M	Specification A668/A668M	Specification A668/A668M
2	Handle exterior	Specification A668/A668M	Specification A668/A668M	Specification A668/A668M
3	Jam nut	Specification A563	Specification A563	Specification A276
4	Spring washer	steel commercial	AISI (316)	AISI (316)
5	Washer	steel commercial	steel commercial	steel commercial
6	Dog sleeve	Specification A36/A36M	Specification B210 (AL-5086)	Specification B210 (AL 5086)
7	Bushing	oil impregnated bronze	oil impregnated bronze	oil impregnated bronze
8	Packing	MIL-P-17578A	MIL-P-17578A	MIL-P-17578A
9	Packing gland	MIL-P-17578A	MIL-P-17578A	MIL-P-17578A
10	Grease fitting	Specification B140/B140M	Specification B140/B140M	Specification B140/B140M
11	Wedge	copper alloy casting or commercial steel	Specification B211	copper alloy casting or commercial steel

TABLE 3 Material for Door Hinges

Component		Mild Steel	Aluminum	Glass-Reinforced Plastic
Number	Item			
1	Piece to frame	Specification A36/A36M	Specification A240/A240M	Specification A240/A240M
2	Piece to door	Specification A36/A36M	Specification A240/A240M	Specification A240/A240M
3	Clenched pin	corrosion-resistant steel (316)	corrosion-resistant steel (316)	corrosion-resistant steel (316)
4	Washer	corrosion-resistant steel (commercial)	corrosion-resistant steel (commercial)	corrosion-resistant steel (commercial)
5	Cotter pin	corrosion-resistant steel (commercial)	corrosion-resistant steel (commercial)	corrosion-resistant steel (commercial)

TABLE 4 Material for Miscellaneous Fittings Door Material

Component		Mild Steel	Aluminum	Glass-Reinforced Plastic
Number	Item			
1	Port light	Specification A240/A240M	Specification A240/A240M	Specification A240/A240M
2	Label plate	Specification A240/A240M	Specification A240/A240M	Specification A240/A240M
3	Hasp and eye	Specification A276	Specification A276	Specification A276
4	Hold back hook	Specification A276	Specification A276	Specification A276
5	Grab handle	Specification A276	Specification A276	Specification A276

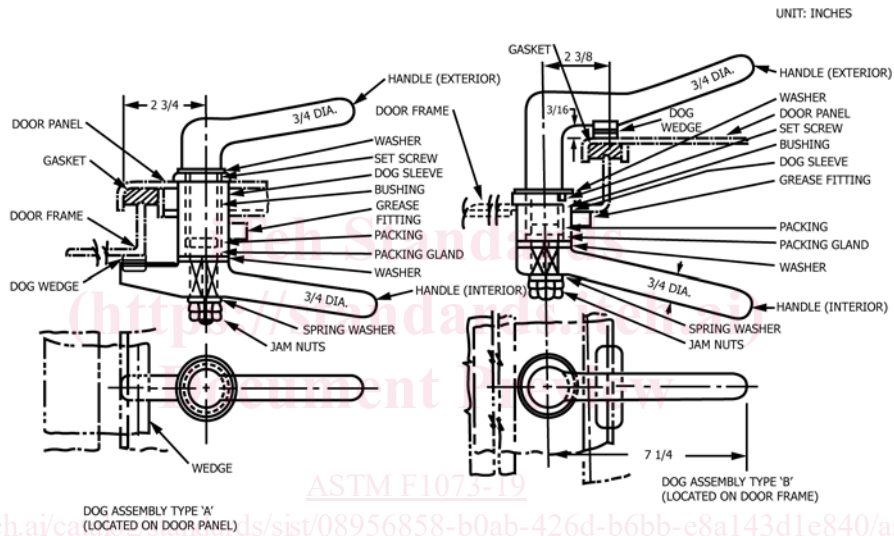

1 in. = 25.4 mm
2.2 lb = 1 kg

FIG. 1 Watertight, Airtight, and Weathertight Door Dog Assembly (Estimated Weight 8 lb)

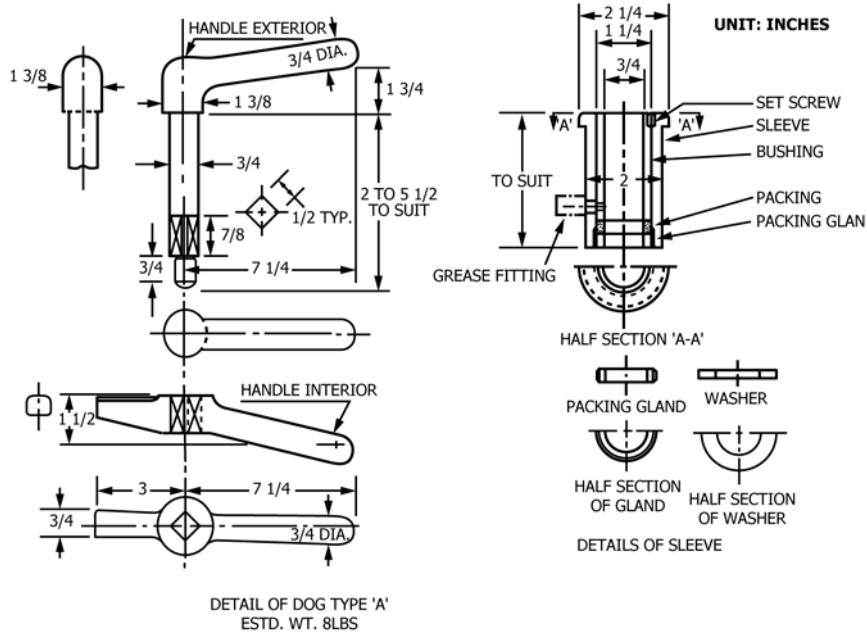

1 in. = 25.4 mm
2.2 lb = 1 kg

FIG. 2 Dog Details

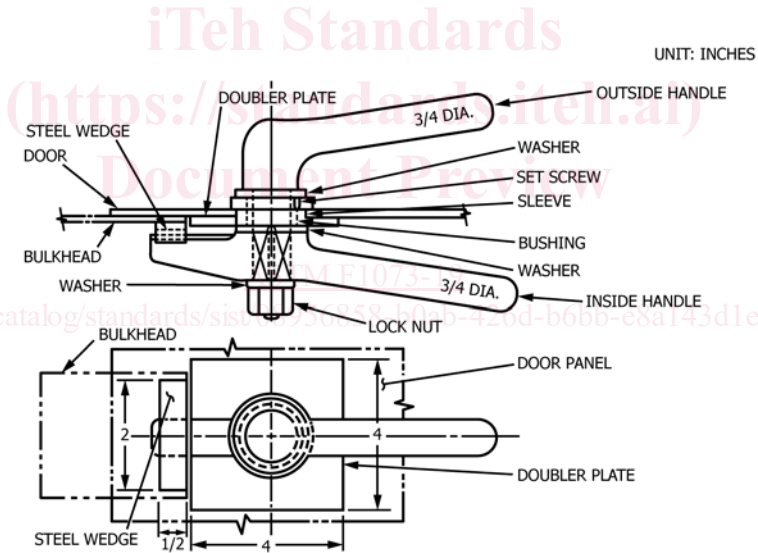

1 in. = 25.4 mm
2.2 lb = 1 kg

FIG. 3 Dog Assembly for Non-Tight Doors (Estimated Weight 8 lb)