



Standard Specification for Manhole Cover Assembly, Bolted, Raised, Oiltight and Watertight¹

This standard is issued under the fixed designation F1143; the number immediately following the designation indicates the year of original adoption or, in the case of revision, the year of last revision. A number in parentheses indicates the year of last reapproval. A superscript epsilon (ϵ) indicates an editorial change since the last revision or reapproval.

1. Scope

1.1 This specification provides design and construction criteria for a raised, bolted, oiltight and watertight manhole cover assembly.

1.2 The manhole cover assemblies depicted in this specification are for use in decks or bulkheads in which the manhole cover assemblies must be of the raised type. Manhole cover shall be complete with coaming, gasket, welded studs or bolts, washers, and nuts.

1.3 Determination of the use of handles will be as specified in the ordering information.

1.4 The values stated in inch-pound units are to be regarded as standard. The values given in parentheses are mathematical conversions to SI units that are provided for information only and are not considered standard.

1.5 This specification is not applicable to certain hazardous cargos (see 46 CFR 153.254 and 46 CFR 154.340).

1.6 This specification provides design and construction for manhole cover assemblies subjected to lateral pressures such as resulting from vehicle loads or hydrostatic pressures. Where manhole cover assemblies are subjected to primary or cyclic loads, other reinforcement or construction criteria may be necessary to integrate the manhole assembly with the required structural reinforcement for openings in decks or bulkheads. Design of the manhole cover assembly for primary or cyclic loads is beyond the scope of this specification.

1.7 *This international standard was developed in accordance with internationally recognized principles on standardization established in the Decision on Principles for the Development of International Standards, Guides and Recommendations issued by the World Trade Organization Technical Barriers to Trade (TBT) Committee.*

¹ This specification is under the jurisdiction of ASTM Committee F25 on Ships and Marine Technology and is the direct responsibility of Subcommittee F25.03 on Outfitting and Deck Machinery.

Current edition approved March 1, 2019. Published April 2019. Originally approved in 1988. Last previous edition approved in 2012 as F1143 – 98 (2012). DOI: 10.1520/F1143-19.

2. Referenced Documents

2.1 ASTM Standards:²

- A36/A36M Specification for Carbon Structural Steel
- A131/A131M Specification for Structural Steel for Ships
- A153/A153M Specification for Zinc Coating (Hot-Dip) on Iron and Steel Hardware
- B36/B36M Specification for Brass Plate, Sheet, Strip, and Rolled Bar
- D2000 Classification System for Rubber Products in Automotive Applications
- F783 Specification for Staple, Handgrab, Handle, and Stirrup Rung

2.2 ASME Standards:³

- B1.1 Unified Inch Screw Threads
- Y14.5M Dimensioning and Tolerancing
- B18.2.1 Square, Hex, Heavy Hex, and Askew Head Bolts and Hex, Heavy Hex, Hex Flange, Lobed Head, and Lag Screws (Inch Series)

2.3 ABS Standard:⁴

- Rules for Building and Classing Steel Vessels

2.4 SSPC Standard:⁵

- SP-10 Surface Preparation Specification No. 10

2.5 Code of Federal Regulations (CFR) Standard:⁶

- 46 CFR Title 46 of the Code of Federal Regulations

3. Terminology

3.1 Definitions:

- 3.1.1 *manhole, n*—an accessway located in a tank structure.

² For referenced ASTM standards, visit the ASTM website, www.astm.org, or contact ASTM Customer Service at service@astm.org. For *Annual Book of ASTM Standards* volume information, refer to the standard's Document Summary page on the ASTM website.

³ Available from American Society of Mechanical Engineers (ASME), ASME International Headquarters, Two Park Ave., New York, NY 10016-5990, <http://www.asme.org>.

⁴ Available from American Bureau of Shipping (ABS), ABS Plaza, 1701 City Plaza Dr., Spring, TX 77389, <http://www.eagle.org>.

⁵ Available from Society for Protective Coatings (SSPC), 800 Trumbull Dr., Pittsburgh, PA 15205, <http://www.sspc.org>.

⁶ Available from U.S. Government Printing Office, Superintendent of Documents, 732 N. Capitol St., NW, Washington, DC 20401-0001, <http://www.access.gpo.gov>.

3.1.2 *raised, n*—manhole cover seat is located on an angle or flat bar coaming which protrudes from the tank structure into the space from which it is accessed.

4. Classification

4.1 *Type I*—15- by 23-in. (381- by 584-mm) size of access opening. *Type II*—18- by 24-in. (457- by 610-mm) size of access opening.

4.2 *Grade 1*— $\frac{1}{4}$ -in. (6.35-mm) thick cover plate. *Grade 2*— $\frac{3}{8}$ -in. (9.5-mm) thick cover plate. *Grade 3*— $\frac{1}{2}$ -in. (13-mm) thick cover plate.

4.3 *Class A Manhole Cover Assemblies*—Class A manhole cover assemblies shall be abrasive blasted to near white metal in accordance with SSPC SP-10 and a commercial marine quality nonhazardous corrosion-inhibiting and oil-resistant primer coating be applied for protection for a period of one year during shipping and in shipyard handling.

4.4 *Class B Manhole Cover Assemblies*—Class B manhole cover assemblies shall be galvanized in accordance with Specification **A153/A153M**.

5. Ordering Information

5.1 The purchasers' ordering information shall include the following information:

- 5.1.1 ASTM designation and year of issue,
- 5.1.2 Type (see 4.1),
- 5.1.3 Grade (see 4.2),
- 5.1.4 Class (see 4.3 and 4.4),
- 5.1.5 Shape (rectangular or oval) (see Fig. 1 and Fig. 2),
- 5.1.6 Quantity,
- 5.1.7 *Remarks*—Handles (are/are not) required, and
- 5.1.8 *Approval*—Classification society approval (is/is not) required.
- 5.1.9 Gasket, if other than specified (see 6.7).

6. Materials and Manufacture

6.1 Plate for the cover to be of Specifications **A36/A36M** or **A131/A131M** steel.

6.2 Coaming to be of Specifications **A36/A36M** or **A131/A131M** steel.

6.3 Round bar for the handle shall be in accordance with Specification **F783**, Type A.

6.4 Bolts shall be $\frac{3}{4}$ in. (19.05 mm) by $2\frac{1}{4}$ in. (57 mm) long. Welded studs shall be $\frac{3}{4}$ in. (19.05 mm) by $1\frac{3}{4}$ in. (44.4 mm) long. Bolts or welded studs shall be manufactured of ordinary steel to commercial standards. Threads shall be the coarse thread series as specified in the latest issue of ASME B1.1.

6.5 Washers shall be ASME B18.2.1 Type A, $\frac{3}{4}$ -in. (19.05-mm) washer, 2-in. (50.8-mm) by 0.148-in. (3.8-mm) thick standard flat manufactured of yellow brass, Specification **B36/B36M**.

6.6 Heavy hex nuts shall be $\frac{3}{4}$ in. (19.05 mm) and manufactured of yellow brass, Specification **B36/B36M**. Threads in nuts shall conform to the dimensions for coarse threads with

tolerances prescribed in ASME B1.1. The nut shall conform to dimensions prescribed in ASME B18.2.1.

6.7 Unless otherwise specified in ordering information, gasket shall be rubber, $\frac{3}{16}$ in. (4.8 mm) thick, 50 ± 5 durometer, or other such classification society rules as may be applicable. Manhole cover assemblies for government application see **Annex A2** for type of gaskets.

6.8 Welding to conform to the latest issue of the American Bureau of Shipping Rules in accordance with Classification **D2000 5BC507 A14 E034**.

6.9 Details of bolted manhole cover assembly is shown in **Fig. 1** and **Fig. 2**.

7. Dimensions and Permissible Variations

7.1 Dimensions of manhole assembly shall be as indicated in **Table 1** and **Table 2**.

7.2 For plating up to and including $\frac{1}{4}$ -in. (6.4-mm) thickness, use cover plate of $\frac{1}{4}$ -in. (6.4-mm) thickness. Plating over $\frac{1}{4}$ -in. (6.4-mm) up to, and including $\frac{3}{8}$ -in. (9.5-mm) thickness, use cover plate of $\frac{3}{8}$ -in. (9.5-mm) thickness. Plating over $\frac{3}{8}$ -in. (9.5-mm) thickness, use cover plate of $\frac{1}{2}$ -in. (12.7-mm) thickness.

8. Workmanship, Finish, and Appearance

8.1 Items produced under this specification shall be free of splinters, sharp edges, burrs, projections, and weld spatters.

9. Sampling

9.1 For orders for one or two manhole cover assemblies, each manhole cover assembly shall be inspected.

9.2 For orders for three to ten manhole cover assemblies, two manhole cover assemblies shall be selected at random. If any one of them fails to meet requirements, then all manhole cover assemblies in the order shall be inspected.

9.3 For orders for more than ten manhole cover assemblies, they shall be separated into groups of ten (or fraction thereof) for sampling purposes.

10. Inspection and Testing

10.1 *Responsibility*—Unless otherwise in the order, the manufacturer is responsible for the performance of all inspection and testing specified herein. The manufacturer may use the manufacturer's own facilities or any commercial facility acceptable to the purchaser. The purchaser reserves the right to perform any of the inspections and tests set forth where such are deemed necessary to assure that supplies conform to prescribed requirements. Nonconforming manhole cover assemblies shall not be offered for delivery.

10.2 *Inspection*—The dimensions of the manhole cover assembly and its components shall be checked to ensure that they are within specified tolerances.

10.3 *Test Method*—Each manhole cover assembly shall be designed to the pressure listed in **Table 1** and **Table 2** and tested to a pressure equal to 1.5 times the design pressure. The test pressure shall be held for a minimum of 5 min. There shall be

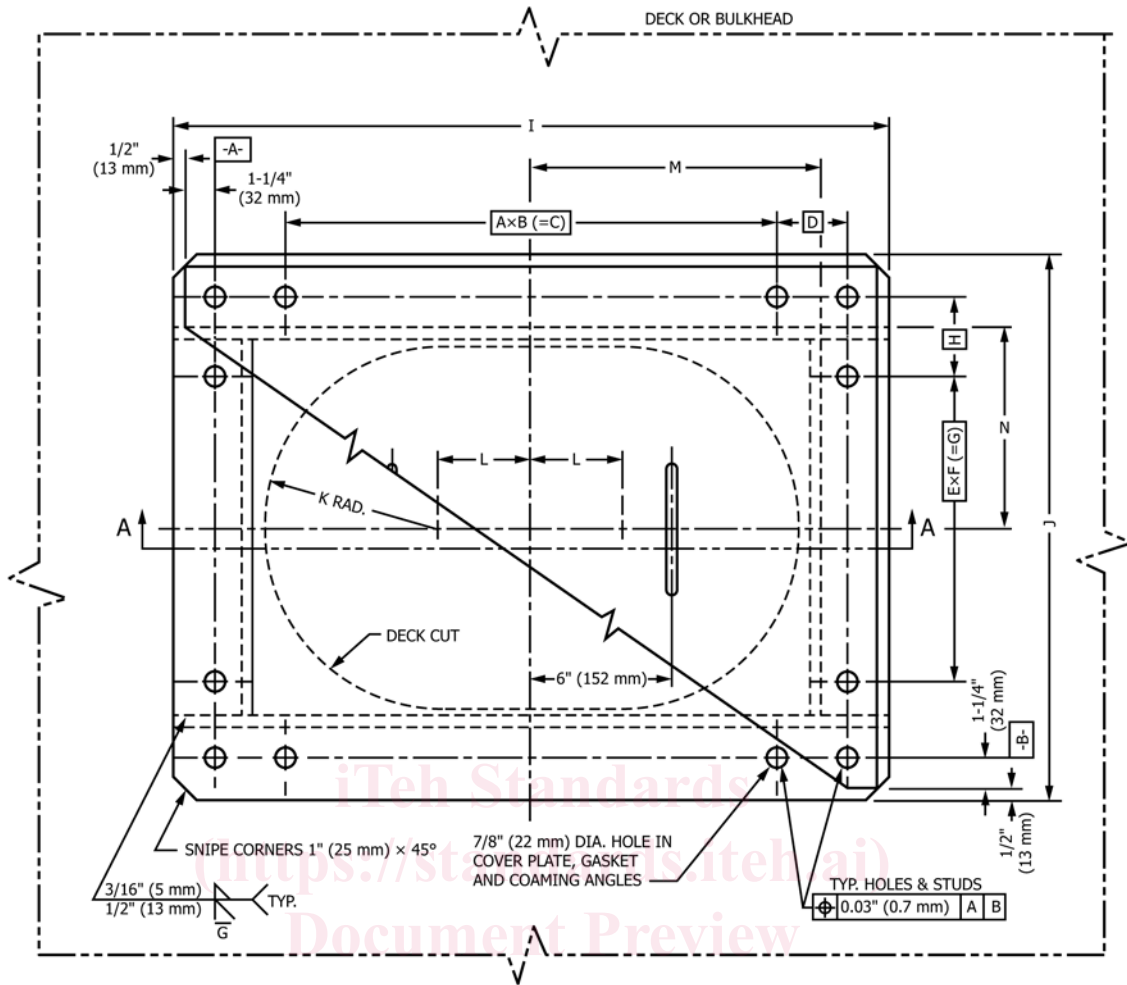

ASTM F1143-19

<https://standards.iteh.ai/catalog/standards/sist/d195d55a-7fec-480a-836d-66b4ef7ed2f/astm-f1143-19>

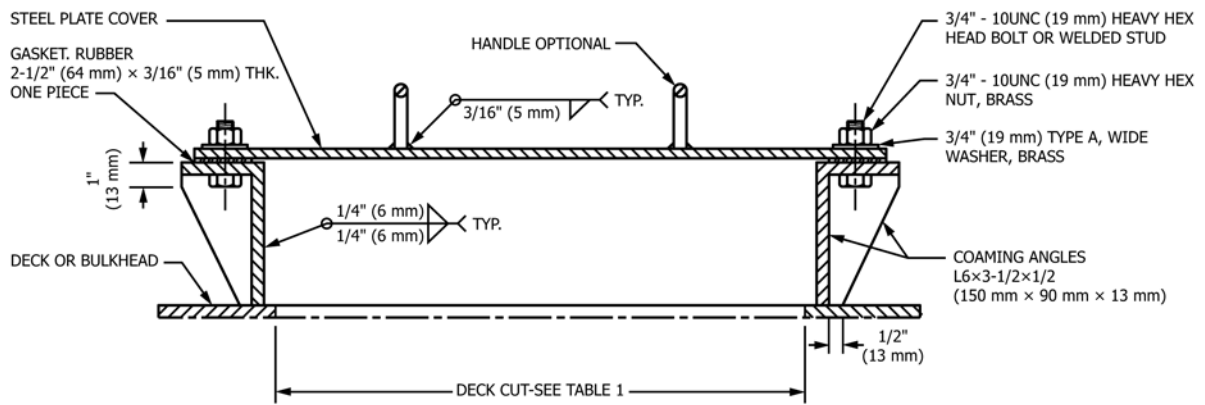

SECTION "A-A"

NOTE 1—See Table 1 for manhole cover assembly dimensions.
1 in. = 25.4 mm.

FIG. 1 Rectangular Manhole Cover Assembly, Raised, Bolted, Oiltight and Watertight

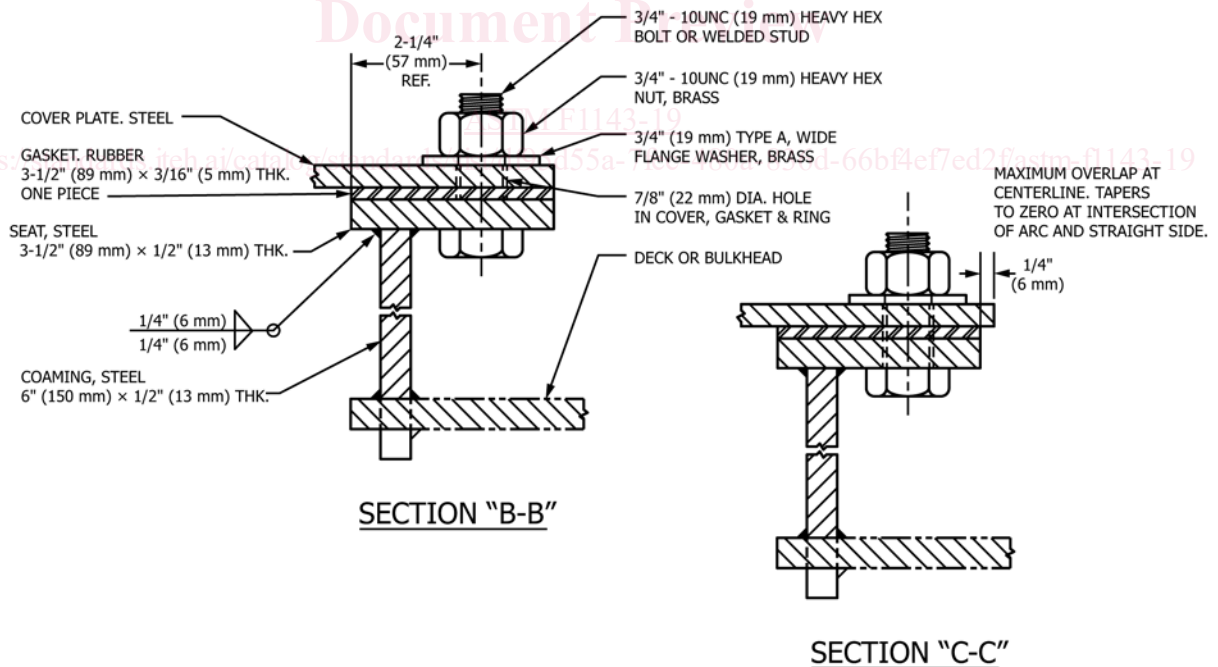
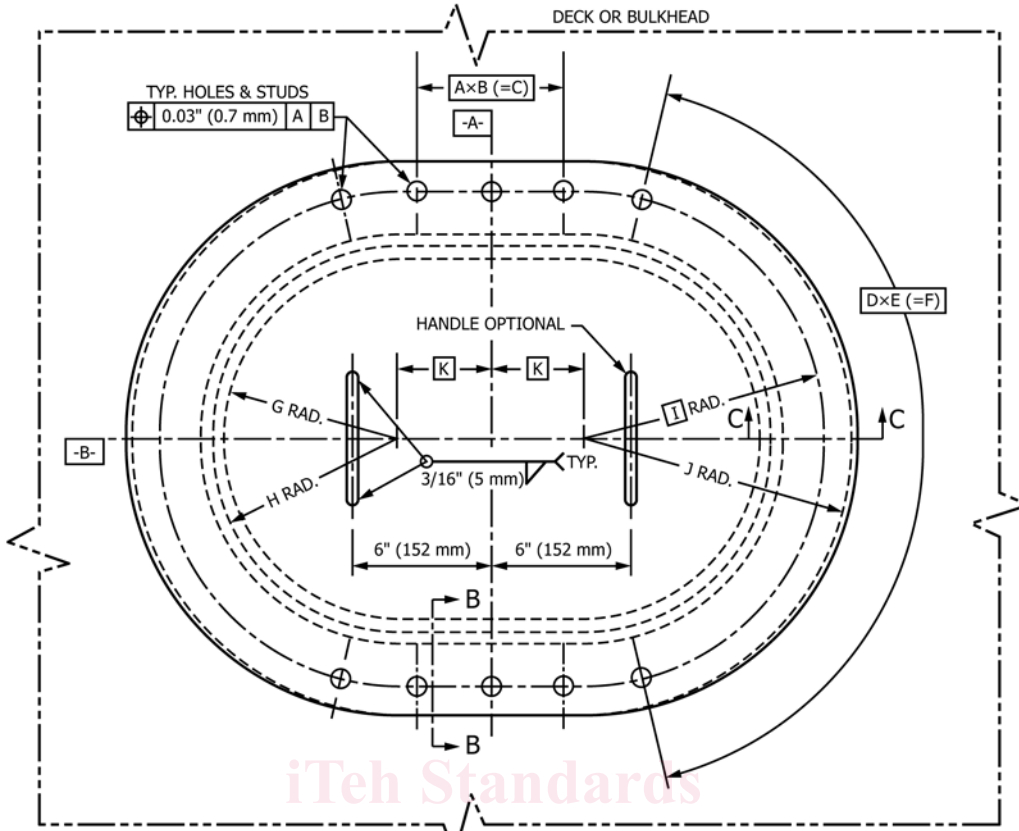

NOTE 1—See Table 2 for manhole cover assembly dimensions.
1 in. = 25.4 mm.

FIG. 2 Oval Manhole Cover Assembly, Raised, Bolted, Oiltight and Watertight