



Designation: A937/A937M – 12 (Reapproved 2019)

# Standard Test Method for Determining Interlaminar Resistance of Insulating Coatings Using Two Adjacent Test Surfaces<sup>1</sup>

This standard is issued under the fixed designation A937/A937M; the number immediately following the designation indicates the year of original adoption or, in the case of revision, the year of last revision. A number in parentheses indicates the year of last reapproval. A superscript epsilon ( $\epsilon$ ) indicates an editorial change since the last revision or reapproval.

## 1. Scope

1.1 This test method covers a means of testing the interlaminar resistance of electrically insulating coatings as applied to adjacent laminations of flat-rolled electrical steel, under predetermined conditions of voltage, pressure and temperature. It indicates the effectiveness of surface coatings on electrical sheet steels for limiting interlaminar losses in electrical machinery. The interlaminar resistance is measured directly in units of resistance ( $k\Omega$ ).

1.2 This test method is particularly useful for, but not limited to, electrical steels coated with inorganic insulating coatings.

1.3 The values and equations stated in customary (cgs-emu and inch-pound) or SI units are to be regarded separately as standard. Within this standard, SI units are shown in brackets. The values stated in each system may not be exact equivalents; therefore, each system shall be used independently of the other. Combining values from the two systems may result in nonconformance with this standard.

1.4 *This standard does not purport to address all of the safety concerns, if any, associated with its use. It is the responsibility of the user of this standard to establish appropriate safety, health, and environmental practices and determine the applicability of regulatory limitations prior to use.*

1.5 *This international standard was developed in accordance with internationally recognized principles on standardization established in the Decision on Principles for the Development of International Standards, Guides and Recommendations issued by the World Trade Organization Technical Barriers to Trade (TBT) Committee.*

<sup>1</sup> This test method is under the jurisdiction of ASTM Committee A06 on Magnetic Properties and is the direct responsibility of Subcommittee A06.01 on Test Methods.

Current edition approved April 1, 2019. Published April 2019. Originally approved in 1995. Last previous edition approved in 2012 as A937/A937M – 12. DOI: 10.1520/A0937\_A0937M-12R19.

## 2. Referenced Documents

2.1 *ASTM Standards:*<sup>2</sup>

A34/A34M Practice for Sampling and Procurement Testing of Magnetic Materials

A717/A717M Test Method for Surface Insulation Resistivity of Single-Strip Specimens

## 3. Terminology

3.1 *Definitions of Terms Specific to This Standard:*

3.1.1 *bad contact*—a contact which results in a voltage drop in excess of 0.6 V as described in 6.1.3.

3.1.2 *exposed test surface*—the insulating top surface of the top lamination or the insulating bottom surface of the bottom lamination of the test specimen.

3.1.3 *four-terminal measuring technique, often referred to as four-probe measuring technique*—a common method to measure resistance when a high degree of accuracy is required.<sup>3</sup> In this standard, the circuit configuration for this technique is referred to as a *four-probe configuration*. In the two-surface tester, this configuration features two probes connected to the top lamination test surface and two probes connected to the bottom lamination test surface. One of the probes in each pair carries the measuring current, and the other provides a contact for the voltage measurement. Because of the extremely high impedance of the measuring circuit, very little current flows through the voltage contacts, and thus very little voltage is produced across the contacts to influence the true reading, that is, any effect from contact resistance is avoided or reduced to a negligible amount. The two-surface tester has provision to check the integrity of the contacts made between the probes and the test surfaces.

<sup>2</sup> For referenced ASTM standards, visit the ASTM website, [www.astm.org](http://www.astm.org), or contact ASTM Customer Service at [service@astm.org](mailto:service@astm.org). For *Annual Book of ASTM Standards* volume information, refer to the standard's Document Summary page on the ASTM website.

<sup>3</sup> Harris, F. K., *Electrical Measurements*, Robert E. Krieger Publishing Company, Huntington, New York, 1975, pp. 220–224.

3.1.4 *interlaminar resistance*—the average resistance of two adjacent insulating surfaces in contact with each other, under conditions specified in this standard.

3.1.5 *surface insulation resistivity*—the effective resistivity of a single insulating layer tested between applied bare metal contacts and the base metal of the insulated test specimen, as per Test Method A717/A717M.

3.1.6 *test specimen*—two electrical steel laminations, each having a minimum size of 25 × 25 cm [250 × 250 mm] and each having an electrically insulating coating on both sides. The two electrical steel laminations are placed one on top of the other for the interlaminar resistance measurement, Fig. 1.

3.1.7 *two-surface tester*—the apparatus used in this test method.

#### 4. Summary of Test Method

4.1 The test method measures the average resistance of two adjacent insulating surfaces. Intimate physical contact of these surfaces is achieved via test heads which force a defined surface area into contact under a specified pressure. For the interlaminar resistance measurement, electrical contact is established between the test specimen and a constant direct

current source using metallic contacts (drill bits). The tester utilizes two sets of metallic contacts which penetrate the exposed test surfaces into the base metal, to form a four-probe configuration, Fig. 1. A continuous electrical path is formed between the contacts and constant current source when the metallic contacts penetrate through the coating on the exposed test surfaces to the underlying base metal, and the insulating surfaces are held in intimate contact by the test head. When current flows in the circuit, the dc voltage developed in the circuit may be easily measured by means of a digital voltmeter. A block diagram of the two-surface test system is illustrated in Fig. 2.

NOTE 1—The current range settings for the two-surface tester are 1- $\mu$ A dc and 10- $\mu$ A dc, thus enabling the resistance to be read directly from the voltmeter. The current select switch is designed to shift the decimal point appropriately so as to provide a resistance reading in units of k $\Omega$ .

#### 5. Significance and Use

5.1 This test method is particularly suitable for quality control in the application of insulating coatings. This test method measures the interlaminar resistance of insulating coatings, as defined in 3.1.4. Interlaminar resistance is the

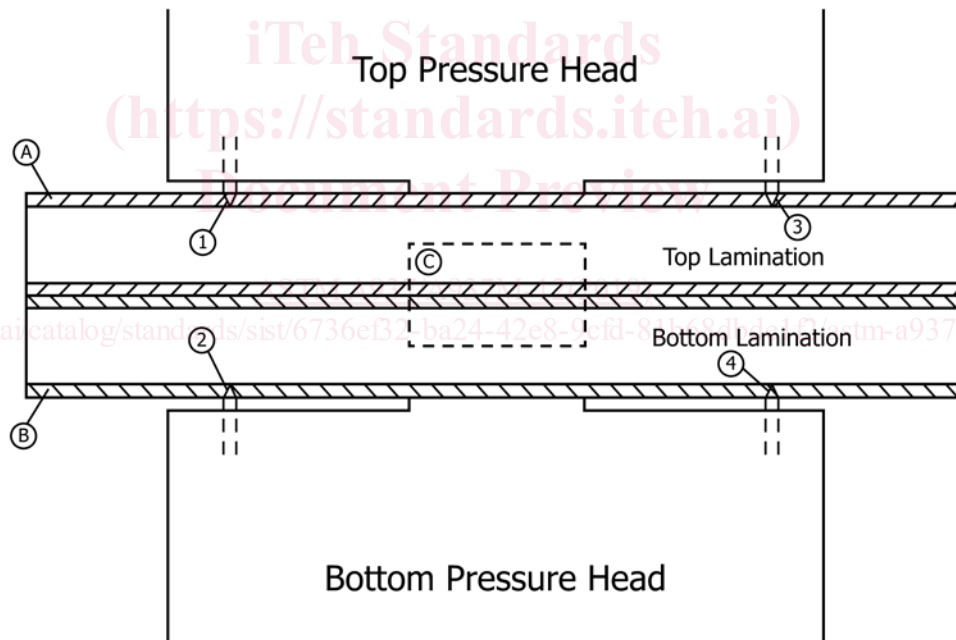

Exposed Test Surfaces: A and B  
 Insulating Coating Layers Under Test: C

Metallic Contacts Carrying Current: 1 and 2  
 Metallic Contacts Measuring Voltage: 3 and 4

Note: Contacts pierce insulating coating and contact substrate

FIG. 1 Schematic Illustration of Four-Probe Configuration

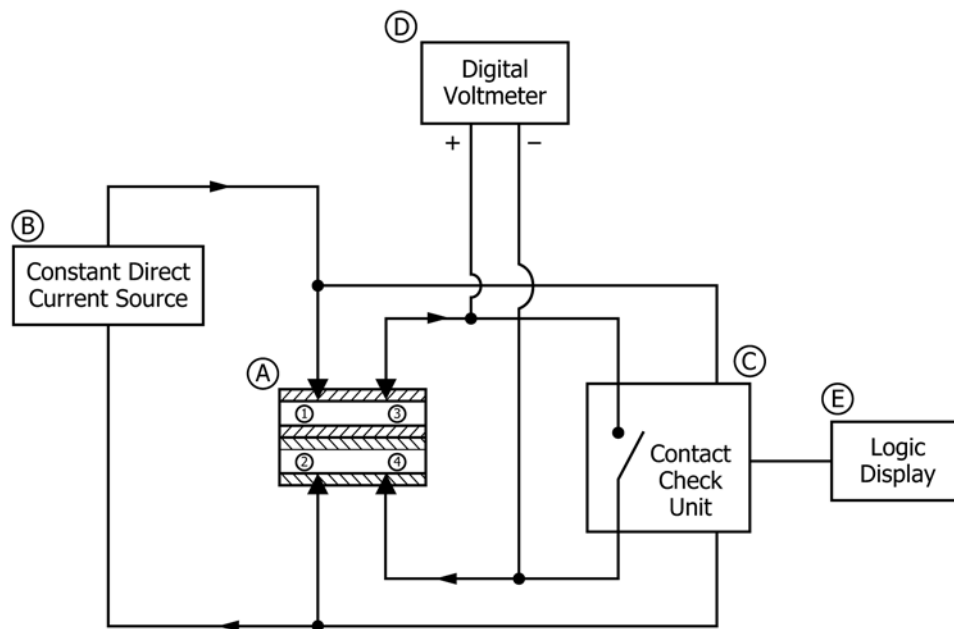

- A Test Specimen and Measuring Probes in Four-Probe Configuration. (As shown in Figure 1)
- B Constant Direct Current Source with Two Current Settings: 1  $\mu\text{A}$  and 10  $\mu\text{A}$ .
- C Contact Check Unit: Circuit which verifies that contact resistance of test probes will not interfere with coating resistance measurement.
- D Digital Voltmeter: Voltmeter measuring voltage drop through contacts or coating.  
Calibration Module: The module is a set of precision resistors which substitutes known resistances for the purpose of calibration. (Not shown.)

FIG. 2 Block Diagram of Two-Surface Test System

measure of the insulating quality of the coating. Interlaminar resistance is reported in units of  $\text{k}\Omega$ .

5.2 The interlaminar resistance determined in accordance with this test method is not the same quantity determined by Test Method A717/A717M.

5.3 This test method is particularly useful for electrical steels coated with inorganic insulating coatings having surface insulation resistivities in excess of  $0.3 \text{ k}\Omega\cdot\text{cm}^2$  [ $30 \text{ k}\Omega\cdot\text{mm}^2$ ] when tested using Test Method A717/A717M (a Franklin current less than 0.02 A). This test method can readily be extended to any range of insulation resistivity that the equipment comprising the two-surface tester allows. For the equipment specified herein, the maximum measurable resistance is  $1200 \text{ k}\Omega$  for the  $10\text{-}\mu\text{A}$  current setting and  $12\,000 \text{ k}\Omega$  for the  $1\text{-}\mu\text{A}$  current setting; the maximum voltage for the test system is 12 V.

5.4 Repeat readings on the same set of two electrical steel laminations using different contact positions, as well as the testing of multiple laminations from the same lot of electrical steel, are recommended. Several readings are suggested because the coating thickness may vary across the surface of a

given electrical steel lamination. Additionally, the coating thickness may vary across several laminations taken from the same lot of electrical steel. Such variations in coating thickness are likely to yield variations in the measured interlaminar resistance. The required number of readings depends on the nature of the coating and the accuracy required.

## 6. Apparatus

6.1 The two-surface tester measures the resistance between two laminations that are in intimate contact with one another as shown in Fig. 1. The two-surface tester shall consist of two pressure pads, each of which is mounted to one of the heads of a hydraulic or pneumatic press. The diameter of each pressure pad is 3.57 cm [35.7 mm], giving a nominal area of  $10 \text{ cm}^2$  [ $1000 \text{ mm}^2$ ]. The diameter of the pressure head is 11.50 cm [115 mm]. Each pressure head circumscribes two metallic contacts (drill bits) which are used to make contact with the test specimen. A schematic diagram of the pressure head, pads and metallic contacts is shown in Fig. 3. Commercially available rollnut actuators, which convert rotary to linear motion, can be used to house and rotate the drill bit through the coating on the exposed surfaces of the test specimen, Fig. 4.