



SLOVENSKI STANDARD
SIST ISO 4386-2:2002

01-marec-2002

8 fgb]`YÿU]!'JY g`c`b]`_cj]bg_]`YÿU]!'&"XY'.`DfYg_i yUb`Y'a YXg`c`bY[Ugdc`U`
`YÿU`bY[U`_cj]bg_Y[Ug`c`UXYVY]bY`û&a a `g`dcfi y]hj]c`

Plain bearings -- Metallic multilayer plain bearings -- Part 2: Destructive testing of bond for bearing metal layer thicknesses greater than or equal to 2 mm

iTeh STANDARD PREVIEW

Paliers lisses -- Paliers lisses métalliques multicouches -- Partie 2: Détermination, par essai destructif, de l'adhérence du matériau antifriction d'épaisseur supérieure ou égale à 2 mm

[SIST ISO 4386-2:2002](https://standards.iteh.ai/catalog/standards/sist/5ba5ebf-ec07-47f0-a7f1-b206e0d596b9/sist-iso-4386-2-2002)

[https://standards.iteh.ai/catalog/standards/sist/5ba5ebf-ec07-47f0-a7f1-](https://standards.iteh.ai/catalog/standards/sist/5ba5ebf-ec07-47f0-a7f1-b206e0d596b9/sist-iso-4386-2-2002)

[b206e0d596b9/sist-iso-4386-2-2002](https://standards.iteh.ai/catalog/standards/sist/5ba5ebf-ec07-47f0-a7f1-b206e0d596b9/sist-iso-4386-2-2002)

Ta slovenski standard je istoveten z: ISO 4386-2:1982

ICS:

21.100.10

Drsni ležaji

Plain bearings

SIST ISO 4386-2:2002

en

iTeh STANDARD PREVIEW
(standards.iteh.ai)

[SIST ISO 4386-2:2002](https://standards.iteh.ai/catalog/standards/sist/5ba5ebf-ec07-47f0-a7f1-b206e0d596b9/sist-iso-4386-2-2002)

<https://standards.iteh.ai/catalog/standards/sist/5ba5ebf-ec07-47f0-a7f1-b206e0d596b9/sist-iso-4386-2-2002>

International Standard



4386/2

INTERNATIONAL ORGANIZATION FOR STANDARDIZATION • МЕЖДУНАРОДНАЯ ОРГАНИЗАЦИЯ ПО СТАНДАРТИЗАЦИИ • ORGANISATION INTERNATIONALE DE NORMALISATION

Plain bearings — Metallic multilayer plain bearings — Part 2 : Destructive testing of bond for bearing metal layer thicknesses ≥ 2 mm

Paliers lisses — Paliers lisses métalliques multicouches — Partie 2 : Détermination, par essai destructif, de l'adhérence du matériau antifriction d'épaisseur ≥ 2 mm

First edition — 1982-02-01

(standards.iteh.ai)

SIST ISO 4386-2:2002

<https://standards.iteh.ai/catalog/standards/sist/5ba5ebf-ec07-47f0-a7f1-b206e0d596b9/sist-iso-4386-2-2002>

UDC 669.018.24-419 : 620.172/.173

Ref. No. ISO 4386/2-1982 (E)

Descriptors : bearings, plain bearings, bearing alloys, bonding, tests, mechanical tests, adhesion tests, tension tests, compression tests, destructive tests, dimensions, dimensional tolerances.

Foreword

ISO (the International Organization for Standardization) is a worldwide federation of national standards institutes (ISO member bodies). The work of developing International Standards is carried out through ISO technical committees. Every member body interested in a subject for which a technical committee has been set up has the right to be represented on that committee. International organizations, governmental and non-governmental, in liaison with ISO, also take part in the work.

Draft International Standards adopted by the technical committees are circulated to the member bodies for approval before their acceptance as International Standards by the ISO Council.

International Standard ISO 4386/2 was developed by Technical Committee ISO/TC 123, *Plain bearings*, and was circulated to the member bodies in March 1979.

It has been approved by the member bodies of the following countries :

| | | |
|---------------------|------------------------|----------------|
| Bulgaria | Italy | Spain |
| Chile | Korea, Rep. of | Sweden |
| Czechoslovakia | Libyan Arab Jamahiriya | Turkey |
| Egypt, Arab Rep. of | Netherlands | United Kingdom |
| France | New Zealand | USA |
| Germany, F.R. | Poland | USSR |
| India | South Africa, Rep. of | |

No member body expressed disapproval of the document.

Plain bearings — Metallic multilayer plain bearings — Part 2 : Destructive testing of bond for bearing metal layer thicknesses ≥ 2 mm

1 Scope and field of application

This part of ISO 4386 specifies a method of test for the determination of the bond strength between the bearing metal and the backing. The test can be applied to multilayer plain bearings with backings of steel, cast iron, or copper alloys and with bearing metals based on lead, tin, copper, or aluminium with layer thicknesses of ≥ 2 mm.

The test is suitable for production control as well as for comparative investigations into the influence on the bond strength of various processes and types of material.

For non-destructive ultrasonic testing of the bond between bearing metal and backing for bearing metal layer thicknesses > 2 mm, see ISO 4386/1.

2 Reference

ISO 4381, *Plain bearings — Lead and tin casting alloys for multilayer plain bearings.*

3 Definition

During the compressive or tensile tests carried out vertically to the bond surface, the bond strength R_{Ch} ¹⁾ in newtons per square millimetre is the quotient of the maximum force F_{max} in newtons and the bond surface A in square millimetres of the specimen.

$$R_{Ch} = \frac{F_{max}}{A}$$

4 Test equipment

Compressive or tensile testing machine with apparatus in accordance with figures 2 or 3.

NOTE Within 5 years it shall be decided which of the two testing machines is to be preferred.

By means of careful adjustment of the apparatus, it shall be ensured that the force is acting vertically to the bond surface in order to avoid incorrect measurements.

5 Specimen preparation

Specimens from a journal bearing (curved sliding surface) or a thrust bearing (plane sliding surface) are manufactured in accordance with the table. Care has to be taken at the shoulders adjacent to the joint of the specimen that the bond surface is unencumbered for 0,1 mm at the inside as well as at the outside of the bearing as shown in figure 1.

6 Operation

The apparatus as shown in figure 2 or 3 is mounted on the compressive or tensile testing machine in such a way that the force acts vertically to the bond surface. Subsequently, the specimen is locked into the apparatus. The force is steadily increased until the specimen fractures. The maximum force is read from the testing apparatus.

The increase in stress should be at about 10 N/mm².s.

1) The subscript Ch refers to the test method proposed by Chalmers.

Table — Dimensions and tolerances (see figures 1, 2 and 3)

Dimensions in millimetres

| Journal bearing | Journal and thrust bearing | | | | | | | |
|--|---------------------------------|------------|------------|----------------|-------|----------------|----------------|-------|
| | Test surface mm ² | Specimen | | | | Apparatus | | |
| | | d_2 | d_3 | d_4 | d_5 | d_6 | d_7 | d_8 |
| Inner diameter of the bearing d_1 | \approx | $\pm 0,01$ | $\pm 0,01$ | $+ 0,1$ 0 | | $+ 0,1$ 0 | 0 $- 0,1$ | |
| ≤ 200 | 100 | 19,58 | 16 | 8,1 | 29 | 19,7 | 15,9 | M8 |
| > 200 | 200 | 28,82 | 24 | 12,1 | 38 | 29 | 23,9 | M12 |

NOTES

- For journal bearings, the inner diameter d_1 is the critical parameter for selection of dimensions for the specimen and apparatus. For thrust bearings, a test surface of 100 mm² or 200 mm² may be chosen as desired.
- Details not indicated are to be chosen accordingly.

iTeh STANDARD PREVIEW (standards.iteh.ai)

Dimensions in millimetres

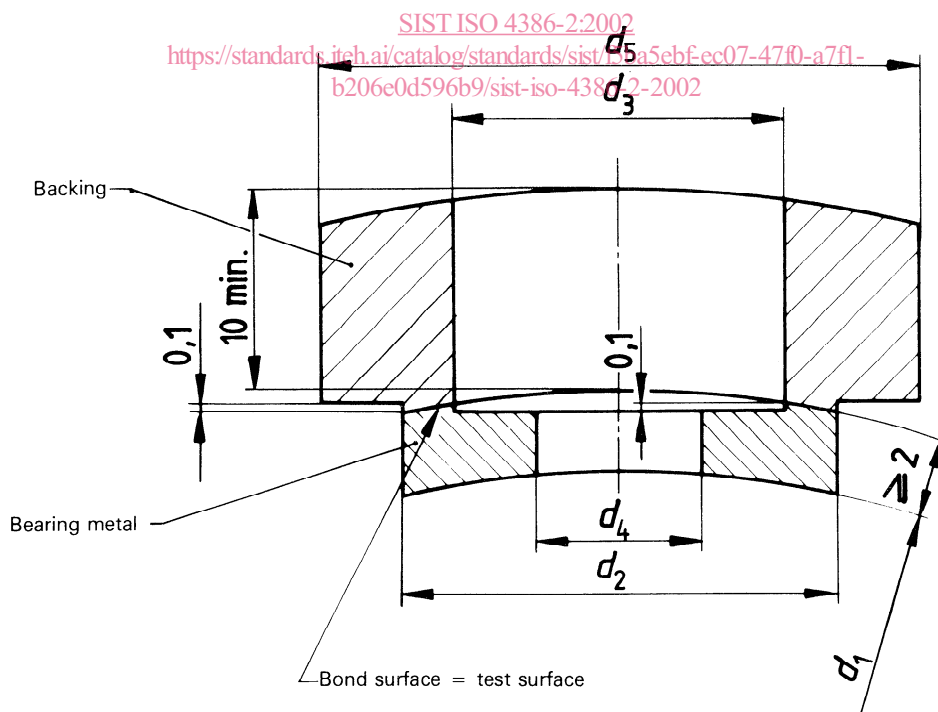

Figure 1 — Specimen (from a journal bearing)

Dimensions in millimetres

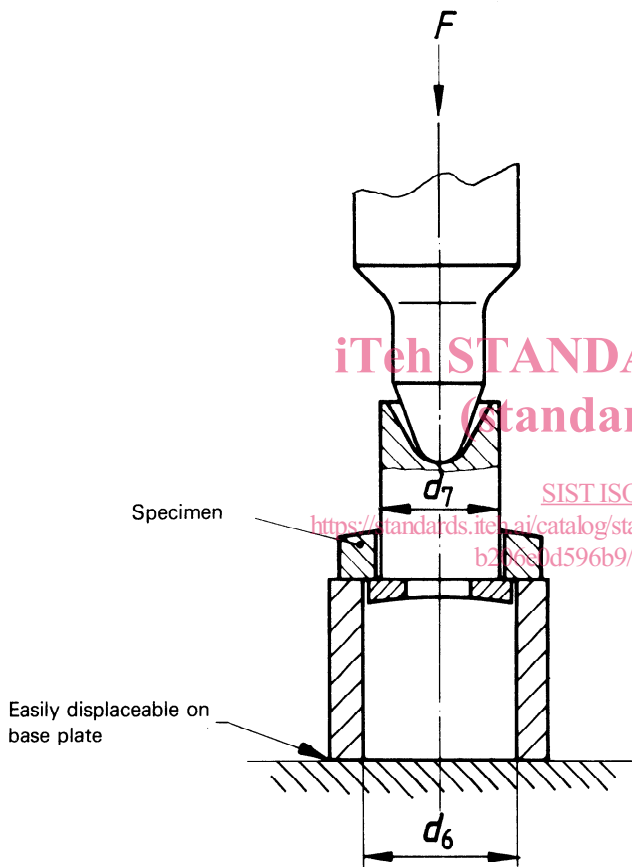

Figure 2 — Example of apparatus for the compressive test (C)

iTeh STANDARD PREVIEW
(standards.iteh.ai)

SIST ISO 4386-2:2002

<https://standards.iteh.ai/catalog/standards/sist/5ba5ebf-ec07-47f9-a711-b28881d596b9/sist-iso-4386-2-2002>

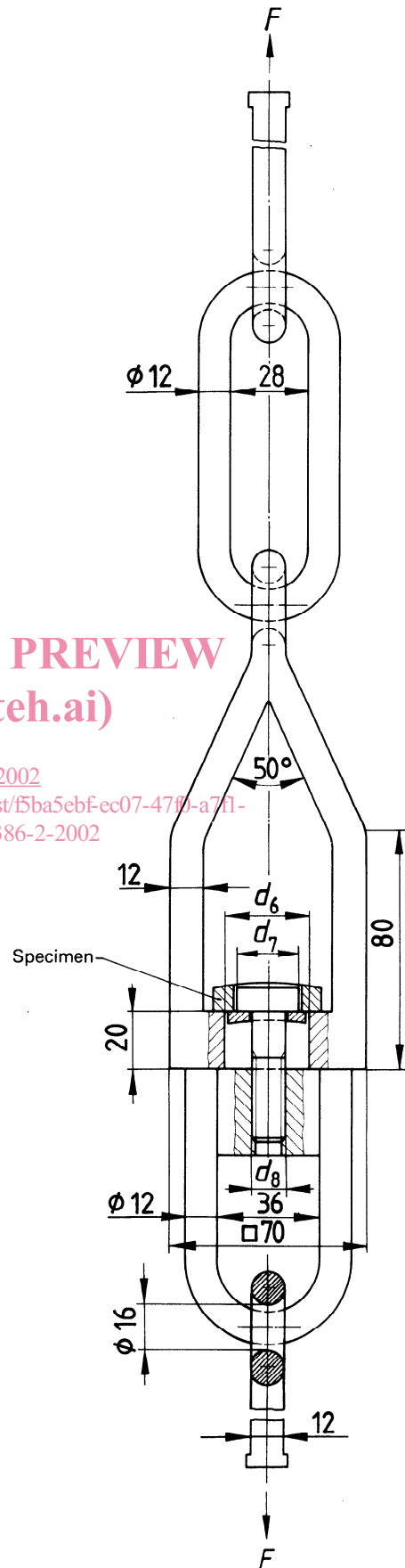

Figure 3 — Example of apparatus for the tensile test (T)

7 Evaluation

With the aid of the maximum force F_{max} , found necessary to tear the bearing metal away from the backing in the region of the bond surface, the bond strength R_{Ch} is to be determined according to the equation in clause 3. Specimens are only evaluated when the fracture has occurred in the bond surface or in the bearing metal. Existing bond defects have to be noted.

The characteristic limiting value of layer thickness for the absolute bond strength is a property of the bearing metal.

The thickness of the bearing metal layer as from which the absolute bond strength is measured, is included in ISO 4381 for standardized Pb and Sn alloys. This value must be determined for all alloys in a series of tests with different thicknesses of the bearing material layers.

NOTE — For layer thicknesses of the bearing metal above the characteristic limiting value, the bond strength is independent of the layer thickness and is termed absolute bond strength whereas, for layer thicknesses below this limiting value, it has been established experimentally that it drops linearly to the value zero and, in this range, is termed relative bond strength (see figure 4).

This gives rise to the evaluation procedure :

- a) layer thickness \geq limiting value

The value found is compared directly with the absolute value of the bond strength.

- b) layer thickness $<$ limiting value

As shown in figure 4 as an example, the value found is converted into the real value of the bond strength and compared with the absolute value of the bond strength.

8 Designation

With reference to this part of ISO 4386, the tensile test (represented by T) is to be indicated in the following order, for example for a test surface of 100 mm² :

Test ISO 4386 — T 100

9 Test report

A test report on the result of the test is (by agreement) to be drawn up.

In the test report the following are to be indicated :

- a reference to this part of ISO 4386;
- number of specimens;
- dimensions and materials of the plain bearing;
- layer thickness of the bearing metal for the test;
- test surface used;
- maximum force applied until fracture of the specimen;
- description of the condition of the fractured surface;
- bond strength determined;
- test conditions;
- bearing manufacturer, date of test.

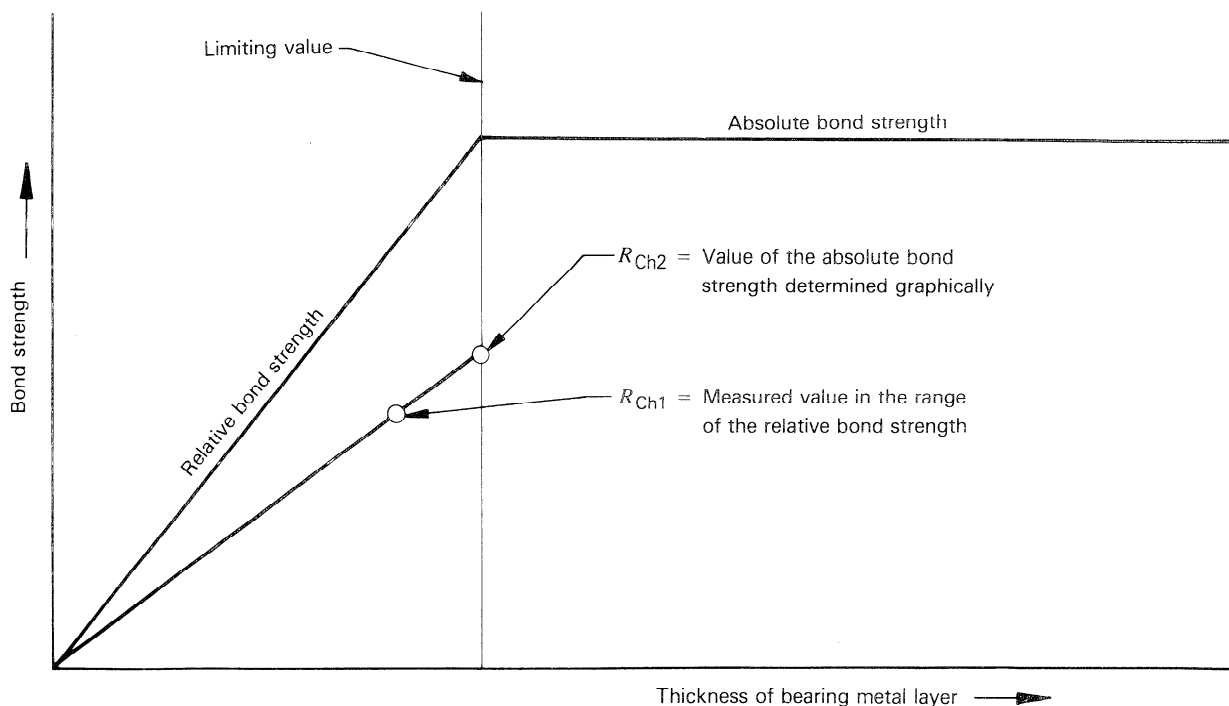

Figure 4 — Principle curve of the bond strength as a function of the thickness of the bearing metal layer