



Designation: **F2879 – 18 F2879 – 19**

Standard Specification for Eye Protective Devices for Airsoft Sports¹

This standard is issued under the fixed designation F2879; the number immediately following the designation indicates the year of original adoption or, in the case of revision, the year of last revision. A number in parentheses indicates the year of last reappraisal. A superscript epsilon (ϵ) indicates an editorial change since the last revision or reappraisal.

1. Scope

1.1 This specification applies to eye protective devices (EPDs) designed for use by participants in the sport of airsoft with 6-mm airsoft projectiles. These EPDs are designed to minimize or significantly reduce injury to the eye and adnexa as a result of impact and penetration of airsoft projectiles.

1.2 When airsoft guns are used for target practice with a paper or gel target and a backstop sufficient to prevent ricochet, shooters may wear eye protection (shooting glasses) appropriate for use with firearms, ball bullet (BB) guns or air guns that meet ANSI Z87.1. The balance of this specification applies to EPDs designed for use by participants in tactical sports using airsoft guns.

1.3 EPDs meeting the requirements of this specification offer protection to the eyes and adnexa and not necessarily to any other parts of the head.

1.4 This specification does not limit the wearing of eyeglasses or contact lenses when used in conjunction with the EPD based on the information provided by the manufacturer in [9.2.21](#).

1.5 *Units*—The values stated in SI units are to be regarded as the standard. No other units of measurement are included in this standard.

1.6 The following information is provided for the laboratory conducting the test for the protection of their personnel: *This standard does not purport to address all of the safety concerns, if any, associated with its use. It is the responsibility of the user of this standard to establish appropriate safety, health, and environmental practices and determine the applicability of regulatory limitations prior to use.*

1.7 *This international standard was developed in accordance with internationally recognized principles on standardization established in the Decision on Principles for the Development of International Standards, Guides and Recommendations issued by the World Trade Organization Technical Barriers to Trade (TBT) Committee.*

2. Referenced Documents

2.1 *ASTM Standards:*² <https://standards.ahai/catalog/standards/sist/8d0956a5-08da-4876-a81b-c70d9bd04860/astm-f2879-19>

[D1003 Test Method for Haze and Luminous Transmittance of Transparent Plastics](#)

[F2679 Specification for 6 mm Projectiles Used with Airsoft Guns](#)

[F2748 Specification for Airsoft Guns](#)

2.2 *ANSI Standards:*³

[Z80.3 Requirements for Nonprescription Sunglasses and Fashion Eyewear](#)

[Z87.1 Practice for Occupational and Educational Eye and Face Protectors](#)

2.3 *CSA Standard:*⁴

[CSA Z262.6-02 Specifications for Facially Featured Headforms](#)

[CSA Z262.6-14 Specifications for Facially Featured Head Forms](#)

2.4 *EN Standard:*⁵

[EN 168 Personal Eye Protection—Non-Optical Test Method—Section 17 Headforms](#)

¹ This specification is under the jurisdiction of ASTM Committee F08 on Sports Equipment, Playing Surfaces, and Facilities and is the direct responsibility of Subcommittee F08.57 on Eye Safety for Sports.

Current edition approved April 1, 2018; April 1, 2019. Published April 2018; April 2019. Originally approved in 2014. Last previous edition approved in 2016 as F2879 – 16; F2879 – 18. DOI: 10.1520/F2879-18.10.1520/F2879-19.

² For referenced ASTM standards, visit the ASTM website, www.astm.org, or contact ASTM Customer Service at service@astm.org. For *Annual Book of ASTM Standards* volume information, refer to the standard's Document Summary page on the ASTM website.

³ Available from American National Standards Institute (ANSI), 25 W. 43rd St., 4th Floor, New York, NY 10036, <http://www.ansi.org>.

⁴ Available from Canadian Standards Association (CSA), 5060 Spectrum Way, Mississauga, ON L4W 5N6, Canada, <http://www.csa.ca>.

⁵ Available from European Committee for Standardization (CEN), Avenue Marnix 17, B-1000, Brussels, Belgium, <http://www.cen.eu>.

3. Terminology

3.1 Definitions of Terms Specific to This Standard:

- 3.1.1 *adnexa*, *n*—adjunct parts of the eye, including the orbit, orbital contents, eyelids, and the lacrimal apparatus.
- 3.1.2 *airsoft field*, *n*—area where participants actively target and shoot each other with airsoft projectiles using airsoft guns.
- 3.1.3 *airsoft gun*, *n*—device specifically designed to expel airsoft projectiles as the result of the release of energy by compressed air, compressed carbon dioxide (CO₂), mechanical springs, battery, or a combination thereof as defined in Specification **F2748**.
- 3.1.4 *airsoft projectile*, *n*—6 mm projectiles used with an airsoft gun which is defined in Specification **F2679**.
- 3.1.5 *astigmatism*, *n*—condition in a lens that creates two axially separated line foci of each object point, the lines being mutually perpendicular; in other words, the lens has two different refractive powers in meridians that are 90° apart.
- 3.1.6 *base-in*, *adj*—relating to the type of prism imbalance that tends to cause parallel rays of light passing through a EPD, spaced apart by the interpupillary distance, to converge.
- 3.1.7 *base-out*, *adj*—relating to the type of prism imbalance that tends to cause parallel rays of light passing through an EPD, spaced apart by the interpupillary distance, to diverge.
- 3.1.8 *binocular*, *adj*—relating to the field of view that is shared by both eyes simultaneously.
- 3.1.9 *central viewing zone*, *n*—that part of a lens that has its center in line with the wearer's line of sight when looking straight ahead.

3.1.9.1 Discussion—

The zone is circular in shape. For the purpose of this specification, it shall be considered to be 38 mm in diameter. The center of the central viewing zone shall be the point of intersection of the line of sight with the lens as mounted on the headform, as specified by the manufacturer.

- 3.1.10 *corneal apex*, *n*—the most anterior point of the cornea when the eye is in the primary position.
- 3.1.11 *cleanable*, *adv*—ability of an EPD to be made readily free of dirt or grime without being damaged during an appropriate cleaning process, such as the use of soap and water.
- 3.1.12 *definition, optical*, *n*—characteristic of a lens that allows separate distinct points in close proximity to be discerned when looking through the lens.
- 3.1.13 *dislodgement*, *n*—relating to the movement or shifting during impact testing as described in section 8 that would result in a gap between the lens and frame that did not exist prior to the testing of more than 1.0 mm or the breaking free of any EPD components within the interior chamber of the EPD.
- 3.1.14 *eye*, *n*—relating to the eye of the headform or the eye of a person wearing an EPD or that part of an EPD through which a wearer's eye would normally look.
- 3.1.15 *eye of the headform*, *n*—all structures contained within the orbital rim of the headform.
- 3.1.16 *eye protective device (EPD)*, *n*—device that provides protection to the wearer's eyes against specific hazards encountered in sports.
- 3.1.17 *fracture*, *n*—any breach, rupture, or visible crack in the lens.
- 3.1.18 *haze*, *n*—fraction of the total transmitted light from a normally incident beam that is not transmitted in a focused condition but scattered by inclusions or surface defects.

3.1.18.1 Discussion—

Excessive haze will reduce contrast and visibility.

3.1.19 *headform*, *n*—as utilized within this standard for the as-worn assessment of EPDs, key dimensions of which are as provided in ~~CSA Z262.6-02~~ or ~~EN 168:Z262.6-02~~, EN 168, or CSA Z262.6-14 except with an adjusted durometer (hardness) of 50 ± 5.5 Shore A.

3.1.20 *lens*, *n*—transparent part or parts of an EPD through which the wearer normally sees.

3.1.20.1 Discussion—

The most common configurations for lenses are single pane and thermal. Thermal lenses are constructed with multiple panes providing a thermal barrier to reduce the effects of fogging. Some lenses may be treated with chemical solutions to reduce fogging.

3.1.21 *lens retention component(s), n*—components, separate from the lens, that are designed to retain the lens in the frame or body of the EPD.

3.1.22 *luminous transmittance, n*—function of the spectral transmittance of the lens weighted by the corresponding ordinates of the photopic luminous efficiency distribution of the CIE (1931) standard colorimetric observer and by the spectral intensity of standard Illumination C (see ANSI Z80.3).

3.1.23 *orbital area, n*—area contained in a circle $r = 20$ mm centered on the pupil of the headform.

3.1.24 *power imbalance, n*—condition that exists when the refractive power created by the right lens of the EPD is different from that of the left lens.

3.1.25 *prism, n*—angular deviation of a ray of light as it passes through a lens resulting from the angle at which the ray strikes each surface of the lens and the index of refraction of the material from which it is made.

3.1.26 *prism imbalance, n*—

3.1.26.1 *horizontal imbalance, n*—difference in prismatic deviation of incident parallel light beams on the two eyes of an EPD in the horizontal meridian (see *base-in* and *base-out*).

3.1.26.2 *vertical imbalance, n*—difference in prismatic deviation between parallel light beams incident on the two eyes of an EPD in the vertical meridian.

3.1.27 *refractive power, n*—focusing effect of a lens expressed in diopters.

3.1.28 *spherical power, n*—average of the maximum meridional astigmatic power and the minimum meridional astigmatic power of a lens.

3.1.29 *tactical sport, n*—within the context of this standard an activity in which participants actively target and shoot at each other with airsoft projectiles using an airsoft gun.

4. Performance Requirements

4.1 Optical Requirements:

4.1.1 *Field of View*—When tested in accordance with 7.1, the EPD—EPD, without any accessories such as a sun visor installed, shall have a field of view equal to or exceeding the following:

4.1.1.1 *Temporal field*—50°.

4.1.1.2 *Nasal field*—30°.

4.1.1.3 *Superior field*—30°.

4.1.1.4 *Inferior field*—30°.

4.1.2 *Refractive Tolerances*—When tested in accordance with 7.6, the spherical power shall not be less than -0.12 diopters and shall not exceed $+0.12$ diopters.

4.1.3 *Astigmatism*—When tested in accordance with 7.6, the astigmatism shall not exceed 0.25 diopters.

4.1.4 *Power Imbalance*—When tested in accordance with 7.6, the power imbalance in corresponding meridians between the two eyes for straight ahead seeing shall not exceed 0.18 diopters.

4.1.5 *Prism*—When tested in accordance with 7.4 or 7.8, the primary viewing position of either eye of a shield shall not exceed 0.5 prism diopters.

4.1.6 *Prism Imbalance*—When tested in accordance with 7.4 or 7.8, the prism imbalance shall meet the following criteria:

4.1.6.1 *Vertical imbalance*—It shall not exceed $+0.25$ diopters.

4.1.6.2 *Horizontal imbalances*—Negative values (base-in) shall not be less than -0.25 prism diopters, and positive values (base-out) shall not be more than $+1.0$ prism diopters.

4.1.7 *Luminous Transmittance*—When tested in accordance with 7.3, the luminous transmittance shall not be less than 60 % for clear lenses and not less than 17 % for tinted lenses unless labeled very dark in which case the minimum transmittance shall be no less than 8 %.

4.1.8 *Haze*—When tested in accordance with 7.5, the haze of the EPD shall not exceed 3 %.

4.1.9 *Optical Quality*—Within the central viewing zone, striae, warpage, surface ripples, or other defects that are apparent under the optical inspection test conditions of 7.2 shall be considered a failure. An exception is when small specks or inclusions, which are not seen when the lens is held close to the eye in the as-worn position, shall not be a cause of rejection.

4.1.10 *Physical Lens Defects*—Within the central viewing zone, pits, scratches, grayness, bubbles, cracks, watermarks, or other defects that are apparent under the visible inspection test conditions of 7.7 shall be considered a failure. An exception is small specks or inclusions, which are not seen when the lens is held close to the eye in the as-worn position, shall not be cause of rejection.

4.2 Mechanical Requirements:

4.2.1 When tested in accordance with 8.2.3 (high-velocity impact test):

4.2.1.1 Any visible damage of the lens or frame that results in any component of the EPD to become dislodged inside the interior chamber of the EPD or the entry of an airsoft projectile as defined in 3.1.4 constitutes a failure,

4.2.1.2 No contact by components of the EPD with the orbital area of the headform shall be permitted,

- 4.2.1.3 Any dislodging of the lens from the frame constitutes a failure,
- 4.2.1.4 Any dislodging of a lens retention component from the lens constitutes a failure, and
- 4.2.1.5 Any opening in the frame or lens of EPD that would permit contact of a 4.5 mm diameter probe ± 0.1 mm to the orbital area of the headform constitutes a failure. No significant force is to be applied to force the probe through any opening.
- 4.2.2 When tested in accordance with 8.2.4 (lens retention test):
 - 4.2.2.1 Any visible fracture of the lens or frame constitutes a failure,
 - 4.2.2.2 No contact by components of the EPD or airsoft projectile as defined in 3.1.4 within the orbital area of the headform shall be permitted,
 - 4.2.2.3 Any dislodging of the lens from the frame constitutes a failure,
 - 4.2.2.4 Any dislodging of a lens retention component from the lens constitutes a failure, and
 - 4.2.2.5 Any opening in the frame or lens of EPD that would permit direct contact of a 4.5 mm diameter probe ± 0.1 mm to the orbital area of the headform constitutes a failure. No significant force is to be applied to force the probe through any opening.
- 4.3 *Ventilation Openings Requirements*—Any ventilation opening in the EPD that would permit direct contact of a 4.5 mm diameter probe ± 0.1 mm to the orbital area of the headform constitutes a failure. No significant force is to be applied to force the probe through any opening. Any evaluation must be conducted with the EPD installed in accordance with the manufactures instruction manual on the headform as specified in section 6.4.

5. General Requirements

5.1 *Materials of Construction:*

- 5.1.1 The manufacturer is responsible that the materials selected meet the following criteria and may confirm compliance by providing the testing laboratory with a declaration letter regarding the suitability of the materials for inclusion with the final test report:
 - 5.1.2 Materials exposed to sunlight shall not undergo significant loss of physical properties.
 - 5.1.3 Materials coming into contact with the wearer's face shall not be of a type known to cause skin irritation.
 - 5.1.4 Materials coming into contact with the wearer's face shall not undergo significant loss of strength, flexibility, or other physical change as a result of perspiration, oil, or grease from the wearer's skin and hair.

5.2 *Openings:*

- 5.2.1 All openings in the EPD, such as those for ventilation, shall not allow the passage of a 4.5 mm diameter probe ± 0.1 mm. In cases where a foam or air permeable barrier is used to cover ventilation openings of the EPD, the underlying structure (under the foam or air permeable barrier) shall not allow the passage of a 4.5 mm diameter probe ± 0.1 mm. This requires the openings in the structure under the foam to have no opening which will allow the passage of the probe, with or without the foam in place.
- 5.2.2 All opening for ventilation on the EPD shall be inspected by the method described in 4.3.

6. Sample Preparation

6.1 *Eye Protective Devices:*

- 6.1.1 Only new and complete EPDs as offered for sale shall be tested.
- 6.1.2 A minimum of nine EPDs will be required for the tests.
- 6.1.3 The EPD and the airsoft projectiles shall be conditioned for a minimum of 4 h at the specified temperature before each test.

6.2 *Test Temperatures:*

- 6.2.1 *Cold Test*, $-12.2 \pm 2^\circ\text{C}$.
- 6.2.2 *Ambient Temperature*, $23 \pm 2^\circ\text{C}$.
- 6.2.3 *Hot Test*, $37.8 \pm 2^\circ\text{C}$.

6.3 *Airsoft Projectiles*—Airsoft projectiles used in the tests contained within this specification shall be in conformity with Specification F2679 with a stated weight of 0.20 and 0.25 g. A manufacturer's declaration of compliance with the standard will be considered acceptable verification.

6.4 *Headform*—The manufacturer shall normally specify to the testing facility the type and size of headform to be used for testing within this standard. This selection will be based upon the design and size of the EPD. In the case where the manufacturer does not specify a specific headform or size the CSA Z262.6-02 Adult Male headform will be considered the default choice. testing lab may select the headform based on the best fit as would normally be worn by the user and secured in accordance with the manufacturer's instructions.

TEST METHODS

7. Optical Test Methods

7.1 *Field of View (Angle of Vision):*

7.1.1 *Purpose*—This test method is intended to determine the relative unobstructed angle visually available to the user. With the EPD mounted on the standard headform, the corneal apex of the cornea shall be visible to an observer when sighted from the required field angles in accordance with 4.1.1. Any sighting method may be used. Paragraphs 7.1.2 – 7.1.4 give one method.

7.1.2 *Apparatus*—The concept is to mount a headform per as specified in 6.4, size specified by the manufacturer or chosen by the test laboratory, in a gimbal. Any gimbal that is sufficiently large and sturdy and properly inscribed with horizontal and vertical protractor markings is acceptable. Figs. 1-3 show front and side vertical schematic views of a wooden gimbal that can be constructed with simple tools. Item A is the base and support for horizontal rotation. A protractor shaft should be marked on the base with its center coincident with the axis of rotation. Base A shaft should protrude forward to allow for the protractor markings. These indicate the position of B. Item B comprises the main carriage of the gimbal. Item C comprises the vertically rotating member. Sections CR and CL are the right and left vertical supports. Fig. 2 shows the horizontal view. A window in the left of the vertical B support makes the protractor markings on section CL visible for accurate setting. Section CL can be pie-shaped, providing that a 60° angle can be read. The markings shall be made every 5° and marked every ten. A set screw should be threaded into the B section or a 1/4-20 nut can be inlaid if section B is wooden. Ensure that 1/4-20 thumb screws are available readily for use as the set screw. The location of the standard head should be planned to obtain a good balance for vertical rotations. The horizontal rotation axis shall be in the plane of the corneas. The axis themselves can be 12-mm dowels or 6-mm metal rods. Fig. 3 shows the location of the pivots for their respective rotations. Fig. 4 shows an example of a test setup. The total path from gimbal to the eye, camera, or light source shall be at least 7.31 m. Using a mirror facilitates adjusting the gimbal while observing the position of the corneas in the EPD. A low-power telescope or simply a monocular eye-locating ring or washer can be substituted for the video camera. The corneas shall be painted white or covered with white or reflecting tape in the form of an 8-mm disk. A high-level ambient light is desirable. Visual optics may be replaced with photo detectors in the corneas having separate readout means for the two eyes. A strong light source would replace the video camera, in which case, a low-level of ambient light is desirable. A collimating lens would increase the signal-to-noise ratio of the photodetectors. The setup as indicated in the drawing introduces a horizontal angle of error of -0.2° and a vertical angle of error of approximately -0.6° at 60°. The location of the vertical angle of tip is centered in the headform to help balance the gimbal. These errors can be accounted for in the decision process. A longer path between the input and output devices will decrease the errors proportionately.

7.1.3 *Test Procedure*—Mount the EPD to be tested on the headform in the intended wearing position. Set the gimbal in the straight-ahead position and verify the visibility of the metered response of the two eyes. The gimbal then is rotated to determine the horizontal and vertical extreme angles of view in all four directions along which the appropriate corneas can be seen monocularly.

7.1.4 *Report*—Record and report the maximum angles of view in all four directions.

7.2 *Optical Quality*—Localized power errors or aberrations that are detected by the visual inspection procedure of 7.2.1 are permissible if no measurable or gross foci meter or telescope target distortion or blur is found when the localized area is examined with an instrument as indicated in 7.2.2.

7.2.1 *Inspection Procedure*—One method of optical inspection is to view a high-contrast grid pattern of dark and white lines through the lens, scanning it area by area and moving it about. The grid pattern shall be at least 45 by 45 cm and constructed of high-contrast black lines on a white background (the white separations being equal to the black lines, both being approximately 6 mm wide). The target shall be at least 1.8 to 2.5 m from the observer, and the lens shall be held at least 45 to 60 cm from the eye. Any ripples in the lens detected by this test method shall be further examined in accordance with 7.2.2.

7.2.2 The referee method of detecting optical defects and local aberrations is to scan the central viewing zone, especially areas of suspicion arising from the visual test of 7.2.1. The lens of EPD shall be scanned with a precision foci meter or an 8 to 10x

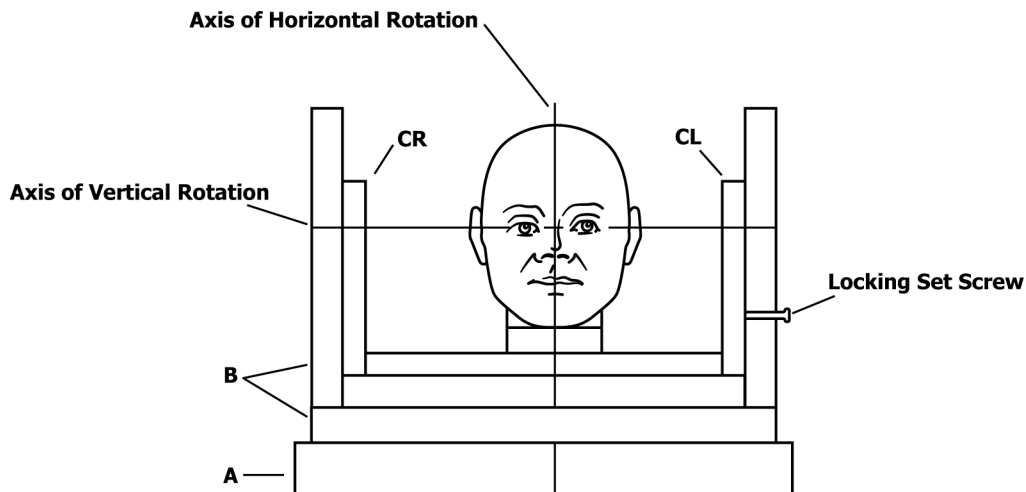

FIG. 1 Schematic of Gimbal for Supporting Standard Head

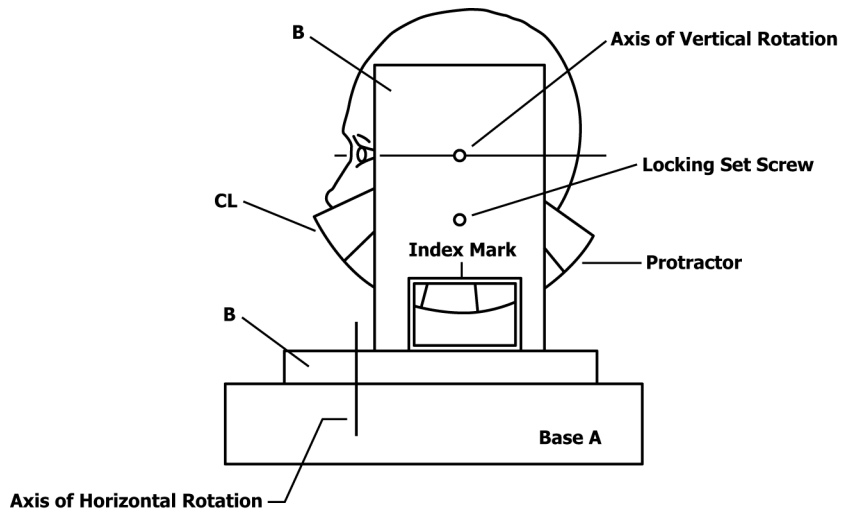

FIG. 2 Side View of Gimbal

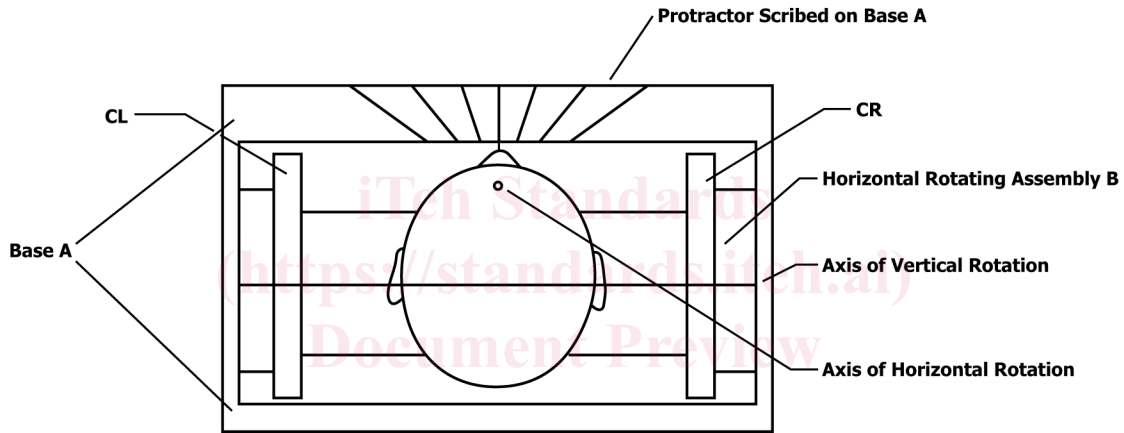

FIG. 3 Top View Showing Base for Horizontal Rotation

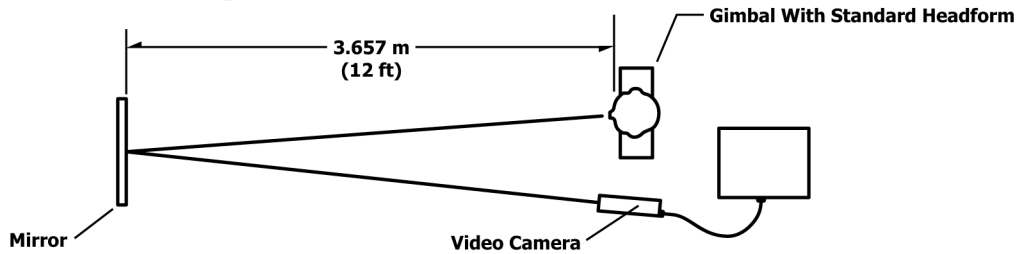

FIG. 4 Bench-Top Field-of-View Setup

telescope using the targets and arrangements described in 7.6.2 – 7.6.3.2. The aperture shall be 5 to 7 mm for this examination. Areas outside the central viewing zone or within 6 mm of the edge need not be tested. When the central viewing area is scanned, there shall be no sudden jump, doubling, or blurring of the image greater than 0.08-diopters change in power. Gradual variations in the central viewing zone shall be within the power imbalance tolerances. An optical foci meter with electronic readout repeatable to 0.02 diopters is a satisfactory alternate method. These scanning procedures may be made by scanning across the lens surface not necessarily in the “as-worn” mode.

7.3 *Luminous Transmittance*—Use a suitable photometer or other device comprised of a light source of CIE Illuminant C at 6774K color temperature and a photometric probe and meter capable of reading transmission in percent over a range from 1 to 100 %. Use a suitable enclosure to block against stray light and contain the test samples. Following the manufacturer’s instruction for the use of the instrument, measure the specimen for percent transmittance within each of the two central viewing zones. The measured values shall meet the established criteria for the device. A spectrophotometer, followed by appropriate photometric calculation, also may be used.