



Designation: **F3348 – 18 F3348 – 19**

Standard Specification for Plastic Press Insert Fittings with Factory Assembled Stainless Steel Press Sleeve for SDR9 Cross-linked Polyethylene (PEX) Tubing¹

This standard is issued under the fixed designation F3348; the number immediately following the designation indicates the year of original adoption or, in the case of revision, the year of last revision. A number in parentheses indicates the year of last reappraisal. A superscript epsilon (ϵ) indicates an editorial change since the last revision or reappraisal.

1. Scope—Scope*

1.1 This specification covers plastic press insert fittings with factory assembled stainless steel press sleeves incorporating 3 view holes and a tool locator ~~ring~~ ring. These fittings are for use with cross-linked polyethylene (PEX) tubing in nominal sizes $\frac{3}{8}$, $\frac{1}{2}$, $\frac{3}{4}$, 1, $1\frac{1}{4}$, $1\frac{1}{2}$, and 2 that meet the requirements for Specification F876 or F3253. These fittings are intended for use in 100 psi (690 kPa) cold- and hot-water distribution systems operating at temperatures up to and including 180 °F (82 °C). Included are the requirements for material, molded part properties, performance, workmanship, dimensions, and markings to be used on the fittings and sleeves. The components covered by this specification are intended for use in residential and commercial, hot and cold, potable water distribution systems as well as sealed central heating, including under-floor heating/cooling systems, and residential fire sprinkler systems.

1.2 *Units*—The values stated in inch-pound units are to be regarded as standard. The values given in parentheses are mathematical conversions to SI units that are provided for information only and are not considered standard.

1.3 *This standard does not purport to address all of the safety concerns, if any, associated with its use. It is the responsibility of the user of this standard to establish appropriate safety, health, and environmental practices and determine the applicability of regulatory limitations prior to use.*

1.4 *This international standard was developed in accordance with internationally recognized principles on standardization established in the Decision on Principles for the Development of International Standards, Guides and Recommendations issued by the World Trade Organization Technical Barriers to Trade (TBT) Committee.*

2. Referenced Documents

2.1 ASTM Standards:²

- A269/A269M Specification for Seamless and Welded Austenitic Stainless Steel Tubing for General Service
- D1600 Terminology for Abbreviated Terms Relating to Plastics
- D2122 Test Method for Determining Dimensions of Thermoplastic Pipe and Fittings
- D6394 Specification for Sulfone Plastics (SP)
- E92 Test Methods for Vickers Hardness and Knoop Hardness of Metallic Materials
- F412 Terminology Relating to Plastic Piping Systems
- F876 Specification for Crosslinked Polyethylene (PEX) Tubing
- F877 Specification for Crosslinked Polyethylene (PEX) Hot- and Cold-Water Distribution Systems
- F3253 Specification for Crosslinked Polyethylene (PEX) Tubing with Oxygen Barrier for Hot- and Cold-Water Hydronic Distribution Systems

2.2 NSF/ANSI Standards:³

- Standard 14 Plastic Piping Components and Related Materials
- Standard 61 Drinking Water System Components-Health Effects
- Standard 372 Drinking Water System Components-Lead Content

¹ This test method is under the jurisdiction of ASTM Committee F17 on Plastic Piping Systems and is the direct responsibility of Subcommittee F17.10 on Fittings. Current edition approved Nov. 1, 2018/April 1, 2019. Published December 2018/April 2019. Originally approved in 2018. Last previous edition approved in 2018 as F3348-18. DOI: 10.1520/F3348-18/10.1520/F3348-19

² For referenced ASTM standards, visit the ASTM website, www.astm.org, or contact ASTM Customer Service at service@astm.org. For *Annual Book of ASTM Standards* volume information, refer to the standard's Document Summary page on the ASTM website.

³ Available from NSF International, P.O. Box 130140, 789 N. Dixboro Rd., Ann Arbor, MI 48105, http://www.nsf.org.

*A Summary of Changes section appears at the end of this standard

2.3 PPI Standards:⁴

PPI TR-3 Policies and Procedures for Developing Hydrostatic Design Basis (HDB), Pressure Design Basis (PDB), Strength Design Basis (SDB), and Minimum Required Strength (MRS) Ratings for Thermoplastic Piping Materials or Pipe

3. Terminology

3.1 *Definitions*—Unless otherwise specified, definitions, abbreviations and initialisms are in accordance with Terminology F412 and Terminology D1600.

3.2 Definitions:

3.2.1 *plastic press insert fitting, n*—A type of fitting joint that attaches directly to the plastic tubing piping component that is pushed into the open end of the plastic tubing and attaches by mechanically pressing and deforming an outer stainless steel sleeve over the plastic tubing which then compresses and displaces plastic onto the insert fitting's barbs creating a seal and a permanent connection outside diameter of the plastic tubing. The seal is realized between the outer diameter of the insert fitting and the inner diameter of the plastic tubing. Mechanical pressing is achieved by the use of press tool.

3.2.2 *press sleeve, n*—Cylindrical shaped stainless steel ring which is compressed with a pressing tool while located over the PEX tubing securing it permanently to the underlying insert fitting.

3.2.3 *press tool, n*—A device by which the stainless sleeve is compressed by a forming die that is radially closed down on the press sleeve by either hand powered or electro-mechanical pressing action.

4. Classification

4.1 This specification governs one class of fittings and stainless steel press sleeve suitable for use PEX tubing that meets either the requirements of Specifications F876 or F3253.

5. Materials and Manufacture

5.1 *Material*—Fittings shall be molded from sulfone plastic (SP) as specified in Specification D6394. The material shall be unreinforced polyphenylsulfone blends (group 03, Class 1, grade 2) or reworked plastic in accordance with 5.1.1.

NOTE 1—Since fittings specified by this standard will be used in hot-and-cold water plumbing systems, a material used to manufacture fittings in accordance with this specification must demonstrate qualities consistent with that application in addition to the performance requirements of this specification. Those qualifying characteristics include, but are not limited to, an established hydrostatic design basis (HDB) or stress design basis (SDB) in accordance with PPI TR-3 or similar rating and a demonstration of resistance to the long-term effects of those chemicals normally found in potable water at the maximum temperature stated in this specification.

5.1.1 *Rework Material*—Clean rework material of the same commercial designation, generated from the manufacturer's own production may be used by the same manufacturer, provided the fittings meet all of the requirements of this specification. Reworked material shall not be introduced at a ratio exceeding 25 %.

<https://standards.iteh.ai/catalog/standards/sist/5c592565-004f-499c-bec7-faed1ba26d08/astm-f3348-19>

TABLE 1 Polymer Insert Dimensions and Tolerances^C

NTS	A ^A		B ^E		C ^D	D		E		F	H	r	±
	in.	± in.	in.	± in.		in.	± in.	in.	± in.				
3/8	0.340	0.004	0.201	0.012	0° - 10°	0.307	0.012	0.344	0.008	15° - 25°	0.091	0.012	0.004
1/2	0.469	0.004	0.311	0.012	0° - 10°	0.437	0.012	0.344	0.008	15° - 25°	0.187	0.012	0.004
3/4	0.658	0.004	0.480	0.012	0° - 10°	0.626	0.012	0.344	0.008	15° - 25°	0.187	0.012	0.004
1	0.852	0.004	0.661	0.012	0° - 10°	0.823	0.012	0.472	0.008	N/A	N/A	0.051	0.004
1 1/4	1.034	0.004	0.807	0.012	0° - 10°	1.004	0.012	0.689	0.008	N/A	N/A	0.079	0.004
1 1/2	1.223	0.004	0.941	0.012	0° - 10°	1.193	0.012	0.689	0.008	N/A	N/A	0.079	0.004
2	1.579	0.004	1.244	0.012	0° - 10°	1.543	0.012	0.677	0.008	N/A	N/A	0.079	0.004

NTS	J		G		K	L		I	T ^B		R	±	X
	in.	± in.	in.	± in.		in.	± in.		Min. in.	in.			
3/8	0.110	0.008	0.087	0.008	0.378	0.016	0.512	0.043	0.008	0.047	0.008	0.004	35° - 45°
1/2	0.110	0.008	0.087	0.008	0.378	0.016	0.512	0.043	0.008	0.059	0.008	0.004	35° - 45°
3/4	0.110	0.008	0.087	0.008	0.378	0.016	0.512	0.043	0.008	0.067	0.008	0.004	35° - 45°
1	0.118	0.008	0.118	0.008	0.500	0.016	0.669	0.059	0.008	0.075	0.008	0.004	35° - 45°
1 1/4	0.126	0.008	0.165	0.008	0.720	0.016	0.906	0.083	0.008	0.091	0.008	0.004	35° - 45°
1 1/2	0.126	0.008	0.165	0.008	0.720	0.016	0.906	0.083	0.008	0.118	0.008	0.004	35° - 45°
2	0.126	0.008	0.165	0.008	0.720	0.016	0.906	0.083	0.008	0.142	0.008	0.004	35° - 45°

^A Rib outside diameter shall be measured individually.

^B Applies to entire fitting (not just to insert area), except for the area identified within the "H" dimension.

^C Directional fittings shall be designed with sufficient overall dimensions to allow proper use of press tool without interference with previously completed press on the same fitting.

^D Lead chamfer area is not considered a rib.

^E ID "B" shall be maintained through the insert length "L".

⁴ Available from Plastics Pipe Institute (PPI), 105 Decker Court, Suite 825, Irving, TX 75062, <http://www.plasticpipe.org>.

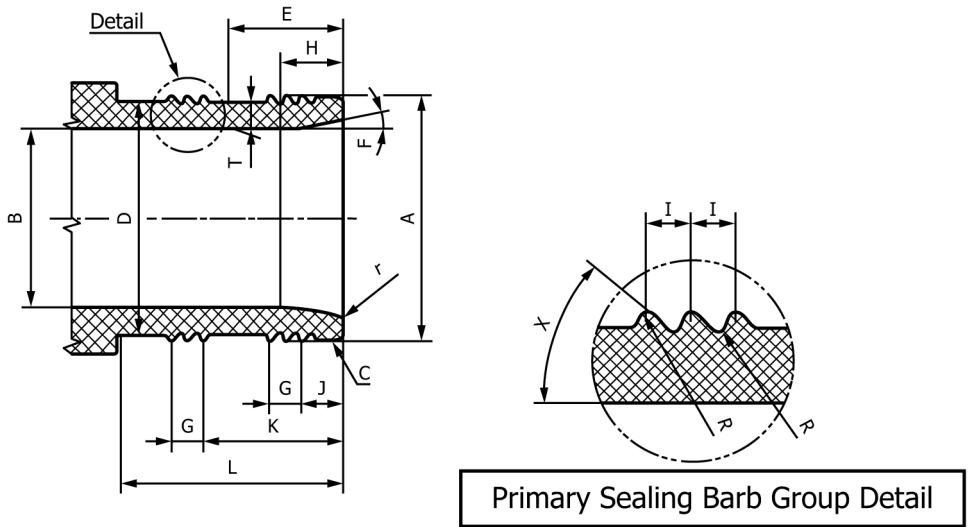

FIG. 1 Polymer Insert Dimensions

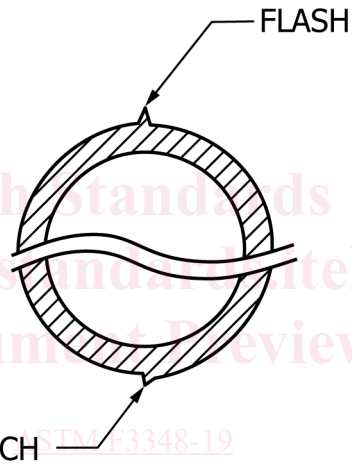

FIG. 1A Flash and Mismatch created by Imperfection in Die Half Interfaces^F

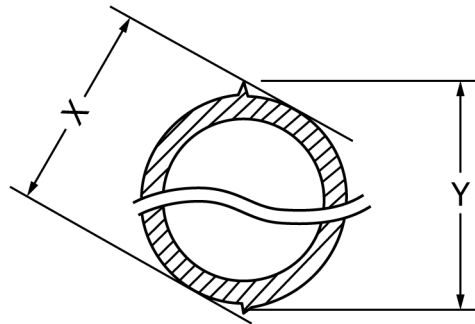

FIG. 1B Total Flash and Mismatch^F

FIG. 1

^FFig 1A, Fig.1A and Fig.1B are a graphic definition of flash and mismatch created by imperfection in die half interfaces. See 7.3. The total mismatch is assumed to be the difference between "X" and "Y." These dimensions may be measured with appropriate calipers or micrometers.