



Designation: **C1485 – 13 C1485 – 19**

## Standard Test Method for Critical Radiant Flux of Exposed Attic Floor Insulation Using an Electric Radiant Heat Energy Source<sup>1</sup>

This standard is issued under the fixed designation C1485; the number immediately following the designation indicates the year of original adoption or, in the case of revision, the year of last revision. A number in parentheses indicates the year of last reapproval. A superscript epsilon ( $\epsilon$ ) indicates an editorial change since the last revision or reapproval.

### 1. Scope

1.1 This test method covers a procedure for measuring the critical radiant flux of exposed attic floor insulation subjected to a flaming ignition source in a graded radiant heat energy environment inside a test chamber. The test specimen can be any attic floor insulation. This test method is not applicable to those insulations that melt or shrink away when exposed to the radiant heat energy environment or the ignition source.

1.2 This test method measures the critical radiant flux at the farthest point to which the flame advances. It provides a means for relative classification of a fire test response standard for exposed attic floor insulation. The imposed radiant flux simulation levels of thermal radiation are likely to impinge on the surface of exposed attic insulation from roof assemblies heated by the sun and by heat or flames of an incidental fire which has the potential to involve an attic space. This test method is intended to simulate an important element of fire exposure that has the potential to develop in open attics, but is not intended for use in describing flame spread behavior of insulation installed other than on an attic floor.

1.3 The values stated in SI units are to be regarded as standard. The values given in parentheses are for information only.

1.4 This standard is used to measure and describe the response of materials, products, or assemblies to heat and flame under controlled conditions, but does not by itself incorporate all factors required for fire hazard or fire risk assessment of the material, products, or assemblies under actual fire conditions.

1.5 **Warning**—Fire testing is inherently hazardous. Adequate safeguards for personnel and property shall be employed in conducting these tests.

1.6 *This standard does not purport to address all of the safety concerns, if any, associated with its use. It is the responsibility of the user of this standard to establish appropriate safety, health, and environmental practices and determine the applicability of regulatory limitations prior to use.*

1.7 *This international standard was developed in accordance with internationally recognized principles on standardization established in the Decision on Principles for the Development of International Standards, Guides and Recommendations issued by the World Trade Organization Technical Barriers to Trade (TBT) Committee.*

### 2. Referenced Documents

2.1 *ASTM Standards:*<sup>2</sup>

[C168 Terminology Relating to Thermal Insulation](#)

[E691 Practice for Conducting an Interlaboratory Study to Determine the Precision of a Test Method](#)

2.2 *ASTM Adjuncts:*

CRF (Critical Radiant Flux) Calibration Form<sup>3</sup>

### 3. Terminology

3.1 *Definitions:*

3.1.1 For definitions of terms used in this specification, see Terminology [C168](#).

<sup>1</sup> This test method is under the jurisdiction of ASTM Committee [C16](#) on Thermal Insulation and is the direct responsibility of Subcommittee [C16.31](#) on Chemical and Physical Properties.

Current edition approved ~~March 1, 2013~~ April 1, 2019. Published ~~March 2013~~ April 2019. Originally approved in 2001. Last previous edition approved in ~~2006~~ 2013 as [C1485-06](#). [C1485 – 13](#). DOI: [10.1520/C1485-13](#). [10.1520/C1485-19](#).

<sup>2</sup> For referenced ASTM standards, visit the ASTM website, [www.astm.org](#), or contact ASTM Customer Service at [service@astm.org](#). For *Annual Book of ASTM Standards* volume information, refer to the standard's Document Summary page on the ASTM website.

<sup>3</sup> Available from ASTM International Headquarters. Order Adjunct No. [ADJC1485](#). Original adjunct produced in 2006.

3.2 *Definitions of Terms Specific to This Standard:*

3.2.1 *critical radiant flux (CRF)*—the level of incident radiant heat energy on the attic floor insulation system at the most distant flame-out point in  $W/cm^2$  ( $Btu/ft^2 \cdot s$ ).

3.2.2 *flux profile*—the curve relating incident radiant heat energy on the specimen plane to distance from the point of initiation of flaming ignition, that is, 0.0 cm. (0.0 in.).

3.2.3 *graded radiant energy*—the heating element is placed on an angled plain.

3.2.4 *total flux meter*—the instrument used to measure the level of radiant heat energy incident on the specimen plane at a given point.

3.2.5 *screed*—gently remove the excess material using a metal straight edge to leave a uniform surface on the insulation flush with the top of the container.

4. Summary of Test Method

4.1 A horizontally mounted insulation specimen is exposed to the heat from an electric radiant heat energy panel located above and inclined at 30° to the specimen. After a short preheat, the hottest end of the specimen is ignited with a small flame. The distance to the farthest advance of flaming is measured, converted to watts per square centimeter from a previously prepared graph of the radiant flux profile, and reported as the critical radiant flux.

5. Significance and Use

5.1 This test method is designed to provide a basis for estimating one aspect of the fire exposure behavior of exposed insulation installed on the floor of an open attic. The test environment is intended to simulate attic floor exposure to radiant heat conditions. Radiant heat has been observed and defined in full-scale attic experiments.

6. Apparatus

6.1 *Radiant Panel Test Chamber:*

6.1.1 *Cabinet*, consists of an angle aluminum frame faced on four sides with cement fiber board or ceramic tile backer board 6 mm (1/4 in.) and approximate overall dimensions of 80 cm (32 in.) high by 71 cm (28 in.) long by 30 cm (12 in.) deep with a viewing window along the front side and a vertical cement fiber board sliding on the right-hand end.

6.1.2 *Specimen Holder*, an open-top 0.16 mm (22–26 U.S. standard gage) thick stainless steel sheet with the vertical edges of the tray overlapped, not to exceed 7 mm (0.273 in.) in seam width, and joined to be watertight. ~~Tray with a watertight tray with an outside dimension measuring exactly 60 cm (24 in.)~~  $60 \pm 0.2$  cm long, by 15 cm (6 in.) wide by 5.0 cm (2 in.) deep.

6.1.3 *Radiant Heat Energy Source*, consists of a 110 V, 650 W, 1.3 cm (1/2 in.) diameter heating element that is 35 cm (14 in.) long, mounted in a stainless steel reflector with overall dimensions of 49 cm (19.5 in.) long by 9.5 cm (3.75 in.) wide. The heater is mounted inside the cabinet at a 30° angle to the horizontal rising away from the door.

6.1.4 *Dial Temperature Gage*, shall be a panel mount type attached onto the front of the cabinet to monitor the interior cabinet temperature and placed in the back upper left quadrant at 7.5 cm (3 in.) from the top and 20 cm (8 in.) from the back. The gauge shall have a range of 0 to 121°C (32 to 250°F) graduated in 2°C (2°F) increments.

6.1.5 *Exhaust Fan*, shall be mounted into the top of the cabinet at the opposite end from the door, unobstructed air flow out. The fan is 76 mm (3 in.) in diameter, 0.76 cmm (30 cfm), operating on 120 V.

6.1.6 *Control Switches*, two toggle switches are mounted on the top of the cabinet adjacent to the fan and are used to energize the exhaust fan and radiant energy source. Household switches have worked well.

6.1.7 *Environment*—The radiant panel test chamber employed for this test shall be located in a draft-protected area and maintained at  $21 \pm 2^\circ C$  ( $70 \pm 4^\circ F$ ) and a relative humidity of  $50 \pm 20 \%$ .

6.1.8 *Power Source*, a device shall be incorporated that maintains or monitors a reliable  $115 \pm 5$  AC volts.

6.1.9 *Hardware Description for Electric Radiant Panel:*

6.1.9.1 The following are the ~~components~~components of the radiant panel test chamber described in Fig. 1. The various dimensions are described in 6.1.10

1. Toggle switch
2. Exhaust fan
3. Thermometer
4. Aluminum flat welded on under side of angle for rod support
5. 1 cm (3/8 in.) rod (ready bolt)
6. Electric heat element (650 watt chromalox)
7. Aluminum angle 2.5 cm (1 in.) (tray slide rails)
8. Aluminum angle 4 cm (1.5 in.) (all framing)
9. Lock nuts for rods
10. Viewing glass 6 mm (1/4 in.)
11. Cement board or ceramic tile backerboard 6 mm (1/4 in.)
12. Flat aluminum with holes for rod and heat element twisted to fit

6.1.10 *Dimensions of Electric Radiant Panel:*

6.1.10.1 The following are the dimensions of the items shown in Fig. 1.

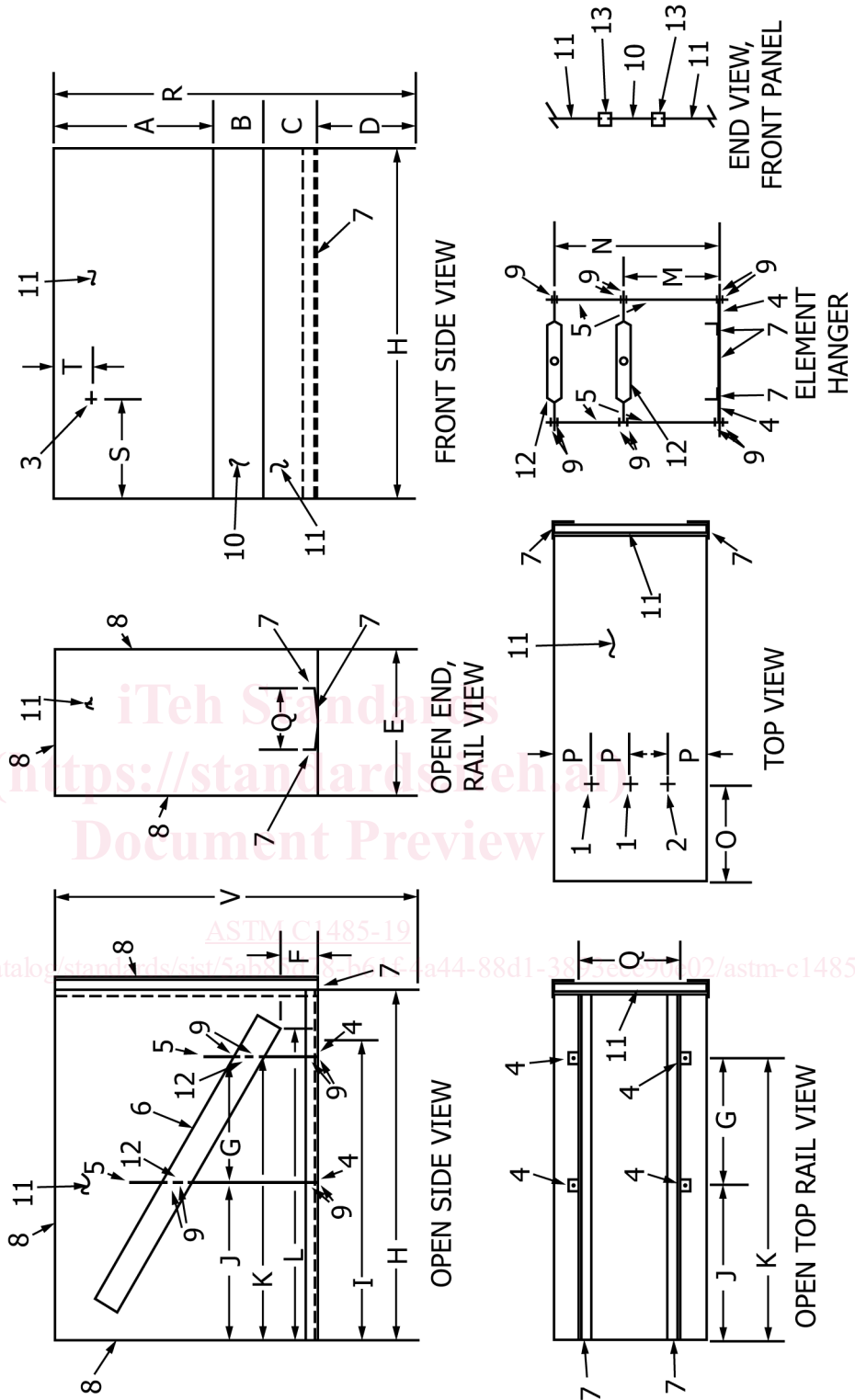

See 6.1.9 and 6.1.10 for hardware description and dimensions.

FIG. 1 Electric Radiant Panel Cabinet

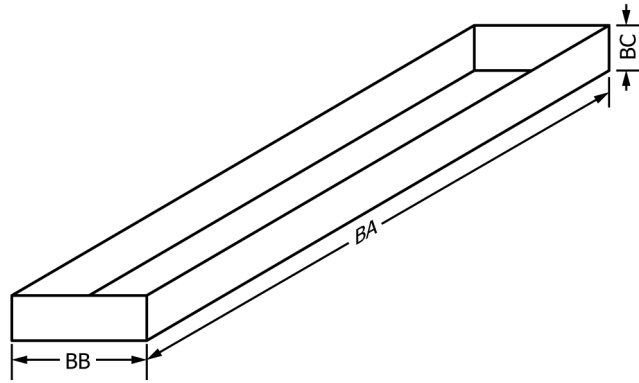

Hardware Description for Specimen Tray in Figs. 2-4. Open top box 0.16 mm (0.024 in.) thick (22–26 US standard gage) stainless steel sheet with the vertical edges of the box overlapped not to exceed 7 mm (0.273 in.) in seam width, and joined to be watertight.

Measurements for Specimen Tray in Fig. 2:

BA.	$60 \pm 0.2$ cm
BB.	15 cm
BC.	5 cm

FIG. 2 Specimen Tray

A. 32.5 cm (13 in.)	H. 71 cm (28 in.)	O. 20 cm (8 in.)
B. 10 cm (4 in.)	I. 60cm (24 in.) reference point	P. 7.5 cm (3 in.)
C. 13 cm (5 in.)	J. 33 cm (13 in.)	Q. 16 cm (6.25 in.)
D. 25.5 cm (10 in.)	K. 57 cm (23 in.)	R. 80 cm (32 in.)
E. 30.5 cm (12 in.)	L. 65 cm (26 in.)	S. 20 cm (8 in.)
F. 57 mm (2.25 in.)	M. 19 cm (7.5 in.)	T. 7.5 cm (3 in.)
G. 25.5mm (10 in.)	N. 33 cm (13.25 in.)	

## 7. Calibration and Standardization Apparatus

### 7.1 Apparatus:

#### 7.1.1 Total Flux Meter:

7.1.1.1 Overall Dimensions—15 cm (6 in.) × 15 cm (6 in.) × 10 cm (4 in.),

7.1.1.2 All metal case,

7.1.1.3 110v AC (high impedance),

7.1.1.4 Calibrated to a National or International standard,

7.1.1.5 Direct readout in  $W/cm^2$  shall read to three decimal places.

#### 7.1.2 Heat Flux Transducer:

7.1.2.1 Range—0 to 1.5  $W/cm^2$ —Measurements are in units of W per  $cm^2$ .

7.1.2.2 Water cooled, and

7.1.2.3 Calibrated to a National or International standard.

#### 7.1.3 Dummy Specimen Calibration Board:

7.1.3.1 Overall Dimensions—5 cm (2 in.) ×  $60 \pm 0.2$  cm long, by 15 cm wide, by 5 cm deep as depicted in Fig. 3

7.1.3.2 Centered Calibration Hole—2.5 cm (1 in.) in diameter centered on and along the centerline at 10 cm (4 in.), 20 cm (8 in.), 30 cm (12 in.), 40 cm (16 in.), 10, 20, 30, 40, and 50 cm (20 in.) locations (within  $\pm 0.1$  cm) measured from the zero reference at the maximum flux end of the specimen. (See Fig. 3.)

### 7.2 Radiant Heat Energy Flux Profile Standardization:

7.2.1 Place heat flux meter within 1 m (3 ft.) of the radiant panel.

7.2.2 Connect either of the cooling lines of the heat flux transducer to a tap water outlet. Connect the other side to discharge and drain (plastic tubing obtainable at a hardware store will work).

7.2.3 Establish a flow of 300 to 700 mL/min.

7.2.4 Plug the heat flux meter into the voltage regulator.

7.2.5 Connect the heat flux transducer to the heat flux meter.

7.2.6 Before calibration or testing check the reflector on the radiant heat source to ensure it is clean. If it needs cleaning, do so before turning it on for calibration or testing.

7.2.7 The heat flux transducer and the heat flux meter shall always be calibrated together against a standard source. They shall not be interchanged between calibration periods against a standard reference.