

TECHNICAL REPORT

Printed electronics –
Part 550-1: Quality assessment – Framework document on durability testing –
Mechanical and thermal testing

IEC TR 62899-550-1:2022

<https://standards.iteh.ai/catalog/standards/sist/905e0888-20cb-4dcf-aca9-fbed71efbf9a/iec-tr-62899-550-1-2022>



THIS PUBLICATION IS COPYRIGHT PROTECTED

Copyright © 2022 IEC, Geneva, Switzerland

All rights reserved. Unless otherwise specified, no part of this publication may be reproduced or utilized in any form or by any means, electronic or mechanical, including photocopying and microfilm, without permission in writing from either IEC or IEC's member National Committee in the country of the requester. If you have any questions about IEC copyright or have an enquiry about obtaining additional rights to this publication, please contact the address below or your local IEC member National Committee for further information.

IEC Secretariat
3, rue de Varembe
CH-1211 Geneva 20
Switzerland

Tel.: +41 22 919 02 11
info@iec.ch
www.iec.ch

About the IEC

The International Electrotechnical Commission (IEC) is the leading global organization that prepares and publishes International Standards for all electrical, electronic and related technologies.

About IEC publications

The technical content of IEC publications is kept under constant review by the IEC. Please make sure that you have the latest edition, a corrigendum or an amendment might have been published.

IEC publications search - webstore.iec.ch/advsearchform

The advanced search enables to find IEC publications by a variety of criteria (reference number, text, technical committee, ...). It also gives information on projects, replaced and withdrawn publications.

IEC Products & Services Portal - products.iec.ch

Discover our powerful search engine and read freely all the publications previews. With a subscription you will always have access to up to date content tailored to your needs.

IEC Just Published - webstore.iec.ch/justpublished

Stay up to date on all new IEC publications. Just Published details all new publications released. Available online and once a month by email.

Electropedia - www.electropedia.org

The world's leading online dictionary on electrotechnology, containing more than 22 300 terminological entries in English and French, with equivalent terms in 19 additional languages. Also known as the International Electrotechnical Vocabulary (IEV) online.

IEC Customer Service Centre - webstore.iec.ch/csc

If you wish to give us your feedback on this publication or need further assistance, please contact the Customer Service Centre: sales@iec.ch.

IEC TR 62899-550-1:2022

<https://standards.iteh.ai/catalog/standards/sist/905e0888-20cb-4dcf-aca9-fbed71efbf9a/iec-tr-62899-550-1-2022>



TECHNICAL REPORT

Printed electronics –
Part 550-1: Quality assessment – Framework document on durability testing –
Mechanical and thermal testing

[IEC TR 62899-550-1:2022](https://standards.iteh.ai/catalog/standards/sist/905e0888-20cb-4dcf-aca9-fbed71efbf9a/iec-tr-62899-550-1-2022)

<https://standards.iteh.ai/catalog/standards/sist/905e0888-20cb-4dcf-aca9-fbed71efbf9a/iec-tr-62899-550-1-2022>

INTERNATIONAL
ELECTROTECHNICAL
COMMISSION

ICS 19.060; 31.020

ISBN 978-2-8322-5893-4

Warning! Make sure that you obtained this publication from an authorized distributor.

CONTENTS

FOREWORD.....	3
INTRODUCTION.....	5
1 Scope.....	6
2 Normative references	6
3 Terms and definitions	6
4 Default items applicable to the test methods.....	7
4.1 Selection of test methods.....	7
4.2 Performance measurement	7
5 Mechanical test methods	7
5.1 Bending test.....	7
5.1.1 General	7
5.1.2 Test apparatus	7
5.2 Torsion test.....	9
5.2.1 General	9
5.2.2 Test apparatus	9
5.3 Stretching test	10
5.3.1 General	10
5.3.2 Test apparatus	10
6 Thermal test methods	10
6.1 Thermal cycle test.....	10
6.1.1 General	10
6.1.2 Tolerances	11
6.1.3 Conditioning	11
6.1.4 Temperature cycle	11
6.2 Steady heat test.....	11
6.2.1 General	11
6.2.2 Tolerances	11
6.2.3 Conditioning	11
6.2.4 Heating.....	12
Bibliography.....	13
Figure 1 – Bending apparatuses of IEC 62899-201	8
Figure 2 – Bending apparatus of IEC 62899-501-1.....	8
Figure 3 – Bending apparatus of IEC 62899-502-1.....	9
Figure 4 – Torsion apparatus of IEC 62899-502-1.....	9
Figure 5 – Stretching apparatus of IEC 62899-502-1.....	10
Figure 6 – Temperature cycle of IEC 62899-505	11

INTERNATIONAL ELECTROTECHNICAL COMMISSION

PRINTED ELECTRONICS –

Part 550-1: Quality assessment – Framework document on durability testing – Mechanical and thermal testing

FOREWORD

- 1) The International Electrotechnical Commission (IEC) is a worldwide organization for standardization comprising all national electrotechnical committees (IEC National Committees). The object of IEC is to promote international co-operation on all questions concerning standardization in the electrical and electronic fields. To this end and in addition to other activities, IEC publishes International Standards, Technical Specifications, Technical Reports, Publicly Available Specifications (PAS) and Guides (hereafter referred to as "IEC Publication(s)"). Their preparation is entrusted to technical committees; any IEC National Committee interested in the subject dealt with may participate in this preparatory work. International, governmental and non-governmental organizations liaising with the IEC also participate in this preparation. IEC collaborates closely with the International Organization for Standardization (ISO) in accordance with conditions determined by agreement between the two organizations.
- 2) The formal decisions or agreements of IEC on technical matters express, as nearly as possible, an international consensus of opinion on the relevant subjects since each technical committee has representation from all interested IEC National Committees.
- 3) IEC Publications have the form of recommendations for international use and are accepted by IEC National Committees in that sense. While all reasonable efforts are made to ensure that the technical content of IEC Publications is accurate, IEC cannot be held responsible for the way in which they are used or for any misinterpretation by any end user.
- 4) In order to promote international uniformity, IEC National Committees undertake to apply IEC Publications transparently to the maximum extent possible in their national and regional publications. Any divergence between any IEC Publication and the corresponding national or regional publication shall be clearly indicated in the latter.
- 5) IEC itself does not provide any attestation of conformity. Independent certification bodies provide conformity assessment services and, in some areas, access to IEC marks of conformity. IEC is not responsible for any services carried out by independent certification bodies.
- 6) All users should ensure that they have the latest edition of this publication.
- 7) No liability shall attach to IEC or its directors, employees, servants or agents including individual experts and members of its technical committees and IEC National Committees for any personal injury, property damage or other damage of any nature whatsoever, whether direct or indirect, or for costs (including legal fees) and expenses arising out of the publication, use of, or reliance upon, this IEC Publication or any other IEC Publications.
- 8) Attention is drawn to the Normative references cited in this publication. Use of the referenced publications is indispensable for the correct application of this publication.
- 9) Attention is drawn to the possibility that some of the elements of this IEC Publication may be the subject of patent rights. IEC shall not be held responsible for identifying any or all such patent rights.

IEC TR 62899-550-1 has been prepared by IEC technical committee 119: Printed Electronics. It is a Technical Report.

The text of this Technical Report is based on the following documents:

Draft	Report on voting
119/384/DTR	119/388/RVDTR

Full information on the voting for its approval can be found in the report on voting indicated in the above table.

The language used for the development of this Technical Report is English.

This document was drafted in accordance with ISO/IEC Directives, Part 2, and developed in accordance with ISO/IEC Directives, Part 1 and ISO/IEC Directives, IEC Supplement, available at www.iec.ch/members_experts/refdocs. The main document types developed by IEC are described in greater detail at www.iec.ch/publications.

A list of all parts in the IEC 62899 series, published under the general title *Printed electronics*, can be found on the IEC website.

The committee has decided that the contents of this document will remain unchanged until the stability date indicated on the IEC website under webstore.iec.ch in the data related to the specific document. At this date, the document will be

- reconfirmed,
- withdrawn,
- replaced by a revised edition, or
- amended.

iTeh STANDARD PREVIEW
(standards.iteh.ai)

[IEC TR 62899-550-1:2022](https://standards.iteh.ai/catalog/standards/sist/905e0888-20cb-4dcf-aca9-fbed71efbf9a/iec-tr-62899-550-1-2022)

<https://standards.iteh.ai/catalog/standards/sist/905e0888-20cb-4dcf-aca9-fbed71efbf9a/iec-tr-62899-550-1-2022>

INTRODUCTION

The purpose of this document is to describe a framework for evaluating the mechanical and thermal durability of printed and/or flexible electronics components and products.

Durability testing helps to improve the product and create greater revenue through customer satisfaction and retention, since it provides the means to identify and ensure a robust product. Therefore, the standardization and sharing of a consistent method for durability test is an effective way to facilitate the commoditization and raise the confidence and performance bar of the relevant industry.

IEC TC 119 has previously published several documents relating to the durability of flexible electronics components and products. Examples include IEC 62899-201, IEC 62899-501-1, IEC 62899-502-1, and IEC 62899-505. Although they cover a variety of flexible components and products, there are many similarities in methods and procedures for durability testing. More documents will continue to be published in this way. Hence, a general framework is necessary to ensure solid consistency in the test methods and procedures of printed and/or flexible electronics. Specifying the consistent methods for durability testing will help users, including businesses, developers, vendors, and end users, to select a suitable method for durability test and make consistent test procedures for printed electronics.

Among various durability tests, mechanical and thermal tests are the most common for printed and/or flexible electronics components and products, since these devices are capable of undergoing deformation under various mechanical and environmental conditions. The functional properties will be unaffected by the serious mechanical and environmental changes. Thus, this document, which is the first framework document for durability testing, addresses mechanical and thermal durability tests. Further, the types of testing and test method will be continuously updated and extended to push the growth of the printed electronics industry.

For consistency of the framework, the IEC 62899 series is preferentially referred to for mechanical and thermal tests. For example, the bending test methods and procedures are made with reference to IEC 62899-201, IEC 62899-501-1, and IEC 62899-502-1. In the case of thermal testing, the methods and procedures are prepared based on IEC 62899-505, whereas the temperature and humidity conditions refer to IEC 60721-3-7, which includes the environmental parameters for portable use.

This framework is intended to assist in making documents relating to the mechanical and thermal durability of printed and/or flexible electronics components and products consistent.

For a general applicability of this framework, other durability tests such as humidity, altitude and radiation will be considered.

PRINTED ELECTRONICS –

Part 550-1: Quality assessment – Framework document on durability testing – Mechanical and thermal testing

1 Scope

This part of IEC 62899, which is a Technical Report, provides a framework for evaluating the mechanical and thermal durability of printed and/or flexible electronics components and products. This includes the bending test, torsion test, stretching test, steady heat test as well as the thermal cycle test. These are typical conditions that are easily encountered in daily life for printed and/or flexible electronics components and products.

This document gives guidance for use for technical committees in the preparation of consistent standards relating to the quality assessment of printed and/or flexible electronics components and products. Consistent standards for durability testing will help users, including businesses, developers, vendors, and end users to select suitable methods for durability testing and make consistent test procedures for printed electronics.

2 Normative references

There are no normative references in this document.

3 Terms and definitions

For the purposes of this document, the following terms and definitions apply.

ISO and IEC maintain terminological databases for use in standardization at the following addresses:

- IEC Electropedia: available at <http://www.electropedia.org/>
- ISO Online browsing platform: available at <http://www.iso.org/obp>

3.1

device

material element or assembly of such elements intended to perform a required function

3.2

bending

deformation caused by external stress applied in a direction perpendicular to the device plane

3.3

torsion

deformation caused by external stress which twists the device, pulling each edge in different directions

3.4

stretching

deformation caused by external stress to extend or lengthen the device beyond the original length

3.5 temperature cycle

process of changing from a starting temperature to relatively higher and relatively lower temperatures, and then reaching the starting temperature again

4 Default items applicable to the test methods

4.1 Selection of test methods

The selection of the appropriate tests depends on the flexibility and application of the printed electronics device. Documents of TC 119 are preferentially considered as potential references. The testing conditions and the modification of the methods can be defined between customer and supplier.

4.2 Performance measurement

Before the start and after the end of each test, the measurement of the device performance can be performed in accordance with the manufacturer's instruction, unless otherwise stated.

The performance can be one or more of functional properties, electrical properties, and optical properties.

The typical test is performed without an electric power supply attached to device. If desired, it is possible to have a test with an electric power supply attached to the device during the next test.

5 Mechanical test methods

5.1 Bending test

5.1.1 General

The purpose of this test is to evaluate the stability and endurance of the printed electronics device against the dynamic bending stress which happens for a flexible movement.

The IEC 62899 series already has three kinds of bending test methods in IEC 62899-501-1, IEC 62899-201 and IEC 62899-502-1.

5.1.2 Test apparatus

The apparatus for bending the device can be selected from the bending tests specified in IEC 62899-201, IEC 62899-501-1 and IEC 62899-502-1 with their specific requirements (see Figure 1, Figure 2, and Figure 3). The bending cycle is performed by bending and returning to the neutral position with a predetermined radius.

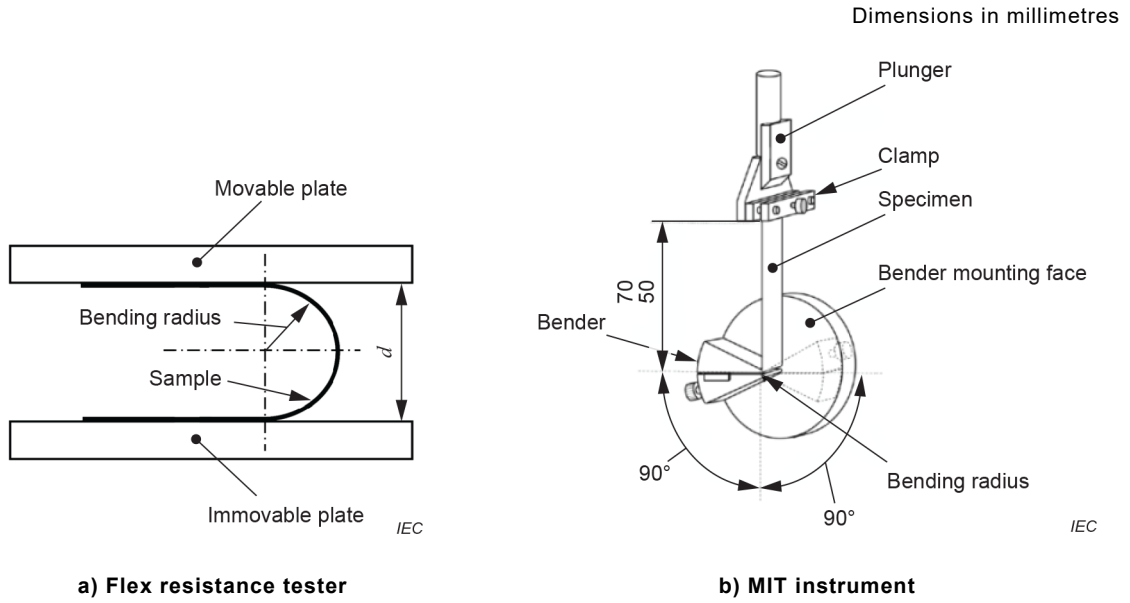
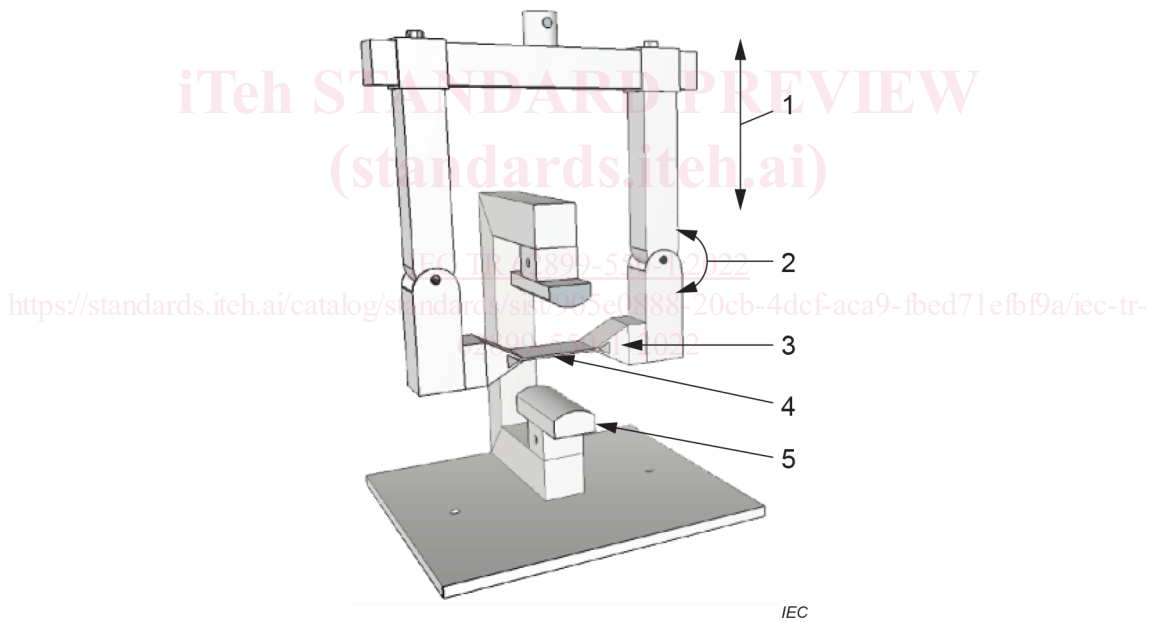

Figure 1 – Bending apparatuses of IEC 62899-201



Key:

- 1 direction of the upwards and downwards movements
- 2 right hinge
- 3 right parallel vice for device clamping
- 4 device
- 5 lower bending radius, which can be varied

Figure 2 – Bending apparatus of IEC 62899-501-1