



Designation: ~~C1860~~—~~18~~ **C1860** – 19

Standard Test Methods for Measurement of Tensile Strength or Bond Strength of Portland Cement-Based Plaster by Direct Tension¹

This standard is issued under the fixed designation C1860; the number immediately following the designation indicates the year of original adoption or, in the case of revision, the year of last revision. A number in parentheses indicates the year of last reapproval. A superscript epsilon (ϵ) indicates an editorial change since the last revision or reapproval.

1. Scope Scope*

1.1 These test methods cover procedures for determining the tensile strength of a section of portland cement-based plaster, the bond strength between portland cement-based plaster and a solid plaster base, or the fastener pull-out or lath pull-over strength for portland cement-based plaster bases over framing in either an exterior (stucco) or interior application. The test procedures are destructive in nature within the localized test areas and, after testing is concluded, require appropriate repair of the finish system as well as any underlying materials damaged during testing.

1.2 The test methods are suitable for use on portland cement-based plaster finish systems on both new and existing construction. Test method shall be conducted a minimum of 28 days after application of the portland cement-based plaster. Test Method A shall be used to determine the tensile strength or bond strength of direct-applied portland cement-based plaster and may be useful in evaluating the efficacy of different surface preparation characteristics, bonding agents, or both. Test Method B shall be used to determine the tensile strength of portland cement-based plaster installed over mechanically attached lath.

1.3 The test methods are suitable for use in both laboratory and field samples. No correlation shall be made between laboratory and field testing.

1.4 The test methods are not intended to evaluate the performance of the underlying construction or framing members. Test results on a particular building may be variable depending on the specimen location, condition, and installation, and are subject to interpretation by the test specifier.

1.5 The test methods are not intended to evaluate the performance of coatings applied to the surface of the portland cement-based plaster.

1.6 The test methods are not intended to be a pre-construction qualifier to determine if the surfaces are appropriate for application of portland cement plaster. The test methods are intended to be used as a tool to quantitatively evaluate existing portland cement plaster cladding that is suspected of questionable bond or uncertain fastening to the substrate.

1.7 The values stated in inch-pound units are to be regarded as the standard. SI values in parentheses are provided for information only.

1.8 *This standard may involve hazardous materials, operations, or equipment. This standard does not purport to address all of the safety concerns, if any, associated with its use. It is the responsibility of the user of this standard to establish appropriate safety, health, and environmental practices and determine the applicability of regulatory limitations prior to use.*

1.9 *This international standard was developed in accordance with internationally recognized principles on standardization established in the Decision on Principles for the Development of International Standards, Guides and Recommendations issued by the World Trade Organization Technical Barriers to Trade (TBT) Committee.*

2. Referenced Documents

2.1 *ASTM Standards:*

[C11 Terminology Relating to Gypsum and Related Building Materials and Systems](#)

[C219 Terminology Relating to Hydraulic Cement](#)

[C926 Specification for Application of Portland Cement-Based Plaster](#)

[C1063 Specification for Installation of Lathing and Furring to Receive Interior and Exterior Portland Cement-Based Plaster](#)

¹ This test method is under the jurisdiction of ASTM Committee C11 on Gypsum and Related Building Materials and Systems and is the direct responsibility of Subcommittee C11.02 on Specifications and Test Methods for Accessories and Related Products.

Current edition approved ~~March 1, 2018~~ March 1, 2019. Published ~~March 2018~~ April 2019. Last previous edition approved in 2018 as C1860–18. DOI: [10.1520/C1860-18](https://doi.org/10.1520/C1860-18); [10.1520/C1860-19](https://doi.org/10.1520/C1860-19).

*A Summary of Changes section appears at the end of this standard

C1583/C1583M Test Method for Tensile Strength of Concrete Surfaces and the Bond Strength or Tensile Strength of Concrete Repair and Overlay Materials by Direct Tension (Pull-off Method)

D3665 Practice for Random Sampling of Construction Materials

E2359/E2359M Test Method for Field Pull Testing of an In-Place Exterior Insulation and Finish System Clad Wall Assembly

2.2 American Society of Civil Engineers:

SEI/ASC 7 Minimum Design Loads for Buildings and Other Structures

2.3 U.S. Department of Commerce:

Voluntary Product Standard PS 1-09 Structural Plywood

3. Terminology

3.1 Terms shall be as defined in Terminologies C11 and C219, except as modified herein.

3.2 Definitions:

3.2.1 *adhesive, n*—high strength adhesive of appropriate type to adhere test module to plaster. Expanding foam adhesives shall be prohibited.

3.2.2 *bond strength, n*—the maximum stress as measured in force per unit area that a plaster specimen can withstand in direct tension before failure either (a) between any two stucco coats, or (b) between the base coat(s) and the substrate.

3.2.3 *fastener pull-out, n*—failure mode by which the fastener released from the substrate in withdrawal.

3.2.4 *lath pull-over, n*—failure mode by which the lath (metal or non-metallic) pulls over the head of the fastener, leaving the fastener intact.

3.2.5 *proof, n*—the maximum safe test load as set in this standard.

3.2.6 *substrate, n*—the surface to which the plaster is attached, either directly or with lath (metal or non-metallic).

3.2.7 *tensile strength, n*—the stress as measured in force per unit area that a plaster specimen can withstand in direct tension before failure within any individual stucco coat.

3.2.8 *tensile load, n*—the load as measured in force that a plaster specimen can withstand in direct tension at failure.

4. Significance and Use

4.1 The purpose of the test methods in this standard is to measure the tensile strength or bond strength of portland cement-based plaster to its substrate. The values obtained using the test methods are not purported to be representative of the actual wind load capacity or other structural properties of a specific portland cement-based plaster installation but may be helpful in assessing such load capacities.

4.2 Because the test methods described in this standard are used for evaluation of portland cement-based plaster cured at least 28 days, load results obtained by either test method must be interpreted based on sound engineering practice, applicable building regulations, and codes having jurisdiction. The decision of whether to use the load results directly or to use the load results as modified by an appropriate safety factor to obtain acceptable working loads is left to the discretion of the test specifier. Determination of an appropriate safety factor shall be left to the discretion of the test specifier. Methods to calculate a safety factor and a maximum permitted working load are provided in the Appendix.

4.3 When the test methods contained in this standard are used on test specimens installed on existing structures, the test results shall not be generalized to a larger wall area without sufficient test sampling. Such efforts should be based on engineering experience and judgment of the test specifier.

5. Apparatus

5.1 Pull test frame fabricated from metal or wood, as required, with capability of applying a concentric pull force to the test module and distributing reaction forces on adjacent wall components. It is intended that the pull test frame be easily transportable and relocated so that it can readily be used on saw-horses, scaffolding, lifts, and swing-stages. The pull test frame as specified in Test Method E2359/E2359M shall be permitted in this test method.

5.2 A coupling device to connect the pull test module to the load cell and test frame. The coupling device shall be designed to withstand the tensile capacity of the device without yielding, and to transmit the tensile force parallel to and in line with centerline of the test specimen without imparting torsion or bending stress to the specimen. The coupling device shall be fitted with a metal rod fixed at the load cell and threaded at the opposite end to permit the application of tensile loads to the test module in a controlled manner with incrementally increasing load intensities.

5.3 A load cell with force gauge having a capacity of at least the proof values specified in 7.3, and an accuracy of $\pm 2\%$. Load cells shall be calibrated annually.

5.4 Electric angle grinder with masonry cutting blade of sufficient diameter to fully penetrate plaster thickness and grinding blade to level surface of plaster.

5.5 Miscellaneous hand tools, bolts, and connection hardware.

5.6 Test Method A:

5.6.1 Pull test module consisting of a minimum 6 by 6 in. (153 by 153 mm) and maximum 48 by 48 in. (1220 by 1220 mm) U.S. DOC Voluntary Product Standard PS 1-09 plywood minimum of 3/4 in. (19 mm) nominal thickness bonding panel (one for each specimen intended for testing) and one minimum 1/4 in. (6 mm) thick steel plate sized to match length and width of the wooden bonding panel which is moved from specimen to specimen.² The steel plate module shall include an integral steel nut located at the plan center of the plate of size to receive the threaded rod that connects the load cell to the module and provisions for 7/8 in. (22 mm) length, #14 wood screws to fasten the steel plate to the plywood bonding panel. Adhere one nominal 3/4 in. (19 mm) thick wooden bonding panel to the surface of the stucco at each specimen location. For testing purposes, temporarily fasten the steel

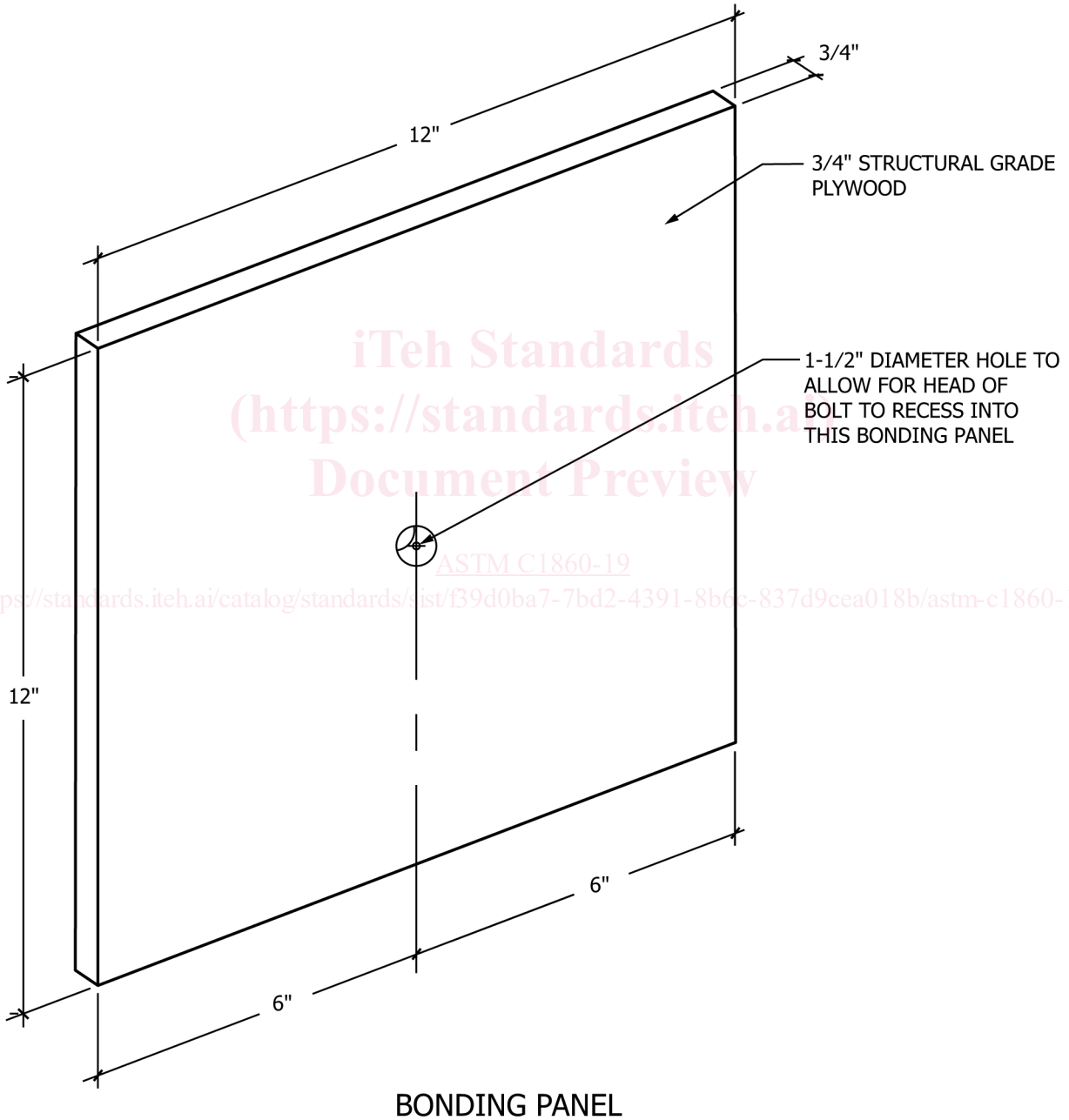

FIG. 1 Example of 12 by 12 in (305 by 305 mm) Bonding Panel

² Module shall be sized as large as possible to capture as large of a stucco area as possible. In consideration of geometrical constraints and safety hazards associated with the weight and size of steel plates sized to match the wood templates, a minimum 6 by 6 in. (153 by 153 mm) shall be permitted.

bolting template at each adhered bonding panel in succession. Fasteners between the steel plate module and plywood bonding panel shall be spaced at a minimum 2 in. on center and maximum 2 in. edge distance. (See Figs. 1 and 2 for an example of a 12 by 12 in. (305 by 305 mm) test ~~module~~:module.)

5.7 Test Method B:

5.7.1 Pull test module consisting of a 26 by 26 in. (660 by 660 mm) U.S. DOC Voluntary Product Standard PS-1 rated plywood minimum of 3/4 in. (19 mm) nominal thickness bonding panel (one for each specimen intended for testing) and one 26 by 26 by 1/4 in. (19 by 19 by 6 mm) thick steel plate which is moved from specimen to specimen. The steel plate module shall include an integral steel nut located at the plan center of the plate of size to receive the threaded rod that connects the load cell to the module and provisions for 7/8 in. (22 mm) length, #14 wood screws to fasten the steel plate to the plywood bonding panel. (See Figs. 3 and 4.) Adhere one 3/4 in. (19 mm) thick wooden bonding panel to the surface of the stucco at each specimen location. For testing purposes, temporarily fasten the steel bolting template at each adhered bonding panel in succession. Fasteners between the steel plate module and plywood bonding panel shall be spaced at a minimum 2 in. on center and maximum 2 in. edge distance. (See Figs. 3 and 4 for an example of a 26 by 26 in. (660 by 660 mm) test ~~module~~:module.)

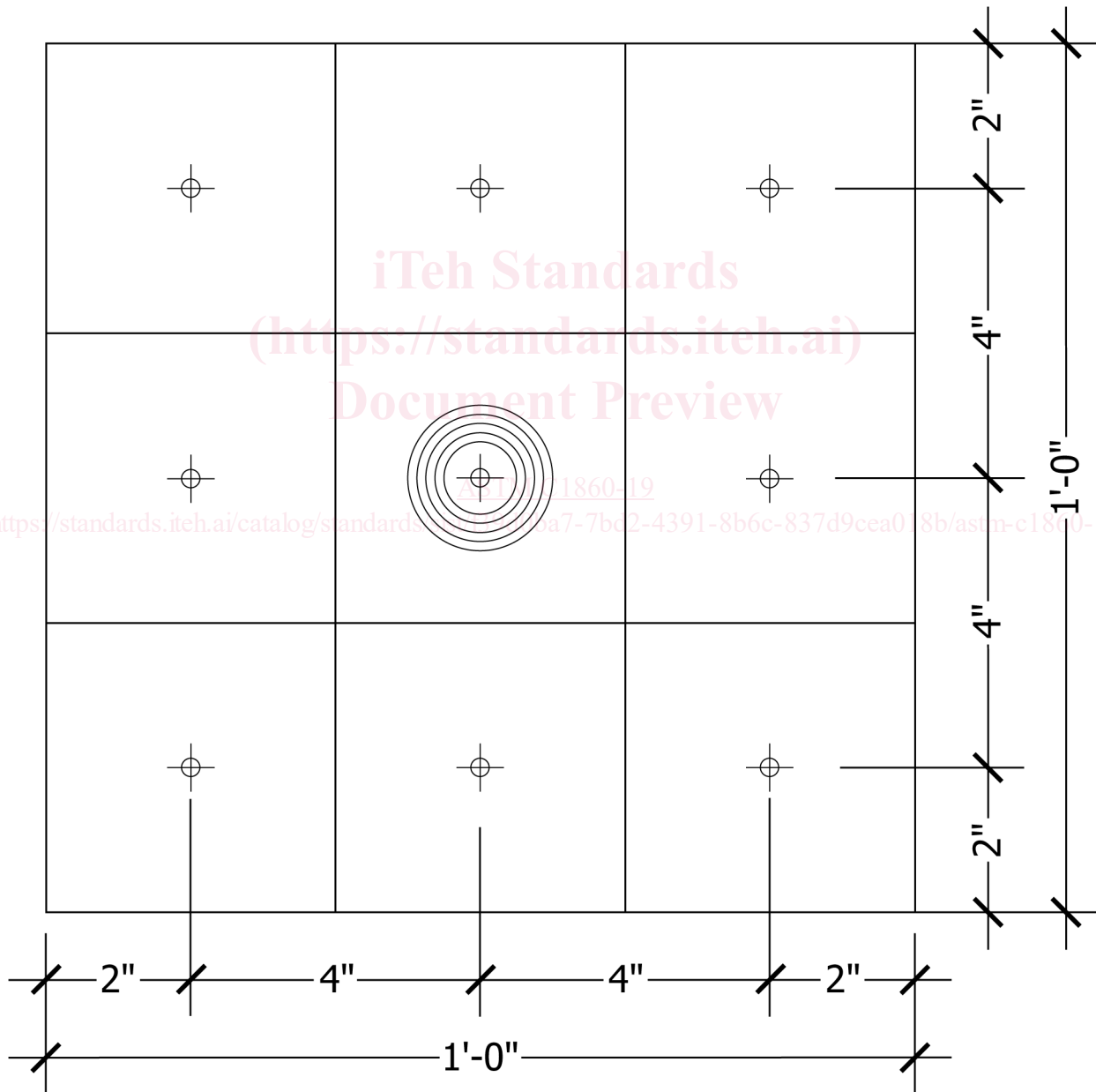

(8) #14 1/4" DIAM. × 7/8" WOOD LAG SCREWS

FIG. 2 Sample Layout of 12 in. (305 mm) Square Steel Bolting Template

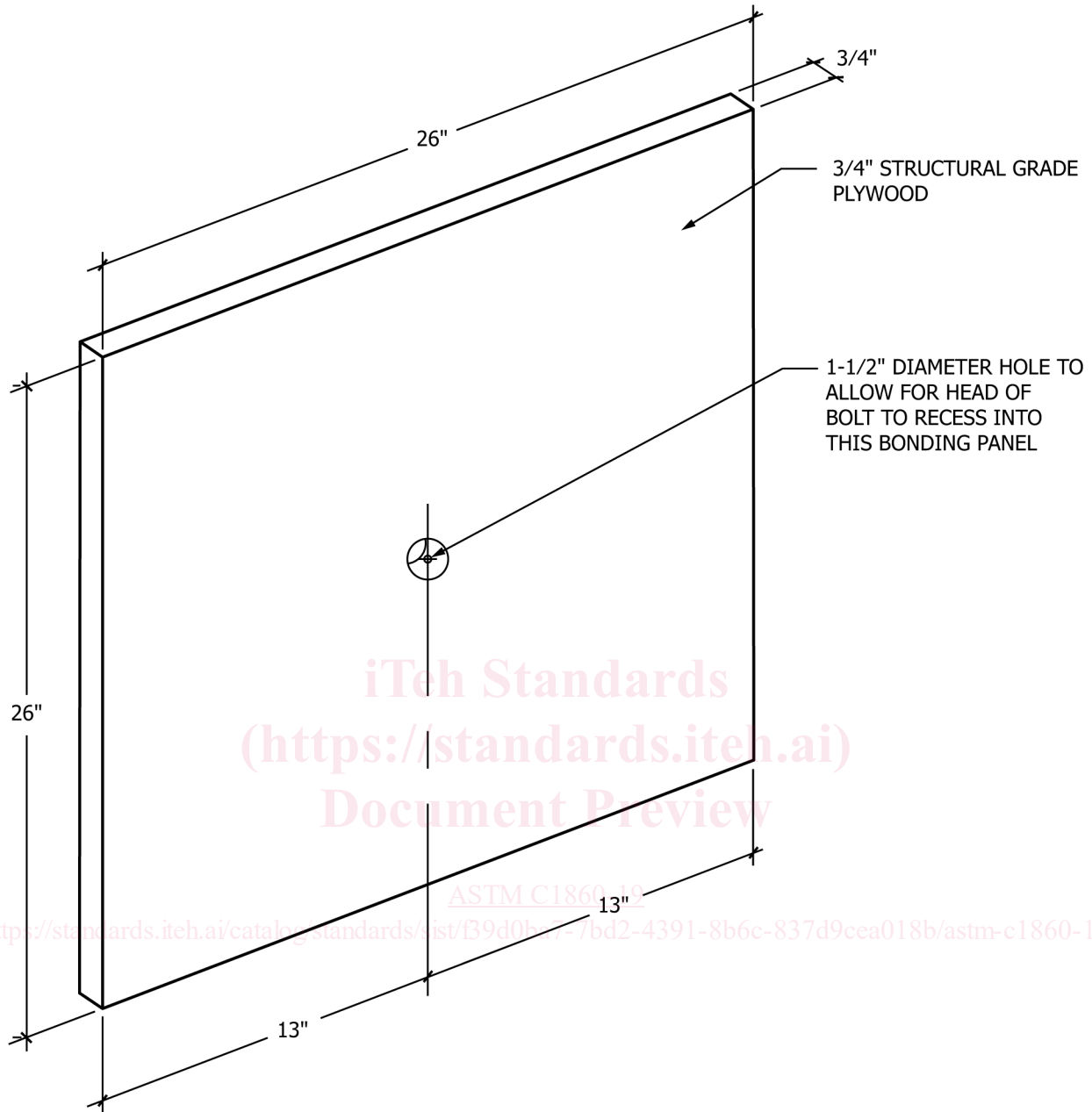

BONDING PANEL

FIG. 3 Example of 26 in. (660 mm) Square Plywood Bonding Panel for Framing Members Spaced at 24 in. (610 mm) or less

5.8 As an alternate to the 1/4 in. (6 mm) steel panel specified in 5.6.1 and 5.7.1, the test specifier shall be permitted to substitute a minimum 3/4 in. (19 mm) U.S. DOC Voluntary Product Standard PS-1 rated plywood panel of equivalent dimensions.

5.9 An exploded view of the test assembly components (pull test frame, coupling device, load cell, and pull test module as described in 5.1, 5.2, 5.3, 5.6, and 5.7, respectively) is shown in Fig. 5.

6. Test Specimen

6.1 *Sampling:*

6.1.1 Sampling locations and number of specimens shall be determined by test specifier.

6.1.2 Where random sampling is specified, sampling locations and number of specimens shall be determined in accordance with Practice D3665. Where sampling is targeted in areas with suspect deficiencies, such sampling shall be identified and the means by which the targeted areas were identified (for example, acoustical sounding) shall be described in the report.

6.2 *Surface Preparation:*

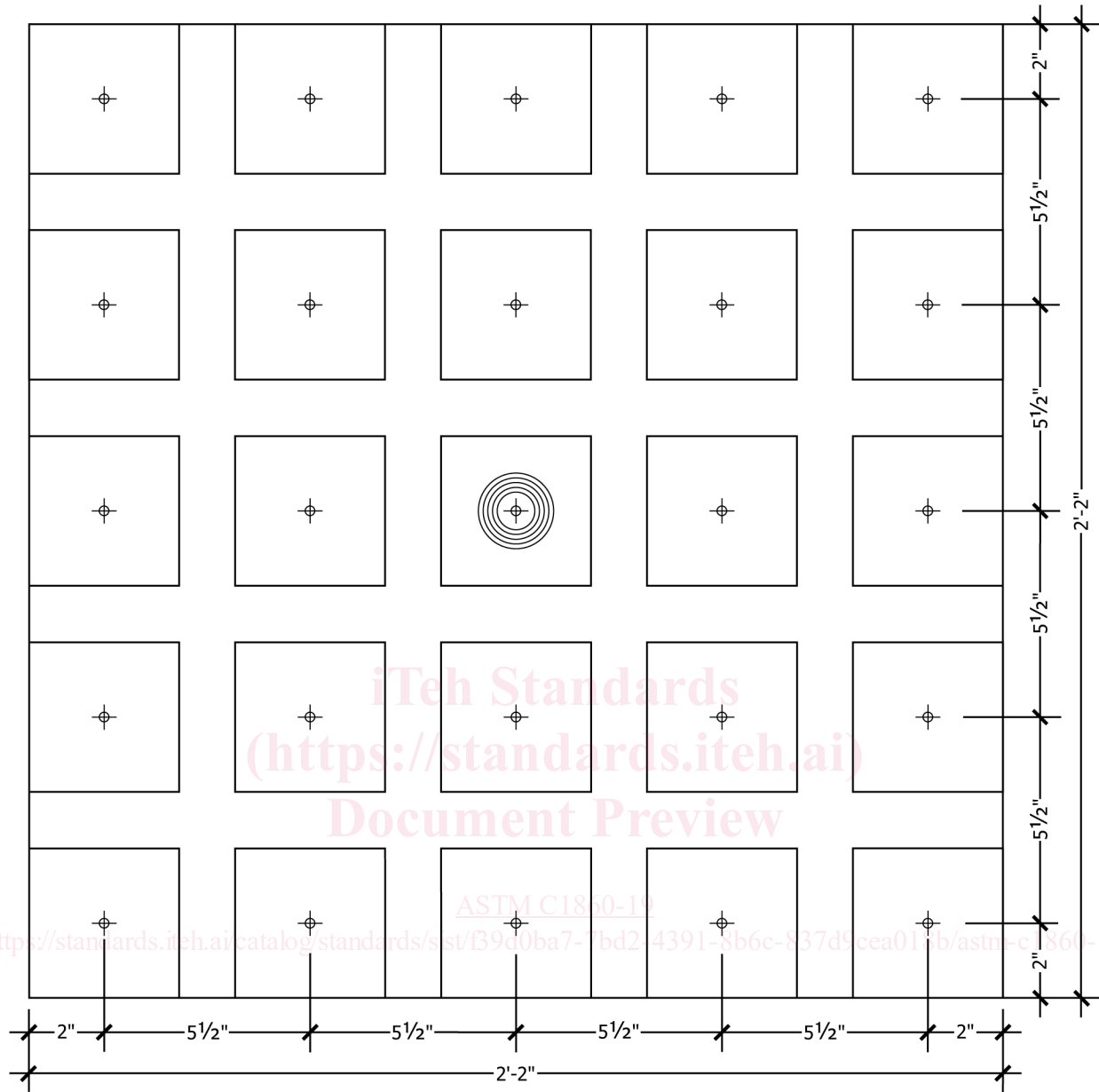

(24) #14 1/4" DIAM. × 7/8" WOOD LAG SCREWS

FIG. 4 Sample Layout of 26 in. (660 mm) Square Steel Bolting Template for Framing Members Spaced at 24 in. (610 mm) or less

6.2.1 Remove all surface contaminants, loose debris, and dust that may interfere with bond.

6.2.2 If surface texture profile of plaster is such that good bond cannot be achieved, grind the surface texture to a level surface that permits good bond.

6.3 Test Method A:

6.3.1 Where testing is to be performed at a targeted area of suspected unbonded or debonded stucco (determined through sounding or another applicable method), the area to be tested shall be a square equal to the suspected area of unbonded or debonded stucco multiplied by a factor of 2, up to a maximum area of 48 by 48 in. (1220 by 1220 mm). Where testing is randomized, the area to be tested shall be sized to match the wood bonding panel as described in 5.6.1.

6.3.2 Mark an outline over the area to be tested as described in 6.3.1. Cut along the outline through the full depth of the stucco and plaster base, taking care to avoid damaging the substrate.

6.3.3 Attach the plywood bonding panel to the surface of the test specimen using the adhesive. Ensure that the plywood is centered on the test specimen and the edges of the plywood align with the edges of the score cut. Apply and cure the adhesive in accordance with the manufacturer's instructions. Prevent adhesive that drips down the side of the specimen and into the annular