



Designation: F1169 – 19

Standard Consumer Safety Specification for Full-Size Baby Cribs¹

This standard is issued under the fixed designation F1169; the number immediately following the designation indicates the year of original adoption or, in the case of revision, the year of last revision. A number in parentheses indicates the year of last reappraisal. A superscript epsilon (ϵ) indicates an editorial change since the last revision or reappraisal.

INTRODUCTION

This consumer safety specification addresses crib incidents that were identified by the U.S. Consumer Product Safety Commission (CPSC).

CPSC received reports of strangulations incidents associated with crib corner post extensions and incidents concerning failure of crib hardware and other structural components of cribs that also resulted in fatalities.

In response to the incident data collected by the CPSC, this consumer safety specification attempts to minimize the risk of injury or death due to: failure of mattress support hardware, failure of glued or bolted connections, side latch failure, and dislodgment of teething rails. This safety specification also addresses incidents associated with poor maintenance or assembly by means of requirements for the contents of instructional literature that must accompany a crib.

1. Scope

1.1 This consumer safety specification establishes performance requirements and test procedures to determine the structural integrity of full-size cribs. It also contains design requirements addressing entanglement on crib corner post extensions, and requirements for warning labels and instructional material. It also covers bassinet, changing table, or similar accessories to a crib that when in the manufacturer's recommended use position are in the occupant retention area. These accessories shall also comply with the applicable requirements of the ASTM International standards addressing those accessories. For example, a changing table that attaches to a crib shall also comply with the applicable requirements in Consumer Safety Specification F2388. This specification does not cover inflatable products.

1.2 No crib produced after the approval date of this consumer safety specification shall, either by label or other means, indicate compliance with this specification unless it conforms to all requirements contained herein.

1.3 The values stated in inch-pound units are to be regarded as standard. The values given in parentheses are mathematical conversions to SI units that are provided for information only and are not considered standard.

1.4 The following safety hazards caveat pertains only to the test methods portion, Section 7, of this specification: *This standard does not purport to address all of the safety concerns, if any, associated with its use. It is the responsibility of the user of this standard to establish appropriate safety, health, and environmental practices and determine the applicability of regulatory limitations prior to use.*

1.5 *This international standard was developed in accordance with internationally recognized principles on standardization established in the Decision on Principles for the Development of International Standards, Guides and Recommendations issued by the World Trade Organization Technical Barriers to Trade (TBT) Committee.*

2. Referenced Documents

2.1 ASTM Standards:²

D3359 Test Methods for Rating Adhesion by Tape Test
F963 Consumer Safety Specification for Toy Safety
F2388 Consumer Safety Specification for Baby Changing Products for Domestic Use

2.2 Federal Standards:³

16 CFR 1303 Ban of Lead-Containing Paint and Certain Consumer Products Bearing Lead-Containing Paint
16 CFR 1500.3 Definitions

¹ This specification is under the jurisdiction of ASTM Committee F15 on Consumer Products and is the direct responsibility of Subcommittee F15.18 on Cribs, Toddler Beds, Play Yards, Bassinets, Cradles and Changing Tables.

Current edition approved March 15, 2019. Published April 2019. Originally approved in 1988. Last previous edition approved in 2013 as F1169 – 13. DOI: 10.1520/F1169-19.

² For referenced ASTM standards, visit the ASTM website, www.astm.org, or contact ASTM Customer Service at service@astm.org. For *Annual Book of ASTM Standards* volume information, refer to the standard's Document Summary page on the ASTM website.

³ Available from the Consumer Product Safety Commission, Washington, DC 20207.

16 CFR 1500.44 Method for Determining Extremely Flammable & Flammable Solids

16 CFR 1500.48 Technical requirements for Determining a Sharp Point in Toys or Other Articles Intended for Use by Children Under Eight Years of Age

16 CFR 1500.49 Technical Requirements for Determining a Sharp Metal or Glass Edge in Toys or Other Articles Intended for Use by Children Under Eight Years of Age

16 CFR 1500.50–.52 Test Methods for Simulating Use and Abuse of Toys and Other Articles Intended for Use by Children

16 CFR 1501 Method for Identifying Toys and Other Articles Intended for Use by Children Under Three Years of Age Which Present Choking, Aspiration or Ingestion Hazards Because of Small Parts

2.3 *European Standard*.⁴

EN 716 Furniture - Children's cots and folding cots for domestic use

3. Terminology

3.1 *accessory*, *n*—component with a rigid frame such as a bassinet or changing table that attaches to or rests on a crib in the occupant retention area only and that because of its structure, location, or movement, may expose crib occupant to an opening presenting an entrapment hazard.

3.1.1 *Discussion*—It does not include (1) items that hang outside the occupant retention areas, such as organizers and storage bags; (2) canopies that have no rigid frame members running alongside any top rail; (3) components that attach only to another accessory and not directly to the crib; (4) dressing tables and bassinets that are attached to the crib and outside the occupant retention area; or (5) toy accessories covered under 5.11.

3.2 *cord*, *n*—length of slender flexible material including monofilaments, rope, woven and twisted cord, plastic and textile tapes, ribbon, and those materials commonly called string.

3.3 *dynamic load*, *n*—application of an impulsive force by a free falling mass.

3.4 *folding side*, *n*—a side, or a part thereof, that is intended to fold or pivot with respect to the frame when the product is in the manufacturer's recommended use position to provide easier access to the occupant.

3.5 *full-size crib*, *n*—a bed that is designed to provide sleeping accommodations for an infant that is intended for use in the home and is within a range of ± 2 in. (± 5.1 cm) of the interior length or width dimensions specified for full-size baby cribs in 5.7.

3.5.1 *Discussion*—Cribs having an interior length dimension either greater than 55 in. (139.7 cm) or smaller than 49 $\frac{3}{4}$ in. (126.3 cm), or an interior width dimension greater than 30 $\frac{5}{8}$ in. (77.7 cm) or smaller than 25 $\frac{3}{8}$ in. (64.3 cm), or both, are considered non-full-size cribs and do not fall within the scope of this specification.

⁴ Available from European Committee for Standardization (CEN), 36 rue de Stassart, B-1050, Brussels, Belgium, <http://www.cenorm.be>.

3.6 *key structural elements*, *n*—side assemblies, end assemblies, mattress supports, or stabilizing bars which create the occupant retention area.

3.7 *manufacturer's recommended use position*, *n*—any position that is presented by the manufacturer in any descriptive or instructional literature as a normal, allowable, or acceptable configuration for use of the product; this specifically excludes positions that the manufacturer shows in a like manner in its literature to be unacceptable, unsafe, or not recommended.

3.8 *mattress support system*, *n*—those components of a bed structure that are intended for a mattress to rest upon.

3.9 *moveable side*, *n*—top portion of an otherwise stationary side that is intended to move with respect to the frame (other than a folding side) when the product is in the manufacturer's recommended use position to provide easier access to the occupant.

3.10 *nonpaper label*, *n*—any label material (such as plastic or metal) that either will not tear without the aid of tools or tears leaving a sharply defined edge or labels made from fabric.

3.11 *occupant*, *n*—that individual who is in the product when it is setup in one of the manufacturer's use positions.

3.12 *occupant retention area*, *n*—any area designated by the manufacturer as being the recommended sleeping area for the occupant of the product.

3.13 *static load*, *n*—force applied by a calibrated force gauge or by dead weights.

3.14 *stationary side*, *n*—a side or end panel that is not intended to fold, slide or move with respect to the frame when the product is in the manufacturer's recommended use position.

3.15 *strap*, *n*—piece of flexible material of which the width is significantly greater than the thickness.

3.16 *structural failure*, *n*—damage to a component(s) or assembly resulting in partial separation (greater than 0.040 in. (1.00 mm) over original configuration), or complete separation of the component(s) or assembly.

4. Calibration and Standardization

4.1 All testing shall be conducted on a concrete floor which may be covered with $\frac{1}{8}$ -in. (3-mm) thick vinyl floor covering.

4.2 The crib shall be completely assembled, unless otherwise noted, in accordance with the manufacturer's instructions.

4.3 No testing shall be conducted within 48 h of manufacturing.

4.4 The item to be tested shall be in a room with ambient temperature of $73.4 \pm 9^\circ\text{F}$ ($23 \pm 5^\circ\text{C}$) for at least 24 h prior to testing. Testing shall then be conducted within this temperature range.

5. General Requirements

5.1 Before performing any of the tests in this specification all wood parts shall be smooth and free of splinters.

5.1.1 All wood parts shall be free from splits, cracks, or other defects that might lead to structural failure.

5.2 *Surface Coatings*—The paint or surface coating on the product shall comply with 16 CFR 1303.

5.3 *Small Parts*—There shall be no small parts as defined by 16 CFR 1501 before testing or liberated as a result of testing to this specification.

5.4 *Corner Posts:*

5.4.1 No corner post assembly shall extend more than 0.06 in. (1.50 mm) above the upper edge of an end or side panel, whichever is higher, when measured from the lowest point on the upper edge of the end or side panel within 3 in. (76 mm) from the outermost contour of the post or elbow (see Fig. 1).

5.4.1.1 This requirement applies when any moveable side/folding side is in either the raised or lowered position.

5.4.2 The limitations in 5.4.1 do not apply to a corner post assembly that extends at least 16 in. (400 mm) above the uppermost surface of the side rail in its highest position.

5.4.3 Corner posts intended to accept removable vertical extensions made up of two or more segments (such as canopy post extensions) shall not permit the attachment of individual segments such that the resultant vertical extension would be in violation of the dimensional requirements of 5.4.

5.5 *Slat Construction*—Slats shall not contain any lateral/transverse joints such as finger-joints, and other means of joining pieces of lumber end-to-end are not permitted.

5.6 *Crib Side Configurations:*

5.6.1 Cribs with side(s) having movable components intended to aid in access to the occupant shall have those sides rigidly attached to the crib ends and contain no movable section less than 20 in. (51 cm) above the top of the mattress support in its lowest adjustable position.

5.6.2 Cribs with only stationary sides shall meet the following criteria: The height of the uppermost surface of any top horizontal rail shall be at least 15 in. (38 cm) above the top surface of the mattress support in its highest adjustable position.

5.6.3 Should any adjacent sides of a crib that have slats or spindles have a height difference between their top rails of more than 6 in. and either of their top rails are less than 40 in. (102 cm) high as measured from the top of the mattress support in its lowest position to the top of the sides, then the higher of the two sides may not have a toe hold (as defined in 5.9) that is located more than 6 in. (15 cm) below the top of the side. The height difference shall be measured within 6 in. (15 cm) of the intersection of the two sides. This provision does not apply to folding or moveable sides. The top horizontal rail of an adjacent side shall not be considered a toe hold. This provision does not apply to toe holds located less than 3 in. (7.6 cm) from the top of the mattress support in its lowest position as allowed in 5.9.

5.7 *Full-Size Baby Cribs—Dimensions:*

5.7.1 The interior dimensions shall be $28 \pm \frac{5}{8}$ in. (71 ± 1.6 cm) wide as measured between the innermost surfaces of the crib sides and $52 \frac{3}{8} \pm \frac{5}{8}$ in. (133 ± 1.6 cm) long as measured between the innermost surfaces of the crib end panels, slats, rods, or spindles. Both measurements are to be made at the level of the mattress support in each of its adjustable positions and no more than 2 in. (5 cm) from the crib corner posts or from the first spindle to the corresponding point of the first spindle at the other end of the crib. If a crib has contoured or decorative spindles, in either or both of the sides or ends, the measurement shall be determined from the largest diameter of the first turned spindle within a range of 4 in. (10 cm) above the mattress support in each of its adjustable positions, to a corresponding point on the first spindle or innermost surface of the opposite side of the crib.

5.7.2 *Rail Height*—The rail height dimensions shall be as follows:

5.7.2.1 The height of the rail and end panel as measured from the top of the rail or panel in its lowest position to the top of the mattress support in its highest position shall be at least 9 in. (22.8 cm).

5.7.2.2 The height of the rail and end panel as measured from the top of the rail or panel in its highest position to the top of the mattress support in its lowest position shall be at least 26 in. (66 cm).

5.8 *Spacing of Crib Components:*

5.8.1 The distance between components (such as slats, spindles, crib rods, and corner posts) shall not be greater than $2 \frac{3}{8}$ in. (6 cm) at any point. Measurement of distance between contoured or irregular slats or spindles shall be done by a $2 \frac{3}{8}$ -in. wide by 4-in. high by 4-in. long (6-cm wide by 10-cm high by 10-cm long) rectangular block that shall not pass through the space.

5.8.2 The distance between such components shall not exceed $2 \frac{1}{2}$ in. (6.3 cm) when a 20-lb (9-kg) direct force is applied in accordance with the test method in 7.8. For contoured or irregular slats or spindles, the spacing shall not permit passage of a $2 \frac{1}{2}$ -in. wide by $3 \frac{1}{4}$ -in. high by $3 \frac{1}{4}$ -in. long (6.3-cm wide by 8.2-cm high by 8.2-cm long) rectangular block above and below the loading wedge when a 20-lb (9-kg) direct force is applied in accordance with said test method.

5.9 *Toe Holds*—Crib end panels and sides or any attachment thereto shall have no horizontal bar, ledge, projection, or other

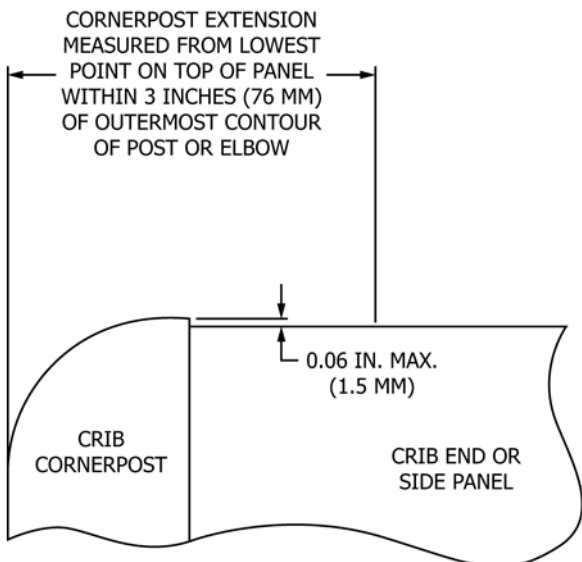

FIG. 1 Illustration of Requirements for Crib Corner Post Extensions

surface accessible to a child inside the crib capable of being used as a toehold located more than 3 in. (7.6 cm) and less than 20 in. (51 cm) above the mattress support in its lowest position when the side rail is in its highest position. In no case will any gap between the top surface of the mattress support and the bottom of the lower horizontal rail be permitted. For the purposes of this paragraph, any horizontal ledge or projection with a depth dimension greater than $\frac{3}{8}$ in. (1 cm) shall constitute a toehold. The top horizontal rail of an adjacent side shall not be considered a toe hold.

5.10 *Hardware and Fasteners*—A crib shall be designed and constructed in a manner that eliminates from any hardware accessible to a child within the crib the possibility of the hardware's presenting a mechanical hazard through pinching, bruising, lacerating, crushing, breaking, amputating, or otherwise injuring portions of the human body when the crib is in normal use or when subjected to reasonably foreseeable damage or abuse.

5.10.1 *Wood Screws*—Wood screws shall not be used in the assembly of stationary sides, folding sides, or stabilizing bars to crib ends or other components that must be removed by the consumer in the normal disassembly of a crib.

5.10.1.1 No crib shall require consumer assembly of key structural elements using wood screw fasteners. This shall not apply to drawers or other storage components or accessory items.

5.10.2 Factory assembly using wood screws on key structural elements is allowed if the wood screws are a second method of attachment or the wood screws include a lock washer, glue or other means to impede loosening or detachment.

5.10.3 Metal inserts with external wood screw threads for screwing into a wood component and providing internal machine threads to accommodate a machine screw shall be glued or include other means to impede loosening or detaching.

5.10.4 Wood screws are permitted to be used as the primary fasteners or only fasteners for non-key structural elements.

5.10.5 Metal threaded fasteners, such as sheet metal screws and machine screws, secured into metal components and used to attach key structural elements shall have lock washers, self-locking nuts, or other means to impede loosening as defined in 6.6.2 or detachment during the testing required by this specification.

5.11 Toy accessories attached to, removed from, or sold with a product, as well as their means of attachment, must meet applicable requirements of Consumer Safety Specification F963.

5.12 *Recordkeeping*—A manufacturer or importer of cribs shall keep and maintain for six years after production or importation of each lot, or other suitable identifying unit, records of sale, distribution, and results of all inspections and tests conducted in accordance with this specification. These records shall be made available upon request, at reasonable times to any officer, employee, or agent action on behalf of the Consumer Product Safety Commission. The manufacturer or importer shall permit such officer, employee, or agent to

inspect and copy such records, make such inventories of stock as he deems necessary, and otherwise verify the accuracy of such records.

5.13 Except as noted in 6.7, before and after testing, the product shall comply with all the requirements of Section 5.

5.14 There shall be no hazardous sharp points or edges as defined by 16 CFR 1500.48 and 16 CFR 1500.49 before or after testing to this specification.

5.15 There shall be no flammable solids as defined in 16 CFR 1500.3 (c) (6) (vi) before or after testing in accordance with this specification.

5.16 *Openings*—Holes or slots that extend entirely through a wall section of any rigid material less than 0.375-in. (9.53-mm) thick and admit a 0.210-in. (5.33-mm) diameter rod shall also admit a 0.375-in. (9.53-mm) diameter rod. Holes or slots that are between 0.210 in. (5.33 mm) and 0.375 in. (9.53 mm) and have a wall thickness less than 0.375 in. (9.53 mm), but are limited in depth to 0.375-in. (9.53-mm) maximum by another rigid surface shall be permissible (see Fig. 2). The product shall be evaluated in all manufacturer's recommended use positions. Holes and openings in surfaces that are in contact with the floor or are in the mattress support or below the mattress support are exempt from this requirement because they are deemed not accessible to the occupant or child on the outsides of the product.

5.17 *Scissoring, Shearing, or Pinching*—A product, when in the manufacturer's recommended use position, shall be designed and constructed to prevent injury to the occupant from any scissoring, shearing, or pinching when members or components rotate about a common axis or fastening point, slide, pivot, fold, or otherwise move relative to one another. Scissoring, shearing, or pinching that may cause injury shall not be permissible when the edges of the rigid parts admit a probe that is greater than 0.210 in. (5.30 mm) and less than 0.375 in. (9.50 mm) diameter at any accessible point throughout the range of motion of such parts. These requirements do not apply to the recognized and familiar hazards associated with the raising or closing action of moveable or foldable sides.

5.18 *Labeling*:

5.18.1 Paper warning labels shall be permanent when tested in accordance with 7.14.1.

5.18.2 Nonpaper labels shall not liberate small parts when tested in accordance with 7.14.2.

5.18.3 Warning labels attached by a seam shall be permanent when tested in accordance with 7.14.3.

5.18.4 Warning statements applied directly onto the surface of the product by hot stamping, heat transfer, printing, wood burning, etc. shall be permanent when tested in accordance with 7.14.4.

5.18.5 Storage pouch or other part with warning statements printed on it, excluding labels, shall be considered permanent if it cannot be removed when tested in accordance with 7.14.5.

5.19 *Cord/Strap Length*—No cord or strap made of a flexible material such as fabric, elastic, or plastic having a free stretched length in excess of 7.4 in. (188 mm) shall be attached to a product. Restraint straps that are attached to accessories

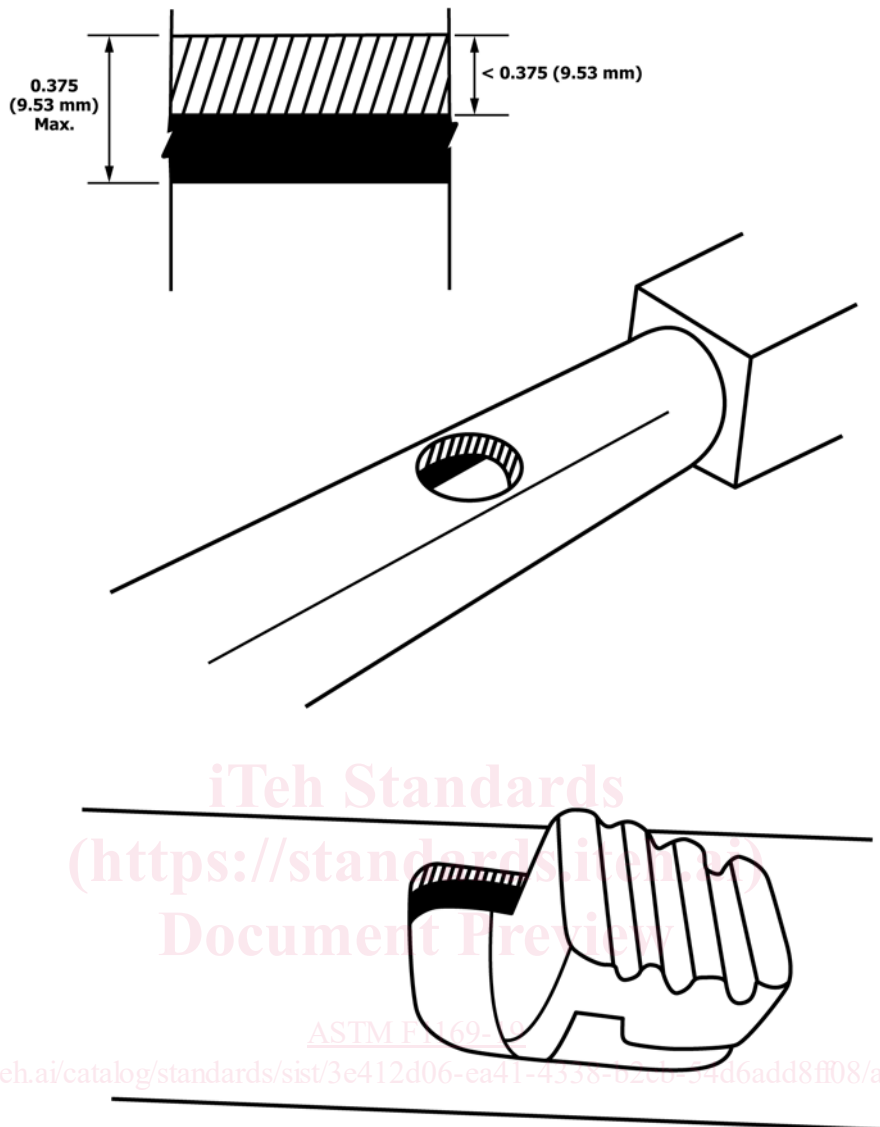

FIG. 2 Opening Example

outside of the occupant retention area shall only be evaluated for the length that can extend into the occupant retention area. Test in accordance with 7.13.

5.20 *Cribs that Fold for Storage or Transport*—Any unit that folds for storage or transport shall have a locking device or other provision in the design that will prevent the unit from unintentionally folding when properly placed in the manufacturer’s recommended use position.

5.20.1 During and upon completion of all testing, the unit shall remain in its manufacturer’s recommended use position.

5.20.2 If a unit is designed with a locking device:

5.20.2.1 That device shall remain engaged and operative after testing.

5.20.2.2 Each single-action locking device that is provided to prevent folding shall require a minimum force of 10 lbf (45 N) to activate the release mechanism when tested in accordance with 7.12.

6. Performance Requirements

6.1 *Plastic Teething Rail Test Requirement*—The feeler gage specified in 7.1.2.1 shall not enter any gap created by the deflection or deformation, or both, of the plastic teething rail resulting from the application of a 50-lbf (222-N) vertically downward force.

6.2 *Cycle Testing*—No crib shall exhibit structural failure, loosening of fasteners as defined in 6.2.1, damage to latching or locking mechanisms, or failure of latching or locking mechanisms when tested in accordance with the test methods in 7.2.

6.2.1 After testing in accordance with the procedure in 7.2, key structural elements attached by screws or threaded fasteners shall not have separated by more than 0.04 in. (1.00 mm) upon completion of testing.

6.3 *Crib Side Latch Test Requirements:*

6.3.1 The latching mechanism securing a moveable or folding side of a crib shall automatically engage when the side is placed in the normal use position.

6.3.2 The latching mechanism shall not disengage during the tests conducted in accordance with the procedure in 7.3.4 or 7.3.5 (whichever is appropriate), and shall continue to function in the intended manner upon completion of the tests.

6.3.3 Each single-action latching device that is provided to secure a moveable or folding side shall require a minimum force of 10 lbf (4.5 kg) to activate the release mechanism or shall consist of a double-action device requiring two distinct and separate actions for release.

6.4 *Mattress Support System Vertical Impact Test Requirements*—After testing in accordance with the procedure in 7.4, the crib shall comply with the requirements of Section 5. Key structural elements attached by screws shall not have separated by more than 0.04 in. (1.00 mm) upon completion of testing.

6.5 *Mattress Support System Test Requirement*—When tested in accordance with the procedure in 7.5, the mattress support system shall not detach from the crib at any point of attachment, or the force applied in 7.5.3.6 cannot be maintained for 10 s.

6.6 *Crib Side Test Requirements*—Each crib side containing spindles or slats shall be tested in accordance with the procedure in 7.6.

6.6.1 After completion of the cyclic and static portions of the side tests, the crib shall comply with the requirements of Section 5 and no spindles or slats shall have broken or completely separated from the top or bottom rail. Complete separation shall be determined by placing a right triangular prism shaped wedge (see Fig. 3) between two spindles or slats

adjacent to the rail from which these have separated and applying a 20-lbf (90-N) pull force to the wedge in a direction normal to the plane of the crib side. If a spindle or slat moves away from the hole in the rail in which it was formerly secured, complete separation has occurred.

6.6.2 Components attached by screws shall not have separated by more than 0.04 in. (1 mm) upon completion of testing.

6.6.3 Any spindles or slats that could be rotated during the torque test shall comply with the spacing of crib components of Section 5 when turned to their most adverse position.

6.7 *Spindle/Slat Strength Testing*—After testing in accordance with the procedure in 7.7, there shall be no complete breakage of any spindle/slat or complete separation of either end of a spindle/slat from the crib assembly's horizontal members when tested per 7.7.2 and 7.7.3 except as explained in 7.7.4. Any failure, as defined in this paragraph, when testing per 7.7.4 and 7.7.5 shall constitute a failure of the test. Audible indications during testing shall not constitute evidence of failure. After testing, the spacing between all adjacent intact spindles/slats shall comply with requirements of 5.8.2. Spacing between slats that have an intervening gap due to an allowable slat breakage shall not be evaluated for compliance with 5.8.2. Any resultant damage to the rail or slat, or both, arising from an allowed slat breakage, under subsection 7.7, shall not be evaluated for compliance with any other section of this standard.

6.8 *Cutouts*—Cribs shall comply with the requirements for cutouts when tested in accordance with the method outlined in 7.9.

6.9 *Entrapment in Accessories*—These requirements apply to accessories as defined in 3.1 that attach to or rest on a crib. (See Fig. 4 for an example of an accessory that attaches to the

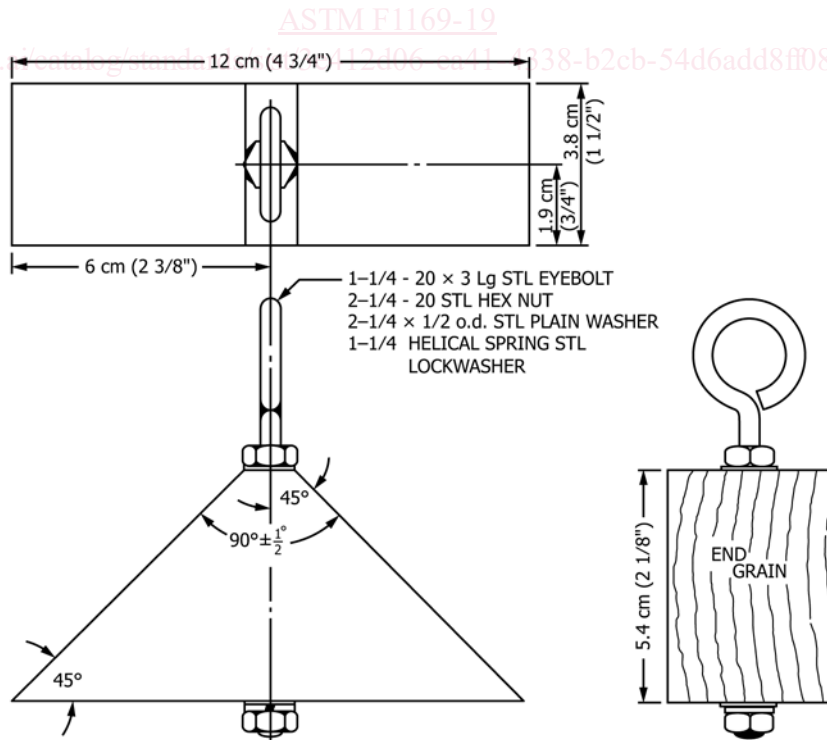

FIG. 3 Crib Slat Loading Wedge



FIG. 4 Example of Accessory Attached to Crib

crib on one side and has attachment points that rest on the crib on the other side.) This only applies to accessories in the occupant retention area.

6.9.1 When tested in accordance with the procedure in 7.10, openings shall not allow the complete passage of the small head probe shown in Fig. 5, unless they allow the complete passage of the large head probe shown in Fig. 6.

6.9.2 When tested in accordance with the procedure in 7.10, all attachment points shall remain attached and any opening exposed by the test shall not allow the complete passage of the small head probe shown in Fig. 5.

6.10 *Mattress Support System Openings*—There shall be no openings in the mattress support system that will permit complete passage of the wedge block described in Fig. 7 when tested in accordance with 7.11.

6.11 The performance testing requirements of this section shall be performed in the following order:

- (1) Teething rail test
- (2) Cyclic testing
- (3) Crib side latch testing
- (4) Mattress support system vertical impact testing
- (5) Mattress support system testing
- (6) Crib side testing
- (7) Slat/spindle strength test

7. Test Methods

7.1 *Plastic Teething Rail Test:*

7.1.1 *General*—This test consists of deforming the plastic teething rail under load to determine the security of the attachment.

7.1.2 *Apparatus for Plastic Teething Rail Test:*

7.1.2.1 *Feeler Gage*, 0.040 by 1 in. (1.00 by 25 mm).

7.1.2.2 *Hardwood Block*, with 2 by 2 in. (50 by 50 mm) contact area.

7.1.2.3 *Hardware*, to apply 50 lbf (222 N) to block.

7.1.3 *Procedure for Plastic Teething Rail Test:*

7.1.3.1 Install the teething rail per normal manufacturing practice.

7.1.3.2 With the plastic teething rail assembled to crib top rail, apply a 50-lbf (222-N) vertically downward force to the top of the teething rail through the hardwood block at the center top of the teething rail. While maintaining this force, determine if the 0.040 in. (1.00 mm) feeler gage can be inserted between the vertical surfaces of the top rail and the inside surface or edge of the plastic teething rail (see Fig. 8).

7.1.3.3 Repeat 7.1.3.2 at center location wherever a plastic teething rail is located.

7.2 *Dynamic Structural Tests:*

7.2.1 *Horizontal Cyclic Testing:*

7.2.1.1 The crib, including any accessories that are rigidly mounted to the crib, shall be assembled per the manufacturer's instructions except that any wheels or casters shall not be assembled. The testing in this section shall be conducted without casters. Items, such as drawers and hampers, when assembled in the manufacturer's recommended use positions, that are intended to move or slide and can be removed without the aid of tools shall be removed before testing.

7.2.1.2 The crib legs or base shall be restrained by an appropriate method to prohibit movement of the crib and shall

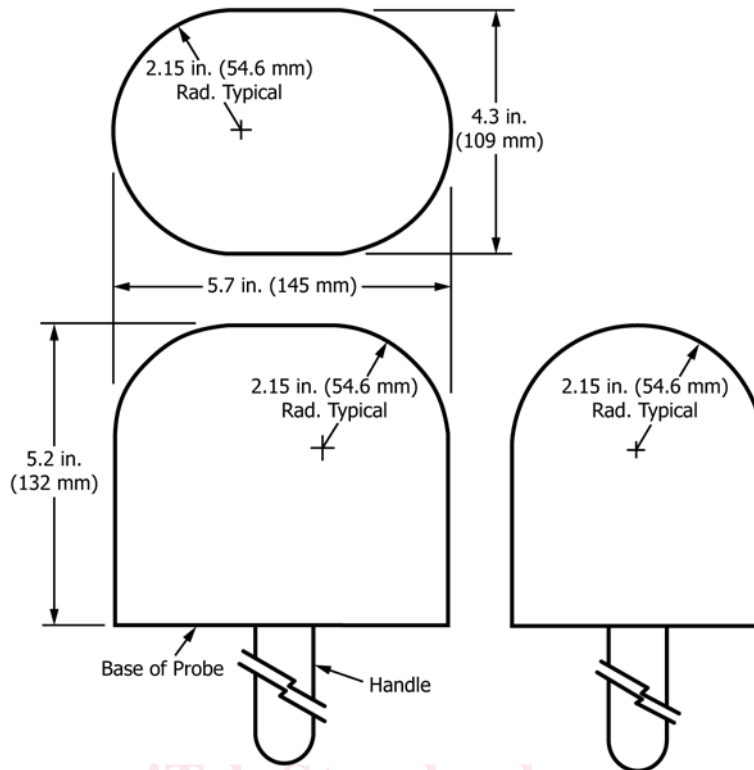

NOTE 1—Dimensions are based on a 5th percentile 6-month-old child. Gauge may be modified to facilitate testing to allow for pulling of the gauge.

FIG. 5 Small Head Probe

not impede the application of the load or deflection of the side being tested for all phases of this test procedure.

7.2.1.3 By any appropriate means, mark and note the position and condition of all key structural elements to support evaluation of 6.2.1.

7.2.1.4 Using a rigid frame structure and an appropriately designed apparatus, apply a cyclical horizontal load of 27 ± 2 lbf (120 ± 9 N) to the geometric center of the top of each side/end assembly at a point no more than 1 in. from the top of the rail on the assembly being tested. The force shall be applied to the crib through a rigid 2 in. (51 mm) wide clamping device in both the inward and outward directions, a cycle being defined as the application of the 27 lbf force in each direction. The frequency shall be no less than 155 ± 5 cycles per minute. The total number of cycles shall be 9000.

NOTE 1—An appropriately designed apparatus for applying the 27 lbf to the crib assembly must be designed to maintain the 27 lbf for the duration of the cycle testing. The resistance of the crib assembly may change with repeated cycling requiring a different deflection distance to achieve the constant application of 27 lbf.

7.2.1.5 Repeat the steps described in 7.2.1.3 and 7.2.1.4 for all remaining side/end assemblies of the crib without retightening any of the fasteners.

7.2.1.6 Inspect the crib and the fasteners to ensure compliance with 6.2.

7.2.2 Vertical Cyclic Testing:

7.2.2.1 The crib, including any accessories that are rigidly mounted to the crib, shall be assembled per the manufacturer's instructions except that any wheels or casters shall not be assembled. The testing in this section shall be conducted

without casters. Items, like drawers and hampers, when assembled in the manufacturer's recommended use positions, that are intended to move or slide and can be removed without the aid of tools shall be removed before testing.

7.2.2.2 The crib legs or base shall be restrained by an appropriate method to prohibit movement of the crib and shall not impede the application of the load or deflection of the side being tested for all phases of this test procedure.

7.2.2.3 By any appropriate means, mark and note the position and condition of all key structural elements to support evaluation of 6.2.1.

7.2.2.4 Using a rigid frame structure and an appropriately designed apparatus, apply a cyclical vertical load of 27 ± 2 lbf (120 ± 9 N) to the geometric center of the top of each side/end assembly at a point centered no more than 1 in. from the top of the rail on the assembly being tested. The force shall be applied to the crib through a rigid 2-in. (51-mm) wide clamping device in both the upward and downward directions, a cycle being defined as the application of the 27 lbf force in each direction. The frequency shall be no less than 155 ± 5 cycles per minute. The total number of cycles shall be 9000.

NOTE 2—An appropriately designed apparatus for applying the 27 lbf to the crib assembly must be designed to maintain the 27 lbf for the duration of the cycle testing. The resistance of the crib assembly may change with repeated cycling requiring a different deflection distance to achieve the constant application of 27 lbf.

7.2.2.5 Repeat the steps in 7.2.2.3 and 7.2.2.4 for all remaining assemblies of the crib without retightening any of the fasteners.

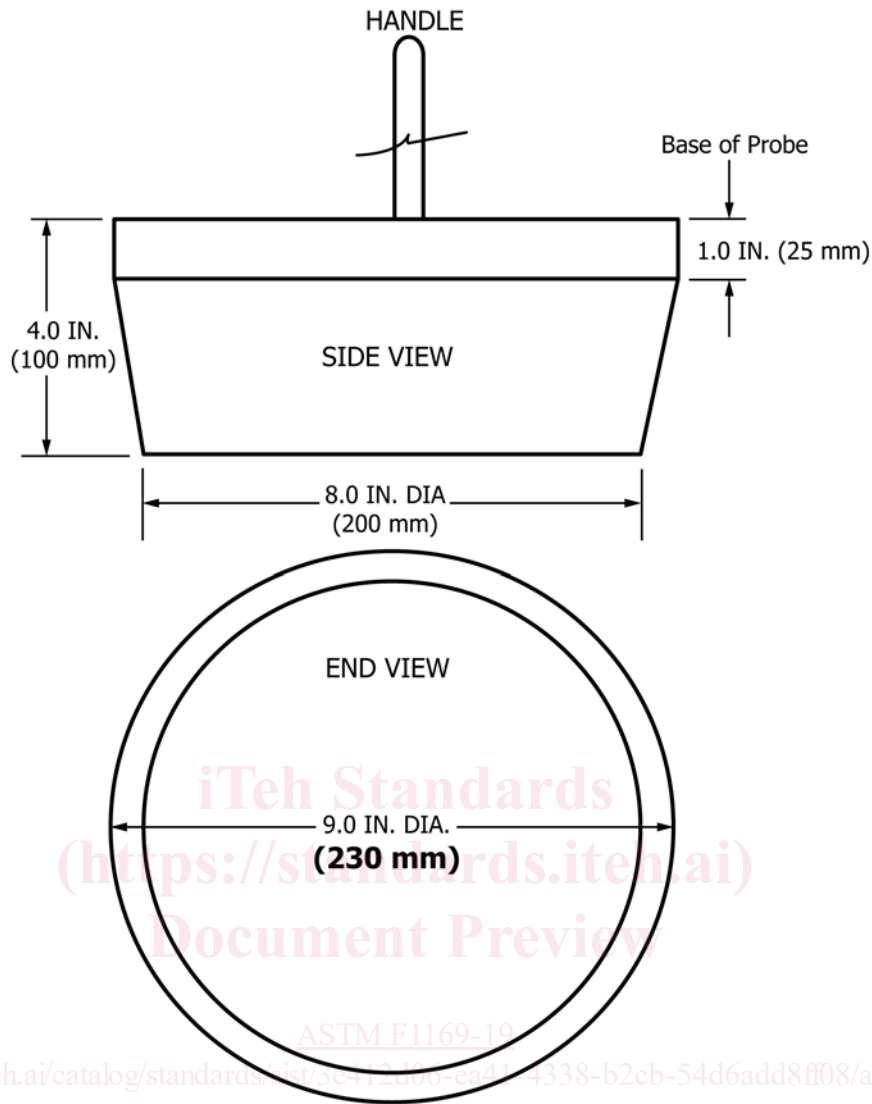

NOTE 1—The 9.0 in. diameter is based on the back-of-head to tip-of-chin dimension for a 97th percentile 3-year old.
FIG. 6 Large Head Probe

7.2.2.6 Inspect the crib and the fasteners to ensure compliance with 6.2.

7.3 Crib Side Latch Test:

7.3.1 *General*—This test assists in evaluating the integrity of the crib side latching system under abusive load conditions. The test applies a force to a movable/folding crib side in a direction tending to cause latch failure while a horizontal force is applied parallel to the major axis of the crib.

7.3.2 Apparatus for Crib Side Latch Test:

7.3.2.1 Hardwood block with a contact area of 2 by 2 in. (50 by 50 mm) for distribution of applied loads.

7.3.3 Procedure for Crib Side Latch Test:

7.3.3.1 Casters shall not be installed on crib. Secure the bottom of the crib in a manner that will prevent horizontal motion.

7.3.4 Moveable Side Latch Test:

7.3.4.1 Gradually apply within 5 s a vertically downward force of 60 lbf (270 N) through a hardwood block with a 2 by 2 in. (50 by 50 mm) contact area to the upper horizontal rail of

the crib side at a point that is 6 in. (150 mm) from one end of the rail. While the 60-lbf (270-N) downward force is applied to the crib side, gradually apply within 5 s a 30-lbf (133-N) horizontal force in a direction parallel to the moveable side. The point of application of this force shall be in the plane of the moveable side and 1 in. (25 mm) down from the top of the crib corner post (or crib end panel for construction not incorporating crib corner posts (see Fig. 9). Maintain this horizontal force for 30 s then reverse its direction and maintain it for an additional 30 s.

7.3.4.2 Repeat this procedure at the other end of the crib moveable side and, if the crib has more than one moveable side, perform the test at each end of each moveable side.

7.3.4.3 Upon completion of the test, release the moveable side latch and lower the crib side. Then raise the side and observe whether the latch automatically engages in the manner intended by the manufacturer.

7.3.5 Folding Side Latch Test:

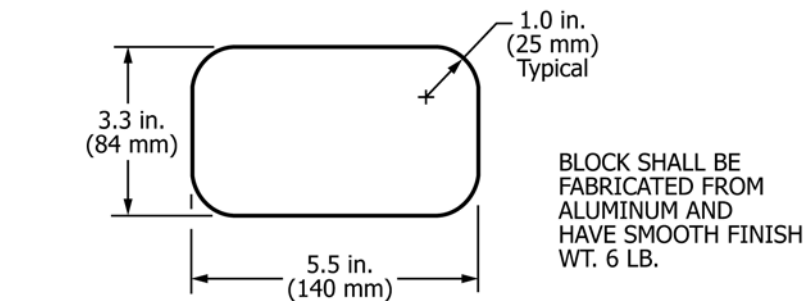

FIG. 7 Wedge Block

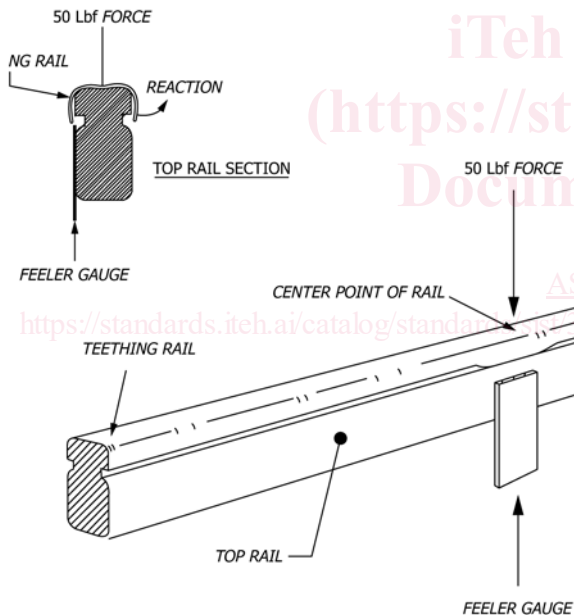
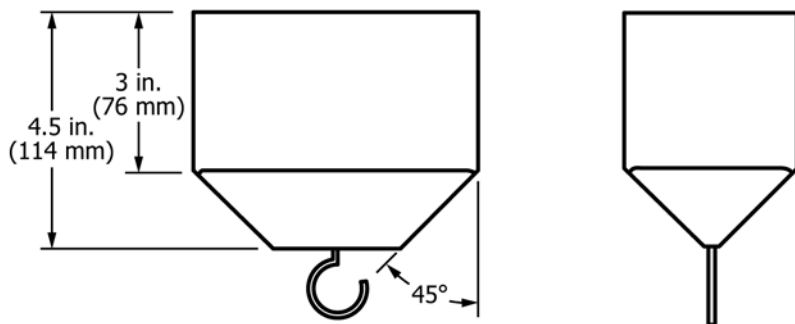

FIG. 8 Teething Rail Test

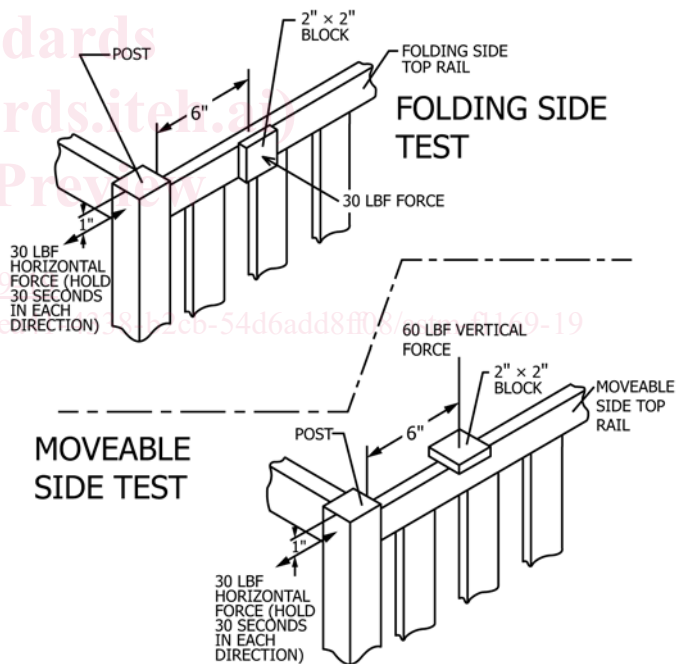

FIG. 9 Crib Side Latch Test

7.3.5.1 Place the folding side in the latched position. Through a hardwood block with contact area of 2 by 2 in. (50 by 50 mm), gradually apply within 5 s a force of 30 lbf (133-N) horizontally outward, perpendicular to, and at a point that is 6 in. (150 mm) from one end of the folding side upper rail. While this 30-lbf (133-N) force is applied to the crib side, gradually apply within 5 s a 30-lbf (133-N) horizontal force in a direction parallel to the folding side. The point of application of this force shall be in the plane of the folding side and 1 in. (25 mm) down from the top of the crib corner post (or crib end panel for construction not incorporating crib corner posts—see Fig. 9).

Maintain this horizontal force for 30 s then reverse its direction and maintain it for an additional 30 s.

7.3.5.2 Place the folding side in the latched position. Through a hardwood block with contact area of 2 by 2 in. (50 by 50 mm), gradually apply within 5 s a force of 30 lbf (133-N) horizontally inward, perpendicular to, and at a point that is 6 in. (150 mm) from one end of the folding side upper rail. While this 30-lbf (133-N) force is applied to the crib side, gradually apply within 5 s a 30-lbf (133-N) horizontal force in a direction parallel to the folding side. The point of application of this