



Designation: F1967 – 19

Standard Consumer Safety Specification for Infant Bath Seats¹

This standard is issued under the fixed designation F1967; the number immediately following the designation indicates the year of original adoption or, in the case of revision, the year of last revision. A number in parentheses indicates the year of last reapproval. A superscript epsilon (ϵ) indicates an editorial change since the last revision or reapproval.

INTRODUCTION

This consumer safety specification is intended to address certain incidents associated with the use of bath seats, bath rings, and other similar devices.

The U.S. Consumer Product Safety Commission (CPSC) identified drowning incidents which generally involved infants either tipping over, climbing out of, or sliding through the product after being left unattended by their caregiver.

This specification does not address incidents in which bath seats are unreasonably misused, are used in a careless manner that disregards the warnings and instructions that are provided with each product, or those instances where the caregiver leaves the infant unattended in the product.

This consumer safety specification is written within the current state-of-the-art product technology. It is intended that this specification will be updated whenever substantive information becomes available and known to ASTM which necessitates additional requirements or justifies the revision of existing requirements.

1. Scope

1.1 This consumer safety specification establishes performance requirements, test methods, and labeling requirements to promote the safe use of infant bath seats. Products commonly referred to as bath rings also are included in the scope of this specification. Traditional infant bath tubs that are used to bathe an infant are not within the scope of this standard.

1.2 This consumer safety specification is intended to reduce the risk of death and minimize injury to infants resulting from use and reasonably foreseeable abuse of infant bath seats.

1.3 No infant bath seat produced after the approval date of this consumer safety specification shall, either by label or other means, indicate compliance with this specification unless it conforms to all requirements contained herein.

1.4 The values stated in inch-pound units are to be regarded as standard. The values given in parentheses are mathematical conversions to SI units that are provided for information only and are not considered standard.

1.5 The following precautionary caveat pertains only to the test methods portion, Section 7, of this specification: *This standard does not purport to address all of the safety concerns,*

if any, associated with its use. It is the responsibility of the user of this standard to establish appropriate safety, health, and environmental practices and determine the applicability of regulatory limitations prior to use.

1.6 *This international standard was developed in accordance with internationally recognized principles on standardization established in the Decision on Principles for the Development of International Standards, Guides and Recommendations issued by the World Trade Organization Technical Barriers to Trade (TBT) Committee.*

2. Referenced Documents

2.1 *ASTM Standards:*²

[D3359 Test Methods for Rating Adhesion by Tape Test](#)

[F404 Consumer Safety Specification for High Chairs](#)

[F963 Consumer Safety Specification for Toy Safety](#)

[F977 Consumer Safety Specification for Infant Walkers](#)

2.2 *Federal Regulations:*³

[16 CFR 1303 Ban of Lead-Containing Paint and Certain Consumer Products Bearing Lead Containing Paint](#)

[16 CFR 1500 Federal Hazardous Substances Act Regulations, including sections:](#)

¹ This consumer safety specification is under the jurisdiction of ASTM Committee F15 on Consumer Products and is the direct responsibility of Subcommittee F15.20 on Bath Seats.

Current edition approved May 1, 2019. Published May 2019. Originally approved in 1999. Last previous edition approved in 2018 as F1967 – 18. DOI: 10.1520/F1967-19.

² For referenced ASTM standards, visit the ASTM website, www.astm.org, or contact ASTM Customer Service at service@astm.org. For *Annual Book of ASTM Standards* volume information, refer to the standard's Document Summary page on the ASTM website.

³ Available from U.S. Government Printing Office Superintendent of Documents, 732 N. Capitol St., NW, Mail Stop: SDE, Washington, DC 20401.

16 CFR 1500.48 Technical Requirements for Determining a Sharp Point in Toys and Other Articles Intended for Use by Children Under 8 Years of Age

16 CFR 1500.49 Technical Requirements for Determining a Sharp Metal or Glass Edge in Toys and Other Articles Intended for Use by Children Under 8 Years of Age

16 CFR 1501 Method for Identifying Toys and Other Articles Intended for Use by Children Under 3 Years of Age Which Present Choking, Aspiration, or Ingestion Hazards Because of Small Parts

Consumer Product Safety Improvement Act

2.3 *ANSI Standards*:⁴

ANSI Z535.1 Safety Colors

ANSI Z535.4 Product Safety Signs and Labels

ANSI Z535.6 Product Safety Information in Product Manuals, Instructions, and Other Collateral Materials

3. Terminology

3.1 *Definitions of Terms Specific to This Standard:*

3.1.1 *bath seat, n*—an article that is used in a bath tub, sink, or similar bathing enclosure and that provides support, at a minimum, to the front and back of a seated infant during bathing by a caregiver. This does not include products that are designed or intended to retain water for bathing.

3.1.2 *conspicuous, adj*—visible, when the product is in all manufacturer’s recommended use positions and an occupant is sitting in the product, to an adult caregiver near the product at any one position around the product but not necessarily visible from all positions.

3.1.3 *double action release system, n*—a mechanism requiring either two consecutive actions, the first of which must be maintained while the second is carried out, or two separate and independent simultaneous actions to fully release.

3.1.4 *installation components, n*—components of the infant bath seat that provide the means of installation to the adult bath tub, including, but not limited to, clamps, arms, suction cups, and pads.

3.1.5 *locking and latching mechanism, n*—method of preventing a bath seat from folding or collapsing during use.

3.1.6 *manufacturer’s recommended use position(s), n*—any position that is presented as a normal, allowable, or acceptable configuration for the use of the product by the manufacturer in any descriptive or instructional literature. This specifically excludes positions which the manufacturer shows in a like manner in its literature to be unacceptable, unsafe or not recommended.

3.1.7 *nonpaper label, n*—any label material, such as plastic or metal, that either will not tear without the aid of tools or tears leaving a sharply defined edge or labels made of fabric.

3.1.8 *occupant, n*—infant that is in an infant bath seat in any manufacturer’s recommended use position(s).

3.1.9 *paper label, n*—any label material that tears without the aid of tools and leaves a fibrous edge.

3.1.10 *principal display panel, n*—that part of the product’s package that is most likely to be displayed, presented, shown or examined under normal or customary conditions of display for retail sale.

3.1.11 *protective component, n*—any component used for protection from sharp edges, points, or entrapment of fingers or toes.

3.1.11.1 *Discussion*—Examples of protective components include caps, sleeves, and plugs.

3.1.12 *stability, n*—ability of a bath seat to remain upright in all of the manufacturer’s recommended use positions.

3.1.13 *static load, n*—vertically downward load applied by weights or other means.

4. Calibration and Standardization

4.1 Unless otherwise noted, the bath seat shall be completely assembled in accordance with the manufacturer’s instructions.

4.2 The product to be tested shall be in a room with an ambient temperature of $73 \pm 9^\circ\text{F}$ ($23 \pm 5^\circ\text{C}$) for at least 1 h prior to testing. Testing then shall be conducted within this temperature range.

4.3 All testing required by this specification shall be conducted on the same unit.

5. General Requirements

5.1 *Hazardous Sharp Edges or Points*—There shall be no hazardous sharp points or edges as defined in 16 CFR 1500.48 and 16 CFR 1500.49 before or after the product has been tested to this consumer safety specification.

5.2 *Small Parts*—There shall be no small parts as defined in 16 CFR 1501 before testing or liberated as a result of testing to this consumer safety specification.

5.3 *Lead in Paints*—All paint and surface coatings on the product shall comply with the requirements of 16 CFR 1303.

5.4 Latching and Locking Mechanisms:

5.4.1 Products that fold shall have a latching and locking mechanism or other means to prevent collapse of the product when it is installed in any manufacturer’s recommended use position(s).

5.4.2 During and upon completion of the test in accordance with 7.1.1, the product shall remain in the manufacturer’s recommended use position, and the latching and locking mechanism shall remain engaged and operative.

5.4.3 Products designed with a latching and locking mechanism shall comply with either 5.4.3.1 or 5.4.3.2.

5.4.3.1 Product shall be designed with a single action release mechanism that shall not release when tested in accordance with 7.1.2.

5.4.3.2 Product shall be designed with a double action release system.

5.4.4 Latching and locking mechanisms shall also comply with all requirements in 5.4 after cycling has been conducted in accordance with 7.1.3.

5.5 *Scissoring, Shearing, and Pinching*—The product, when in the manufacturer’s recommended use position(s), shall be

⁴ Available from American National Standards Institute (ANSI), 25 W. 43rd St., 4th Floor, New York, NY 10036, <http://www.ansi.org>.

designed and constructed to prevent injury to the occupant from any scissoring, shearing, or pinching when members or components rotate about a common axis or fastening point, slide, pivot, fold or otherwise move relative to one another. Scissoring, shearing, or pinching that may cause injury exists when the edges of the rigid parts admit a probe greater than 0.210 in. (5.33 mm) and less than 0.375 in. (9.53 mm) in diameter at any accessible point throughout the range of motion of such parts.

5.6 *Openings*—Holes or slots that extend entirely through a wall section of any rigid material less than 0.375-in. (9.53-mm) thick and admit a 0.210-in. (5.33-mm) diameter rod shall also admit a 0.375-in. (9.53-mm) diameter rod. Holes or slots that are between 0.210 in. (5.33 mm) and 0.375 in. (9.53 mm) and have a wall thickness less than 0.375 in. (9.53 mm) but are limited in depth to 0.375 in. (9.53 mm) maximum by another rigid surface shall be permissible (see Fig. 1 for examples). The product shall be evaluated in all manufacturer’s recommended use positions.

5.7 *Protective Components*—If the child can grasp protective components between the thumb and forefinger, or teeth, or if there is at least a 0.04 in. (1.0 mm) gap between the component and its adjacent parent component, such component shall not be removed when tested in accordance with 7.2.

5.8 *Requirements for Toys*—Toy accessories attached to, removable from, or sold with infant bath seats, as well as their means of attachment, shall comply with the applicable requirements of Standard Consumer Safety Specification F963.

5.9 *Labeling:*

5.9.1 Warning labels, whether paper or nonpaper, shall be permanent when tested in accordance with 7.3.1 – 7.3.4.

5.9.2 Warning statements applied directly onto the surface of the product by hot stamping, heat transfer, printing, wood burning, etc. shall be permanent when tested in accordance with 7.3.1 and 7.3.5.

5.9.3 Nonpaper labels shall not liberate small parts when tested in accordance with 7.3.6.

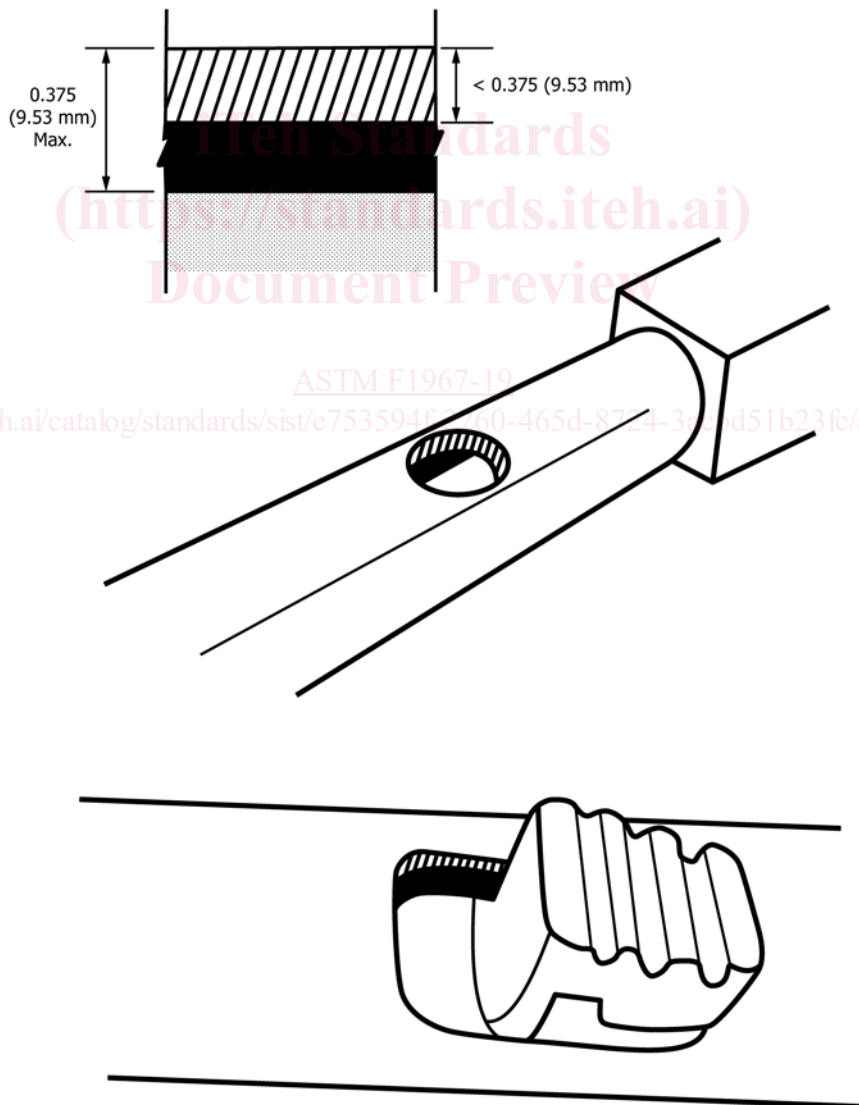

FIG. 1 Opening Examples

5.10 Infant bath seats must comply with the applicable requirements of the Consumer Product Safety Improvement Act.

6. Performance Requirements

6.1 Stability:

6.1.1 The stability test shall be conducted after the Mechanisms Durability test in 7.1.3.

6.1.2 During and after testing in accordance with 7.4, the product shall comply with the following:

6.1.2.1 No parts of the product shall become separated from it.

6.1.2.2 The product shall not sustain permanent damage.

6.1.2.3 The product shall not tip over. If the product would continue to tip over under the application of force, but it is prevented from doing so by the test platform interior side walls, it shall be considered a tip over.

6.1.2.4 No attachment point shall disengage from (is no longer in contact with) the test platform and then fail to return to its manufacturer's recommended use position.

6.1.2.5 At all time during the application of force, the seat shall remain in its initial position and shall not be tilted at an angle of 12° or more from its initial position.

6.2 Restraint System:

6.2.1 Bath seats, when in the manufacturer's recommended use position(s), must provide a passive crotch restraint and comply with 6.2.1.1. The bath seat shall not include any additional restraint system which requires action on the part of the caregiver to secure the restraint.

6.2.1.1 A passive crotch restraint shall be assembled as part of the bath seat before shipment from the manufacturer or shall be designed such that the bath seat cannot be used without the passive crotch restraint in place. The passive crotch restraint shall be permanently attached to the bath seat.

6.3 *Static Load*—The product shall not break, become permanently deformed or damaged, or fail to comply with any of the other requirements of this specification when tested in accordance with 7.5.

6.4 *Specific Requirements for Suction Cups*—Products that utilize suction cups as a method of attachment to the bathing surface shall comply with the following requirements:

6.4.1 Each suction cup shall remain attached to the product and shall not become damaged or broken after testing in accordance with 7.6.1.

6.4.2 The product shall attach and remain attached to each test surface and shall not become damaged or broken after testing in accordance with 7.6.2.

6.5 Leg Openings:

6.5.1 All openings on the sides of the product through which a seated occupant can slide or otherwise insert any extremity shall not permit the passage of the Bath Seat Torso Test Probe when tested in accordance with 7.7.1.

6.5.2 When these same openings are tested in accordance with 7.7.2, the 1.0 in. (25 mm) perimeter of the Bath Seat Shoulder Test Probe at the shoulder breadth end shall not be permitted to contact the seating surface of the product.

6.6 *Installation Components*—Prior to shipment, all components required for the proper installation and use of the product according to the manufacturer's instructions in all manufacturer's recommended use positions shall be permanently attached to the product. Permanently attached shall mean that such components cannot be removed from the product without the use of a tool.

7. Test Methods

7.1 Latching and Locking Mechanism Tests:

7.1.1 Resistance to Collapse:

7.1.1.1 Install the product with the latching and locking mechanism(s) engaged in one of the manufacturer's recommended use positions on Test Surface #2 or Test Surface #3, or both, depending on the manufacturer's installation instructions (refer to Stability Test Method for test surface specification). Secure the product to the test surface(s) so that any collapsing motion is not impeded.

7.1.1.2 Gradually apply a 45 lbf (200 N) force to the product in the direction normally associated with collapsing the product.

7.1.1.3 Repeat this procedure four additional times within a 2-min period.

7.1.1.4 Submerge the product in enough clear water to fully cover the latching and locking mechanism. Water shall be at an initial temperature of 100 to 105°F (37.8 to 40.6°C).

7.1.1.5 Repeat 7.1.1.1 through 7.1.1.3 while maintaining the product in its submerged position.

7.1.1.6 Repeat the testing in both the dry and the submerged conditions for all other manufacturer's recommended use positions.

7.1.2 Single Action Release Mechanism Test:

7.1.2.1 Install the product in one of the manufacturer's recommended use positions on Test Surface #2 or Test Surface #3, or both (refer to Stability Test Method for test surface specification). Secure the product so that any collapsing motion is not impeded.

7.1.2.2 Gradually apply a 10 lbf (45 N) force to the locking and latching mechanism in the direction tending to release it.

7.1.2.3 Repeat 7.1.2.1 and 7.1.2.2 for all other manufacturer's recommended use positions.

7.1.3 *Latching and Locking Mechanism Durability Test*—All latching and locking mechanism(s) shall be cycled through their normal operation a total of 2000 cycles. Each cycle shall consist of opening and closing the mechanism(s) and erecting/folding the product. Cycling shall be conducted on a continuous basis.

7.2 Removal of Protective Components Test:

7.2.1 Prior to conducting the following tests, first completely submerge the testable components for 20 min in clear water that is at an initial temperature of 100 to 105°F (37.8 to 40.6°C). Conduct the following tests within 10 min after removal from the water.

7.2.2 Any protective component shall be tested in accordance with each of the following methods in the sequence listed.

7.2.3 Secure the product so that the product cannot move during the performance of the following tests:

7.2.4 *Torque Test*—Gradually apply a torque of 4 lbf-in. (0.4 N-m) over a period of 5 s in a clockwise direction until a rotation of 180° from the original position has been attained or 4 lbf-in. has been exceeded. The torque or maximum rotation shall be maintained for an additional 10 s. The torque shall then be removed and the test components permitted to return to a relaxed condition. This procedure shall then be repeated in the counter-clockwise direction.

7.2.5 *Tension Test:*

7.2.5.1 Attach a force gauge to the protective component by means of any suitable device. For components that cannot reasonably be expected to be grasped between thumb and forefinger, or teeth, on their outer diameter but have a gap of 0.04 in. (1.0 mm) or more between the rear surface of the component and the structural member of the product to which they are attached, a clamp such as shown in Fig. 2 may be a suitable device.

7.2.5.2 Be sure that the attachment device does not compress or expand the component hindering any possible removal.

7.2.5.3 Gradually apply a 15 lbf (67 N) force over a period of 5 s in the direction that would normally be associated with the removal of the protective component. Hold for an additional 10 s.

7.3 *Permanence of Labels and Warnings:*

7.3.1 To determine the permanence of a label or printing applied to the surface of the product, first completely submerge the label or printed area for 20 min in clear water that is at an initial temperature of 100 to 105°F (37.8 to 40.6°C). Drain off the excess water and let the label or printed area air dry for 24 h at 73 ± 9°F (23 ± 5°C), 20 to 70 % RH, prior to conducting any permanency tests.

7.3.2 A paper label (excluding labels attached by a seam) shall be considered permanent if, during an attempt to remove it without the aid of tools or solvents, it cannot be removed, it tears into pieces upon removal or such action damages the surface to which it is attached.

7.3.3 A nonpaper label (excluding labels attached by a seam) shall be considered permanent if, during an attempt to remove it without the aid of tools or solvents, it cannot be removed or such action damages the surface to which it is attached.

7.3.4 A warning label attached by a seam shall be considered permanent if it does not detach when subjected to a 15-lbf (67-N) pull force applied in any direction using a 3/4-in. diameter clamp surface.

7.3.5 Adhesion test for warnings applied directly onto the surface of the product.

7.3.5.1 Apply the tape test defined in Test Method B, Cross-Cut Tape Test of Test Methods D3359, eliminating parallel cuts.

7.3.5.2 Perform this test once in each different location where warnings are applied.

7.3.5.3 The warning statements will be considered permanent if the printing in the area tested is still legible and attached after being subjected to this test.

7.3.6 A nonpaper label, during an attempt to remove it without the aid of tools or solvents, shall not be removed or shall not fit entirely within the small parts cylinder defined in 16 CFR 1501 if it can be removed.

7.4 *Stability Test:*

7.4.1 *Test Equipment:*

7.4.1.1 *Test Platform*—Refer to Fig. 3, Fig. 4, and Fig. 5 for the specifications of an adult bath tub to be used as the test platform. All surfaces of this tub shall be smooth porcelain enamel. The side ledge of the tub shall be of uniform thickness of 4 ± 0.5 in. (10.2 ± 0.6 cm) for at least 24 in. (60.0 cm) along the length of the tub.⁵

7.4.1.2 *Test Surface Usage*—The test surface(s) described below to be used for required tests shall be determined by considering all of the attachment configurations and contact locations a given product utilizes to provide support and stability for the product in or on an adult bath tub. The stability test shall be conducted using all relevant surfaces, and multiple surfaces may be used either separately or simultaneously for testing, depending upon the manufacturer’s recommended installation instructions and use position(s).

(1) *Test Surface #1*—Any area on the bottom surface of the test platform where safety tread strips are applied as described below.

(2) *Test Surface #2*—Any area on the bottom surface of the test platform where safety tread strips are not applied.

(3) *Test Surface #3*—Any area on the side(s) of the test platform (for example, inside surface, outside surface, and top ledge), where safety tread strips are not applied.

NOTE 1—One test platform may be used for all test surfaces if sufficient

15 lb Max TENSION



FIG. 2 Tension Test Adapter/Clamp

⁵ At the time of original publication of this standard, the sole source of supply of the apparatus known to the committee was American Standard, 1 Centennial Plaza, Piscataway, NJ 08855-6820.

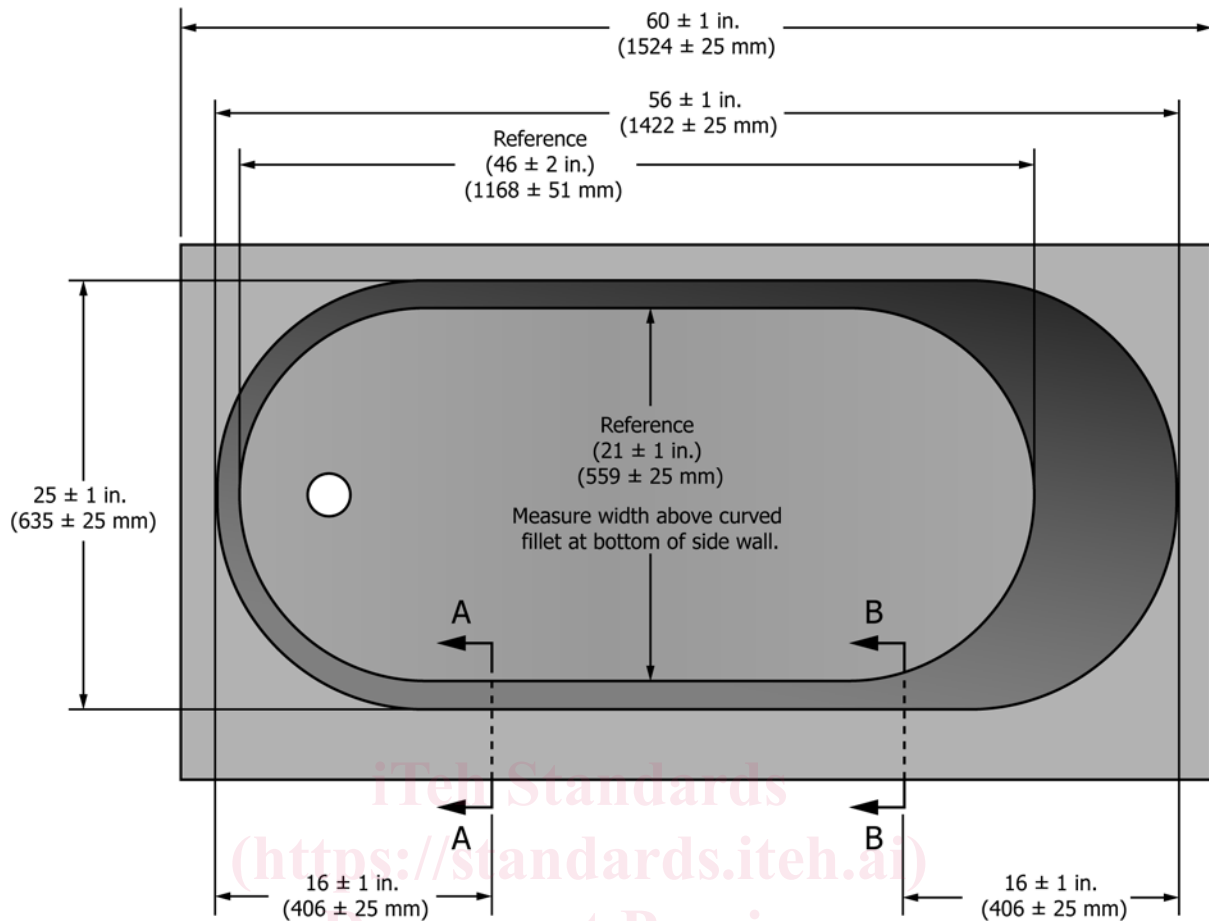

FIG. 3 Test Platform Top View

space allows for the use of all coverage areas as specified below.

7.4.1.3 *Coverage Area*—Any area where the product can be installed per the manufacturer’s instructions on Test Surfaces #1, #2 and #3, and that is at least 1 in. (25 mm) larger in all directions than the perimeter outlined by any part of the product that is designed to contact any of these surfaces.

NOTE 2—Each test surface requires an adequate coverage area.

7.4.1.4 *Safety Tread Strips*—Commercially available adhesive backed safety tread strips for bath tub use that are rectangular, approximately 0.75 in. (19 mm) wide by 7 in. (180 mm) or greater in length. The corners may be filleted with a radius that does not exceed ½ the width.

7.4.1.5 *Baby Wash Test Solution*—Any of the following products diluted in a 1 to 25 ratio of distilled water, and contained in a spray bottle:

- (a) Solution comprised of ingredients as shown in Table 1,
- or
- (b) Johnson’s baby head-to-toe baby wash, or
- (c) Aveeno baby wash and shampoo.

7.4.1.6 *Inclinometer* with a measurement tolerance of less than or equal to 0.5°. The maximum weight of the inclinometer and the fastening method shall be ≤2.2 lb (1 kg).

7.4.1.7 *Test Bar*—A 1 in. by ¼ in. (25 mm by 6 mm) rigid aluminum flat bar. The length of the test bar shall be such that it extends beyond the uppermost edge or surface of the product at least as far as the maximum distance *D* as calculated below plus enough additional length to accommodate the attachment of the inclinometer as described below.

7.4.2 *Test Surface #1 Preparation:*

7.4.2.1 Determine the coverage area for a product that contacts or attaches to the bottom surface of an adult bath tub for its support and stability. Clean the coverage area with any commercial cleaner intended for bath tubs, following the cleaner’s instructions. Then wipe the coverage area with alcohol and allow to dry.

7.4.2.2 Apply the safety tread strips evenly onto the coverage area at a distance of 0.375 ± 0.125 in. (9.5 ± 3 mm) apart from edge to edge.

7.4.2.3 Safety tread strips shall be replaced if they become damaged or dislodged from their specified position(s).

NOTE 3—The installation of the safety tread strips for Test Surface #1 will most likely need to be done only during the initial setup of this test surface, except for replacements that may be necessary from time to time.

7.4.3 *Test Protocol for Test Surface #1:*