



# Standard Specification for Chlorinated Poly(Vinyl Chloride)/Aluminum/Chlorinated Poly(Vinyl Chloride) (CPVC-AL-CPVC) Composite Pressure Tubing<sup>1</sup>

This standard is issued under the fixed designation F2855; the number immediately following the designation indicates the year of original adoption or, in the case of revision, the year of last revision. A number in parentheses indicates the year of last reappraisal. A superscript epsilon ( $\epsilon$ ) indicates an editorial change since the last revision or reappraisal.

## 1. Scope\*

1.1 This specification covers a Chlorinated Poly(Vinyl Chloride)/Aluminum/Chlorinated Poly(Vinyl Chloride), (CPVC AL CPVC), composite pressure tubing with a welded aluminum tube reinforcement between the inner and outer layers. The inner and outer CPVC layers are bonded to the aluminum tube by a melt adhesive. Included is a system of nomenclature for the composite tubing, the requirements and test methods for materials, the dimensions of the component layers and finished tubing, adhesion tests, hydrostatic burst and sustained pressure and thermocycling performance. Also given are the requirements and methods of marking. The components covered by this specification are intended for use in residential and commercial, hot and cold, potable water distribution systems.

NOTE 1—The text of this standard references notes and footnotes which provide explanatory material. These notes and footnotes (excluding those in tables and figures) shall not be considered as requirements of the standard.

1.2 This specification covers only composite tubing incorporating a continuously welded aluminum tube. Tubing consisting of metallic layers not continuously welded together are outside the scope of this specification.

1.3 Specifications for internal bushings for use with composite tubing meeting the requirements of this specification are given in [Annex A1](#).

NOTE 2—In order to assure the expected life expectancy of CPVC-AL-CPVC composite tubing by preventing corrosion of the Aluminum, a bushing meeting the requirements of [Annex A1](#) is required to be solvent cemented into the cut ends of the CPVC-AL-CPVC tubing prior to making solvent cement joints in the piping. This bushing seals off the cut ends of the tubing preventing any contact of the AL layer with any liquids being transported by the tubing.

1.4 Tubing meeting the requirements of this standard are designed to be used with fittings and solvent cements meeting the requirements of Specification [D2846/D2846M](#) when assembled in accordance with [Appendix X3](#) [Annex A2](#). **Warning—**Pressurized (compressed) air or other compressed gases contain large amounts of stored energy which present serious safety hazards should a system fail for any reason.

1.5 The products covered by this specification are intended for use with the distribution of pressurized liquids only, which are chemically compatible with the tubing materials. Due to inherent hazards associated with testing components and systems with compressed air or other compressed gases some manufacturers do not allow pneumatic testing of their products. Consult with specific product manufacturers for their specific testing procedures prior to pneumatic testing.

NOTE 3—Pressurized (compressed) air or other compressed gases contain large amounts of stored energy which present serious safety hazards should a system fail for any reason.

1.6 The values stated in inch-pound units are to be regarded as standard. The values given in parentheses are mathematical conversions to SI units that are provided for information only and are not considered standard.

NOTE 2—Suggested hydrostatic design pressures and pressure ratings for tubing are listed in [Appendix X1](#).

1.7 The following safety hazards caveat pertains only to the test method portion, Section 9. *This standard does not purport to address all of the safety concerns, if any, associated with its use. It is the responsibility of the user of this standard to establish appropriate safety and health practices and determine the applicability of regulatory limitations prior to use.*

<sup>1</sup> This specification is under the jurisdiction of ASTM Committee [F17](#) on Plastic Piping Systems and is the direct responsibility of Subcommittee [F17.61](#) on Water. Current edition approved April 1, 2012/April 1, 2019. Published May 2012/April 2019. Originally approved in 2011. Last previous edition approved in 2012 as F2855-11-12. DOI: 10.1520/F2855-12.10.1520/F2855-19.

\*A Summary of Changes section appears at the end of this standard

1.8 *This international standard was developed in accordance with internationally recognized principles on standardization established in the Decision on Principles for the Development of International Standards, Guides and Recommendations issued by the World Trade Organization Technical Barriers to Trade (TBT) Committee.*

## 2. Referenced Documents

### 2.1 ASTM Standards:<sup>2</sup>

**D696** Test Method for Coefficient of Linear Thermal Expansion of Plastics Between –30°C and 30°C with a Vitreous Silica Dilatometer

**D1600** Terminology for Abbreviated Terms Relating to Plastics

**D1784** Specification for Rigid Poly(Vinyl Chloride) (PVC) Compounds and Chlorinated Poly(Vinyl Chloride) (CPVC) Compounds

**D1898** Practice for Sampling of Plastics (Withdrawn 1998)<sup>3</sup>

**D2122** Test Method for Determining Dimensions of Thermoplastic Pipe and Fittings

**D2837** Test Method for Obtaining Hydrostatic Design Basis for Thermoplastic Pipe Materials or Pressure Design Basis for Thermoplastic Pipe Products

**D2846/D2846M** Specification for Chlorinated Poly(Vinyl Chloride) (CPVC) Plastic Hot- and Cold-Water Distribution Systems

**D3167** Test Method for Floating Roller Peel Resistance of Adhesives

**E8/E8M** Test Methods for Tension Testing of Metallic Materials

**F412** Terminology Relating to Plastic Piping Systems

**F1281** Specification for Crosslinked Polyethylene/Aluminum/Crosslinked Polyethylene (PEX-AL-PEX) Pressure Pipe

### 2.2 Federal Standards:<sup>4</sup>

**Fed. Std. No. 123** Marking for Shipments (Civil Agencies)

### 2.3 Military Standards:<sup>4</sup>

**MIL-STD-129** Marking for Shipment and Storage

### 2.4 NSF Standards:<sup>5</sup>

**Standard No. 14** for Plastic Piping Components and Related Materials

**Standard No. 61** for Drinking Water Systems Components—Health Effects

## 3. Terminology

### 3.1 Definitions:

3.1.1 *General*—Definitions used in this specification are in accordance with Terminology **F412** and abbreviations are in accordance with Terminology **D1600**, unless otherwise specified. The abbreviation for Aluminum is AL.

### 3.2 Definitions of Terms Specific to This Standard: **ASTM F2855-19**

3.2.1 *CPVC-AL-CPVC composite tubing, n*—composite tubing produced by coextrusion or extrusion of layers of CPVC/Aluminum/CPVC bonded together with a melt adhesive. This construction is also known as “multilayer”.

3.2.2 *tubing, n*—For the purpose of this specification, pipe made the specific dimensions shown in **Table 1**.

3.2.3 *nominal tubing size (NTS), n*—A non-dimensional tubing sizing convention based on copper tubing sizing, **CTS**, dimensions in which the nominal measured OD is the NTS size plus 0.125 in. For example, NTS **CTS**, ½ tubing has a nominal OD of 0.625 in.

**TABLE 1 Outside Diameters, Wall Thicknesses, and Tolerances for CPVC-AL-CPVC Composite Pipe**

NTS	Outside Diameter, in. (mm)		Inside Diameter, in. (mm)		Wall Thickness, in. (mm)			
	Average	Tolerance on Average	Average	Tolerance on Average	Aluminum		Inner CPVC Layer	Outer CPVC Layer
					Average	Tolerance on Average	Minimum	Minimum
½	0.625 (15.88)	±0.003 (0.08)	0.448 (11.38)	±0.003 (0.08)	0.017 (0.43)	±0.002 (0.05)	0.025 (0.64)	0.025 (0.64)
¾	0.875 (22.23)	±0.003 (0.08)	0.691 (17.55)	±0.004 (0.10)	0.017 (0.43)	±0.002 (0.05)	0.028 (0.71)	0.028 (0.71)
1	1.125 (28.58)	±0.003 (0.08)	0.932 (23.67)	±0.005 (0.13)	0.017 (0.43)	±0.002 (0.05)	0.034 (0.86)	0.034 (0.86)

<sup>2</sup> For referenced ASTM standards, visit the ASTM website, www.astm.org, or contact ASTM Customer Service at service@astm.org. For *Annual Book of ASTM Standards* volume information, refer to the standard’s Document Summary page on the ASTM website.

<sup>3</sup> The last approved version of this historical standard is referenced on www.astm.org.

<sup>4</sup> Available from Standardization Documents Order Desk, DODSSP, Bldg. 4, Section D, DLA Document Services, Building 4/D, 700 Robbins Ave., Philadelphia, PA 19111-5098, <http://dodssp.daps.dla.mil>, 19111-5094, <http://quicksearch.dla.mil>.

<sup>5</sup> Available from NSF International, P.O. Box 130140, 789 N. Dixboro Rd., Ann Arbor, MI 48113-0140, <http://www.nsf.org>.

#### 4. Classification

4.1 *Tubing*—This specification classifies CPVC-AL-CPVC composite tubing and CPVC bushings by a maximum continuous operating condition of 100 psi (690 kPa) at 180°F (82°C) and by nominal tubing sizes of ½ NTS, ¾ NTS and 1 NTS.

4.2 *Pressure Design Basis* The CPVC-AL-CPVC composite tubing shall have an established pressure design basis at 73°F (23°C) of 800 psi (5.52 MPa) or greater and at 180°F (82°C) of 200 psi (1.38 MPa) or greater in accordance with Test Method [D2837](#).

#### 5. Materials

5.1 *General*—The CPVC-AL-CPVC composite tubing is composed of an internal CPVC layer, adhesive layer, aluminum layer, adhesive layer and external CPVC layer. For tubing made to this specification, the constituent materials must meet the following requirements:

5.2 *Aluminum*—The thickness of the aluminum layer shall meet the dimensions and tolerance given in [Table 1](#). The tensile properties of the aluminum material shall be a minimum tensile strength of 14,600 psi (100 MPa) and an elongation of 20% when tested in accordance with Test Method [E8/E8M](#).

5.3 *Melt Adhesive*—The melt adhesive that bonds the CPVC layers to the Aluminum layer shall be of sufficient strength that no debonding of the layers occurs when the CPVC-AL-CPVC composite tubing is tested to all the requirements in Section 6 of this standard and to the requirements for Hydrostatic Burst Strength and CPVC Adhesives as specified in Specification [D2846/D2846M](#).

5.4 *CPVC*—The CPVC compound used to make the inner and outer layers shall meet the requirements specified in [5.4.1](#) and [5.4.2](#).

5.4.1 *Short-Term Properties*—The CPVC compound shall meet the requirements of cell classification CPVC 23447 as specified in Specification [D1784](#).

5.4.2 *Long-Term Hydrostatic Strength*—The CPVC compound shall have an established 180°F (82°C) hydrostatic design stress of 500 psi (3.45 MPa) or greater in accordance with Test Method [D2837](#).

5.5 *Rework Material*—Rework material generated from CPVC-AL-CPVC composite tubing shall not be used.

#### 6. Requirements

6.1 *General*—The requirements and test methods in this specification cover CPVC-AL-CPVC composite tubing. Tests on the individual layers that comprise this composite tubing are outside the scope of this specification. The raw materials used, however, must conform to the requirements as set out in Section 5.

6.2 *Dimensions and Tolerance of Tubing:*

6.2.1 *Tubing Diameter*—The minimum outside diameter and tolerances of the tubing shall meet the requirements given in [Table 1](#), when measured in accordance Test Method [D2122](#). Maximum and minimum (out-of-roundness) tolerances apply only to measurements made on tubing prior to coiling.

6.2.2 *Tubing Wall Thickness:*

6.2.2.1 *Overall Tubing Wall Thickness*—The overall tube wall thickness shall meet the requirements given in [Table 1](#), when measured in accordance with Test Method [D2122](#). The minimum wall thickness at any point of measurement of the tube shall not be less than the value specified in [Table 1](#).

6.2.2.2 *CPVC Layer Wall Thickness*—The minimum wall thickness at any point of measurement of the tube shall not be less than the value specified in [Table 1](#).

NOTE 3—An optical comparator has been found to be an excellent method for measuring the wall thickness of the various layers in piping. A ring is cut from the tubing and placed on the optical comparator for measurement determination.

6.2.3 *Tubing Length*—The tubing shall be supplied coiled or in straight lengths as agreed upon with the purchaser and with an allowable tolerance of +1 / -0 ft (+305 / -0 mm) for coils and +1/2 / -0 in. (+13 / -0 mm) for straight lengths.

6.3 *Delamination*—CPVC-AL-CPVC tubing shall not show any separation of the CPVC layer from either side of the aluminum layer when tested in accordance with [9.2](#).

6.4 *Apparent Tensile Strength of Tubing*—The tube rings, when tested in accordance with the Ring Test Method of Test Method [F1281](#), shall meet the minimum strength as specified in [Table 2](#).

**TABLE 2 Minimum Tube Strength – N (lb)**

½ NTS	2300 (515)
¾ NTS	2500 (560)
1 NTS	2500 (560)

6.5 *Hydrostatic Sustained Pressure*—CPVC-AL-CPVC tubing shall meet the minimum hydrostatic sustained pressure requirements of both ~~test conditions~~ Test Conditions A and B, in either air or water shown in **Table 3** when tested in accordance with the Hydrostatic Sustained Pressure Method of Specification **D2846/D2846M**.

6.6 Requirements for the, installation required, CPVC bushings are in mandatory **Annex A1**.

**7. Requirements for Joints made with Solvent Cement**

7.1 CPVC-AL-CPVC joints made with solvent cement shall meet the Requirements for Solvent Cement and Adhesive Joints of Specification **D2846/D2846M** when assembled in accordance with **Annex A2** as specified for:

7.1.1 Hydrostatic Burst Strength

7.1.1.1 The specimen size for the Hydrostatic Burst Strength shall be 1 NTS.

7.1.2 Hydrostatic Sustained Pressure Strength

7.1.3 Thermocycling

7.2 Special requirements for joining CPVC-AL-CPVC tubing are contained in mandatory **Annex A1** and **Annex A2**.

NOTE 4—In order to assure the expected life expectancy of CPVC-AL-CPVC composite tubing by preventing corrosion of the Aluminum, a bushing meeting the requirements of **Annex A1** is required to be solvent cemented into the cut ends of the CPVC-AL-CPVC tubing prior to making solvent cement joints in the piping. This bushing seals off the cut ends of the tubing preventing any contact of the AL layer with any liquids being transported by the tubing.

**8. Workmanship, Finish, and Appearance**

8.1 *Workmanship*—The composite tubing and associated bushings shall be homogeneous throughout and free of visible cracks, holes, foreign inclusions, or other defects. The tubing and associated bushings shall be as uniform as commercially practicable in color, opacity, density, and other physical properties.

**9. Test Methods for Tubing**

9.1 *Sampling*—A sufficient quantity of composite tubing, as agreed upon between the purchaser and the seller, shall be selected from each lot or shipment and tested to determine conformance with this specification (see Practice **D1898**). In the case of no prior agreement, random samples selected by the testing laboratory shall be deemed adequate.

9.1.1 *Test Specimens*—Not less than 50 % of the test specimens required for any pressure test shall have at least a part of the marking in their central sections. The central section is that portion of tubing which is at least one tubing diameter away from an end closure.

9.2 *Delamination Test*—Cut two ½ to 1 in. rings from the tubing to be tested. Using a band saw, slice each ring lengthwise into two approximately equal semicircular, arc-shaped specimens. The Slice on the second ring shall be at 90° from the slice on the first ring so that each of the four specimens represents one quadrant of the circumference of the pipe. One specimen must have the print line at the center of the arc. With pliers grasp the opposing ends of arc and bend back the edges so that the outside edges of the arcs meet. When the bent specimen is visually inspected, failure is defined as any separation of the CPVC layer from either side of the aluminum layer.

**10. Retest and Rejection**

10.1 If the results of any test(s) do not meet the requirements of this specification, the tests(s) shall be conducted again only by agreement between the purchaser and seller. Under such agreement, minimum requirements shall not be lowered, changed, or modified, nor shall specification limits be changed. If upon retest, failure occurs, the quantity of product represented by the test(s) does not meet the requirements of this specification.

**11. Product Marking**

11.1 *Quality of Marking*—The marking shall be applied to the tubing in such a manner that it remains legible (easily read) after installation and inspection.

11.2 Markings on the tubing shall include the following, spaced at intervals of not more than 1.5 m (5 ft):

11.2.1 Nominal size,

**TABLE 3 Minimum Hydrostatic Sustained Pressure Requirements for CPVC-AL-CPVC Tubing Assemblies Tested in Either Water or Air Bath External Environment at 180°F (82°C)**

Test Condition	Test Duration	Hydrostatic Test Pressure	
		Water Bath	Air Bath
A	6 min	521 psi (3 590 kPa)	551 psi (3 800 kPa)
B	4 h	364 psi (2 510 kPa)	403 psi (2 780 kPa)

11.2.2 Manufacturer's name (or trademark), and production code,

11.2.3 Immediately following the manufacturer's name (or trademark), the tube type "CPVC-AL-CPVC Tubing",

11.2.4 The marking, "0.079 in. minimum wall",

11.2.5 The marking, in capital letters: "CAUTION: USER SHALL FIRST SOLVENT CEMENT F2855 BUSHINGS INTO CUT ENDS OF TUBING PRIOR TO JOINING" (See [Appendix X3 Annex A2](#) for bushing installation instructions.)

11.2.6 Pressure rating at 180°F (82°C) (see [Appendix X1](#)).

11.2.7 ASTM designation F2855, with which the tubing complies,

11.2.8 Components intended for the transport of potable water shall also include the seal or mark of the laboratory making the evaluation for this purpose, spaced at intervals specified by the laboratory (See Supplementary Requirement

NOTE 5—Manufacturers using the seal or mark of a laboratory must obtain prior authorization from the laboratory concerned.

## 12. Quality Assurance

12.1 When the product is marked with this designation, F2855, the manufacturer affirms that the product was manufactured, inspected, sampled, and tested in accordance with this specification and has been found to meet the requirements of this specification.

## 13. Keywords

13.1 cold-water pipe; CPVC-AL-CPVC; hot-water pipe; tubing; water distribution tubing

### SUPPLEMENTARY REQUIREMENTS

#### GOVERNMENT/MILITARY PROCUREMENT

These requirements apply only to Federal/Military procurement, not domestic sales of transfers.

S1. *Responsibility for Inspection*—Unless otherwise specified in the contract or purchase order, the producer is responsible for the performance of all inspection and test requirements specified herein. The producer may use his own or any other suitable facilities for the performance of the inspection and test requirements specified herein, unless the purchaser disapproves. The purchaser shall have the right to perform any of the inspections and tests set forth in this specification where such inspections are deemed necessary to ensure that material conforms to prescribed requirements.

NOTE S1—In U.S. Federal contracts, the contractor is responsible for inspection.

#### S2. *Packaging and Marking for U.S. Government Procurement:*

S2.1 *Packaging* —Unless otherwise specified in the contract, the materials shall be packaged in accordance with the supplier's standard practice in a manner ensuring arrival at destination in satisfactory condition and which will be acceptable to the carrier at lowest rates. Containers and packing shall comply with Uniform Freight Classification rules or National Motor Freight Classification rules.

*Marking* —Marking for shipment shall be in accordance with Fed. Std. No. 123 for civil agencies and MIL-STD-129 for military agencies.

NOTE S2—The inclusion of U.S. Government procurement requirements should not be construed as an indication that the U.S. Government uses or endorses the products described in this document.

### POTABLE WATER REQUIREMENT

This requirement applies whenever a Regulatory Authority or user calls for product to be used to convey or be in contact with potable water.

S3. Products intended for contact with potable water shall be evaluated, tested and certified for conformance with NSF/ANSI Standard No. 61 or the health effects portion of NSF Standard No. 14 by an acceptable certifying organization when required by the regulatory authority having jurisdiction.

**ANNEXANNEXES**

**(Mandatory Information)**

**A1. INTERNAL BUSHINGS FOR USE WITH CPVC-AL-CPVC COMPOSITE TUBING**

A1.1 *Bushing Requirement*—When installing CPVC-AL-CPVC composite tubing covered by this specification, bushings described in this Annex shall be solvent cemented into the cut ends of the CPVC-AL-CPVC composite tubing prior to making solvent cement joints. (See [Appendix X3 Annex A2](#) for assembly instructions.)

NOTE A1.1—Failure to install these bushings into the ends of the CPVC-AL-CPVC composite tubing could result in a shortening of the expected life of the piping system due to corrosion of the Aluminum.

A1.2 The CPVC material used to make the bushings for use with the CPVC-AL-CPVC tubing shall meet the requirements of 5.4.1.

A1.3 Internal bushings for use with CPVC-AL-CPVC tubing shall meet the dimensional requirements of [Table A1.1](#).

A1.4 *Marking*—The following marking is required on bushings, except where size makes such marking impractical. Where markings are omitted, fittings shall be identified by some symbol which is defined in the manufacturer’s trade literature. Marking on fittings shall be molded, hot stamped, or applied in some other permanent manner so as to remain legible under normal handling and installation practice. Where recessed marking is used, care shall be taken to see that wall thicknesses are not reduced below the specified minimums.

A1.4.1 Manufacturer’s name (or trademark), and production code,

**TABLE A1.1 Dimensions of Internal Bushings**

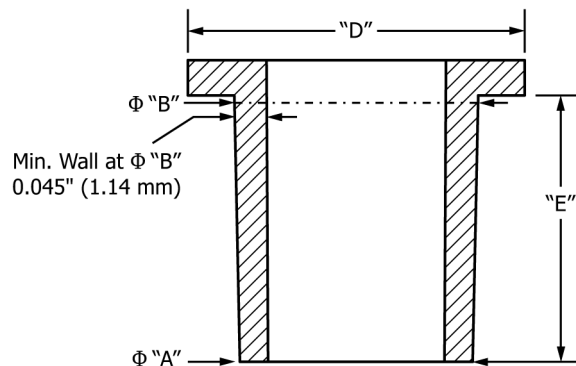

Nominal Tube Size	Φ"A" in. (mm)	Φ"B" in. (mm)	Φ"D" in. (mm)	"E" in. (mm) Minimum
½ NTS	0.434 ± .004 (11.02 ± 0.10)	0.448 ± .004 (11.38 ± 0.10)	0.615 ± .003 (15.62 ± 0.13)	0.500 (12.70)
¾ NTS	0.675 ± .004 (17.15 ± 0.10)	0.689 ± .004 (17.50 ± 0.10)	0.860 ± .003 (21.84 ± 0.13)	0.700 (17.78)
1 NTS	0.917 ± .004 (23.29 ± 0.10)	0.930 ± .004 (23.62 ± 0.10)	1.116 ± .003 (28.35 ± 0.13)	0.900 (22.86)