



Designation: ~~D3012~~—~~13~~ **D3012** – 19

## Standard Test Method for Thermal-Oxidative Stability of Polypropylene Using a Specimen Rotator Within an Oven<sup>1</sup>

This standard is issued under the fixed designation D3012; the number immediately following the designation indicates the year of original adoption or, in the case of revision, the year of last revision. A number in parentheses indicates the year of last reapproval. A superscript epsilon ( $\epsilon$ ) indicates an editorial change since the last revision or reapproval.

### 1. Scope\*

1.1 This test method provides a means for estimating the resistance of polypropylene, in molded form, to accelerated aging by heat in the presence of air using a forced draft oven.

1.2 The stability determined by this test method is not directly related to the suitability of the material for use when different environmental conditions prevail and shall not be used to predict performance.

NOTE 1—The specified thermal levels in this test method are considered sufficiently severe to cause failure of commercial grades of heat-stable polypropylene within a reasonable period of time. If desired, lower temperatures can be applied to estimate the performance of polypropylene with lower heat stabilities.

1.3 The values stated in SI units are to be regarded as the standard. The values in parentheses are for information only.

1.4 *This standard does not purport to address all of the safety concerns, if any, associated with its use. It is the responsibility of the user of this standard to establish appropriate safety, health, and environmental practices and determine the applicability of regulatory limitations prior to use.*

NOTE 2—This test method and ISO 4577–1983 are technically similar but different in preparation of test specimens, thickness of test specimen, measurement of the number of air flow changes in the ovens, and the number of air changes per hour required.

1.5 *This international standard was developed in accordance with internationally recognized principles on standardization established in the Decision on Principles for the Development of International Standards, Guides and Recommendations issued by the World Trade Organization Technical Barriers to Trade (TBT) Committee.*

### 2. Referenced Documents

#### 2.1 ASTM Standards:<sup>2</sup>

[D618 Practice for Conditioning Plastics for Testing](#) [ASTM D3012-19](#)

[D883 Terminology Relating to Plastics](#)

[D3641 Practice for Injection Molding Test Specimens of Thermoplastic Molding and Extrusion Materials](#)

[D4101 Classification System and Basis for Specification for Polypropylene Injection and Extrusion Materials](#)

[D5374 Test Methods for Forced-Convection Laboratory Ovens for Evaluation of Electrical Insulation](#)

[E77 Test Method for Inspection and Verification of Thermometers](#)

[E220 Test Method for Calibration of Thermocouples By Comparison Techniques](#)

[E456 Terminology Relating to Quality and Statistics](#)

[E608/E608M Specification for Mineral-Insulated, Metal-Sheathed Base Metal Thermocouples](#)

[E644 Test Methods for Testing Industrial Resistance Thermometers](#)

[E691 Practice for Conducting an Interlaboratory Study to Determine the Precision of a Test Method](#)

[E1137/E1137M Specification for Industrial Platinum Resistance Thermometers](#)

[E2251 Specification for Liquid-in-Glass ASTM Thermometers with Low-Hazard Precision Liquids](#)

[E2935 Practice for Conducting Equivalence Testing in Laboratory Applications](#)

#### 2.2 ISO Standard:<sup>3</sup>

[ISO 4577–1983 Plastics—Polypropylene and Propylene Copolymers—Determination of Thermal Oxidative Stability in Air-Oven Method](#)

<sup>1</sup> This test method is under the jurisdiction of ASTM Committee D20 on Plastics and is the direct responsibility of Subcommittee D20.15 on Thermoplastic Materials. Current edition approved April 1, 2013; April 1, 2019. Published April 2013; May 2019. Originally approved in 1972. Last previous edition approved in 2007/2013 as ~~D3012-07~~-D3012 - 13. DOI: [10.1520/D3012-13.10.1520/D3012-19](#).

<sup>2</sup> For referenced ASTM standards, visit the ASTM website, [www.astm.org](#), or contact ASTM Customer Service at [service@astm.org](#). For *Annual Book of ASTM Standards* volume information, refer to the standard's Document Summary page on the ASTM website.

<sup>3</sup> Available from American National Standards Institute (ANSI), 25 W. 43rd St., 4th Floor, New York, NY ~~10036~~-10036, [http://www.ansi.org](#).

\*A Summary of Changes section appears at the end of this standard

**ISO 18731:2006** Plastics—Polypropylene and Propylene-Copolymer Thermoplastics:(PP) Moulding and Extrusion Materials:  
**Part 1: Designation System and Basis for Specifications**  
**Part 2: Preparation of Test Specimens and Determination of Properties**

### 3. Terminology

3.1 *Definitions*—~~The definitions of plastics Terms used in this test method standard are defined in accordance with Terminology D883 unless otherwise indicated.~~, unless otherwise specified. For terms relating to precision and bias and associated issues, the terms used in this standard are defined in accordance with Terminology [E456](#).

3.1.1 *repeatability*—precision under repeatability conditions. ([E456](#))

3.1.2 *repeatability conditions, n*—conditions where independent test results are obtained with the same method on identical test items in the same laboratory by the same operator using the same equipment within short intervals of time. ([E456](#))

3.1.3 *reproducibility*—precision under reproducibility conditions. ([E456](#))

3.1.4 *reproducibility conditions, n*—conditions where test results are obtained with the same method on identical test items in different laboratories with different operators using different equipment. ([E456](#))

### 4. Summary of Test Method

4.1 Aging is accelerated by exposing the specimens to an elevated temperature in a forced draft oven equipped with a biaxial or uniaxial rotating specimen holder.

4.2 Visual examination is used to determine the time to failure. The time to failure of the material is taken as the number of days after which the specimen shows ~~localized crazing~~, the initial start of any visual type of localized crazing, cracking, holes, crumbling, or discoloration, or a combination thereof.

### 5. Significance and Use

5.1 Under the severe conditions of this test method, the specimens undergo degradation at a rate that is dependent upon the thermal endurance of the polypropylene material under examination.

5.2 The thermal level of this test method is considered sufficiently severe to cause failure of commercial grades of heat-stable polypropylene within a reasonable period of time. If desired, lower temperatures can be applied to estimate the performance of polypropylene materials with lower heat stability.

5.3 The technique of specimen rotation described in this test method provides an estimate of the life-temperature relationship of polypropylene. If this test method is conducted at different temperatures on the same material, a more reliable estimate of the life-temperature relationship of polypropylene is determined. This test method can be conducted at several temperatures and the data interpreted through use of the Arrhenius relation, by plotting the logarithms of times to failure against the reciprocals of the temperatures in kelvins (K). Temperatures in the range from 100 to 150°C, with intervals of 10°C, are suggested for this purpose.

5.4 The stability as determined under the prescribed test method is not directly related to the suitability of the compound for a use where different conditions prevail.

5.5 The specimen rotation technique of thermal aging increases the probability that all specimens will be exposed similarly and that the effect of temperature gradients in an oven will be minimized.

### 6. Apparatus

6.1 *Oven*, mechanical convection type for controlled circulation of ~~air~~, air (for example, a forced draft type), with adjustable air intake and exhaust facilities, and designed for air velocities around  $1000 \pm 250$  mm/s ( $197 \pm 49$  ft/min).<sup>4</sup>

6.1.1 The oven shall be equipped with a temperature-control system designed to maintain the test temperature range from  $150 \pm 1^\circ\text{C}$  ( $302 \pm 1.8^\circ\text{F}$ ) and a device to prevent temperature override. With the oven adjusted to the nominal test temperature of  $150^\circ\text{C}$ , the override shall be set at  $154^\circ\text{C}$  ( $309^\circ\text{F}$ ). A bimetallic-strip temperature switch has been found satisfactory.

6.2 *Oven Temperature Measurement System*, consisting of a thermocouple, thermometer, or resistance thermometer as the sensor, together with its associated conditions and readout instrumentation covering at least the temperature range from 0 to  $200^\circ\text{C}$  ( $32$  to  $372^\circ\text{F}$ ).

6.2.1 The thermometer must cover the range in one-degree subdivisions. It must be tested for bulb stability and standardized, in accordance with Test Method [E77](#).

6.2.2 The secondary standard shall be ASTM Thermometer S67C-03 of Specification [E2251](#).

6.2.3 Thermocouples shall comply with the requirements of Specification [E608/E608M](#) and shall be calibrated in accordance with Method [E220](#).

<sup>4</sup> A Precision Scientific Freas Model 835 B, or Blue M POM-206C-1, or equivalent, can be used. ~~are known as acceptable ovens for this test, but other equivalent models meeting the requirements in 6.1, 6.1.1, and Section 9 are allowed.~~

6.2.4 Resistance thermometers shall comply with the requirements of Test Methods E644 and Specification E1137/E1137M, and be calibrated in accordance with NIST Special Publication 250-22.<sup>5,6</sup>

6.3 *Molding Press*, designed to operate at  $200 \pm 5^\circ\text{C}$  ( $392 \pm 9^\circ\text{F}$ ).

6.4 *Injection Molding Unit*, meeting the requirements of Practice D3641.

6.5 *Mold*:

6.5.1 *Compression Mold*, comprised of the following:

6.5.1.1 *Compression Molding Chase*, having a blanked-out area of suitable size (Note 3) and capable of producing a plaque  $1.00 \pm 0.05$  mm ( $0.039 \pm 0.002$  in.) thick.

NOTE 3—A 152.4 by 152.4-mm (6 by 6-in.) blanked-out section has been found satisfactory.

6.5.1.2 *Backing Plates*, large enough to cover this chase and strong enough to resist warping or distortion, under the molding conditions. Polished steel plates, 3 mm (0.1 in.) thick, are satisfactory.

6.5.2 *Injection Mold*, designed using the guidelines specified in Practice D3641. The mold shall be capable of producing either a plaque having a thickness of  $1.00 \pm 0.05$  mm ( $0.039 \pm 0.002$  in.) from which 50 by 10 by 1.00-mm (2 by 0.4 by 0.039-in.) specimens can be die cut, or mold a standard test specimen, 50 by 10 by 1.00 mm.

6.6 *Parting Sheets*—Fluoropolymer, polyester, or other film that will not affect the long-term thermal stability of polypropylene, 0.05 to 0.20 mm (0.002 to 0.008 in.) thick. The film must be free of wrinkles and foreign matter, such as lubricants and oils.

6.7 *Cutting Die*, to produce 50 by 10-mm (2 by 0.4-in.) specimens from either a compression-molded or injection-molded plaque. The die must be sharp and free of nicks.

6.8 *Specimen Holder*—The specimen holder ~~can be biaxially rotated~~ is either a biaxially or uniaxially rotated ~~provided that unit,~~ capable of exposing the test specimens ~~are in~~ to a stream of air having a relative velocity about 1000 mm/s (197 ~~ft/min~~–ft/min) (see 9.3). Illustrations of suitable apparatus for biaxially and uniaxially rotated specimen holders are shown in Figs. 1 and 2, respectively. Biaxial rotation increases the probability that all specimens will be exposed similarly. In the case of dispute, the use of biaxial rotation shall be the reference method.

6.8.1 *Biaxially Rotated Specimen Holder* (see Fig. 1)<sup>7</sup>. The frequency of rotation about the horizontal and vertical axes shall be 1 to 3 min<sup>-1</sup>.

6.8.2 *Uniaxially Rotated Specimen Holder* (see Fig. 2). The drum peripheral velocity shall be such that the air stream impinges on the flat section of the test specimens at about 1 m/s.

6.9 *Air Velocity Meter*, nondirectional resistance wire type for measuring the air velocity in the oven.

ASTM D3012-19

<https://standards.iteh.ai/catalog/standards/sist/14b245c3-643f-495d-ab46-5d44bd3e09a7/astm-d3012-19>

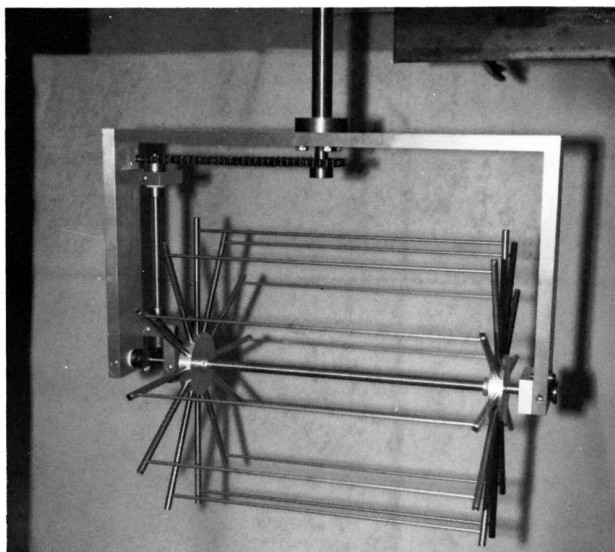

FIG. 1 Biaxial Ferris-Wheel-Type Rotator

<sup>5</sup> Mangum, B. W., "Platinum Resistance Thermometer Calibration," NBS Special Publication 250-22 (1987).

<sup>6</sup> Available from National Institute of Standards and Technology (NIST), 100 Bureau Dr., Stop 3460, Gaithersburg, MD 20899-3460.

<sup>7</sup> Standard Scientific Supply Company, Model CS191, or equivalent, can be used.

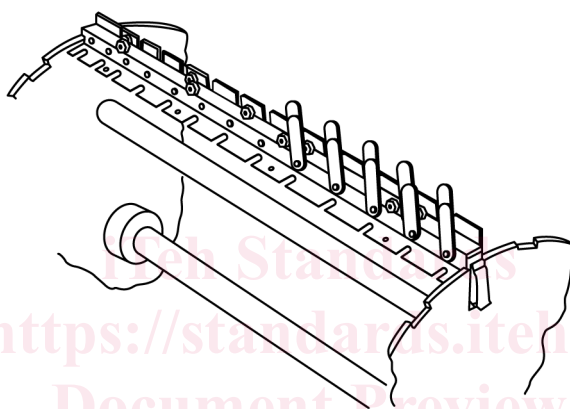
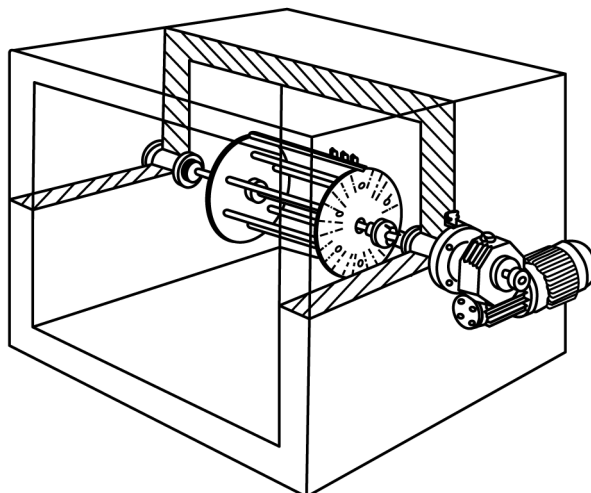

FIG. 2 Uniaxially Rotated Specimen Holder—Drum Rotator

6.10 *Anemometer*, with a circular vane, for determining the frequency of air changes in the oven. The anemometer shall be positioned directly in front of the oven outlet. Based on the design of the outlet and the anemometer, every effort shall be made to position the anemometer's electronics in a way as to minimize the degree of exposure to the heated air exiting the oven.

6.11 *Metal Clips*, lined with fluorocarbon film or other materials that have no adverse effect on the oxidative thermal stability of polypropylene.

## 7. Specimen Preparation

7.1 The test specimens shall be cut from either a compression-molded plaque or injection-molded plaque prepared from granules, powders, granules, pellets, etc., or other homogeneous molding material. Plaques shall be prepared as follows:

### 7.2 *Compression Molding:*

7.2.1 Adjust the temperature of the platens to  $200 \pm 5^\circ\text{C}$  ( $392 \pm 9^\circ\text{F}$ ).

7.2.2 Place a smooth, clean parting sheet on a backing plate and center the chase on it. Put enough of the sample into the cavity to fill it completely when molded. A slight excess of material is desirable. Cover the loaded chase first with a clean parting sheet and then a backing plate. Finally, put the assembled mold on the lower platen and close the press carefully until both platens are in contact with the assembly. When the material has melted, apply sufficient pressure to form a void-free plaque in the  $1.00 \pm 0.5$  mm ( $0.039 \pm 0.002$  in.) thick and record this pressure. Leave the polypropylene in the heated press under pressure for 3 to 4 min at  $200 \pm 5^\circ\text{C}$  ( $392 \pm 9^\circ\text{F}$ ). Flash cool the mold assembly by transferring to a water-cooled press or by water quenching.

NOTE 4—For some polypropylene materials that do not provide a fully filled-out and uniform compression molded plaque at the at the conditions in 7.2.2, alternative and adjustments to the temperature, pressure and/or molding times would need to be made to provide an acceptable molded specimen. This changes shall be noted in the report 11.1.4.

### 7.3 *Injection Molding:*

7.3.1 Plaques or test specimens shall be injection-molded in accordance with the requirements of Specification **D4101**.

7.4 Prepare a minimum of five specimens per material sample by die-cutting specimens from the plaque or directly molding the standard test specimen. The standard specimen shall be 10 mm wide, 50 mm long, and  $1.00 \pm 0.05$  mm thick. Edges shall be smoothed, if necessary, to remove imperfections introduced by cutting.