



Designation: **E3110–18 E3110/E3110M – 19**

Standard Test Method for Collection of Ballistic Limit Data for Ballistic-resistant Torso Body Armor and Shoot Packs¹

This standard is issued under the fixed designation ~~E3110~~; E3110/E3110M; the number immediately following the designation indicates the year of original adoption or, in the case of revision, the year of last revision. A number in parentheses indicates the year of last reapproval. A superscript epsilon (ϵ) indicates an editorial change since the last revision or reapproval.

1. Scope

- 1.1 This test method addresses the collection of ballistic limit data for ballistic-resistant torso body armor and shoot packs.
- 1.2 This test method is intended for testing of soft body armor, hard armor plates, and shoot packs. This test method does not apply to ballistic helmets.
- 1.3 This test method describes procedures for collecting data and does not specify computation or performance criteria for the ballistic limit. Instructions for computation and performance criteria are specified in other standards and specifications.
- 1.4 Several commonly used test item mounting procedures and ballistic limit procedures are included in this test method; certifiers, purchasers, and other users will specify the procedures to be used.
- 1.5 This test method does not address conditioning of test items.
- 1.6 It is anticipated that this test method will be referenced by certifiers, purchasers, or other users to meet their specific needs.
 - 1.6.1 Certifier, purchasers, and other users will specify and describe the ballistic test threats to be used. Within this test method, the reference will be called the “test threats document.”
 - 1.6.2 Certifiers, purchasers, and other users will provide specific instructions for the determination of complete penetrations or partial penetrations.
 - 1.6.3 In this test method, “other standards and specifications” and “unless specified elsewhere” refer to documents (for example, military standards, purchase specifications) that require the use of this test method. Certifiers, purchasers, and other users are responsible for the “other standards and specifications” and for specifying any requirements that supersede those of this test method.
- 1.7 Units—The values stated in either SI units or inch-pound units are to be regarded separately as standard. The values given stated in parentheses are ~~mathematical conversions to inch-pound units that are provided for information only and are not considered standard~~ each system are not necessarily exact equivalents; therefore, to ensure conformance with the standard, each system shall be used independently of the other, and values from the two systems shall not be combined.
 - 1.7.1 The user of this standard will identify the system of units to be used, and it is critical to ensure that any cross-referenced standards maintain consistency of units between standards.
- 1.8 *This standard does not purport to address all of the safety concerns, if any, associated with its use. It is the responsibility of the user of this standard to establish appropriate safety, health, and environmental practices and determine the applicability of regulatory limitations prior to use.*
- 1.9 *This international standard was developed in accordance with internationally recognized principles on standardization established in the Decision on Principles for the Development of International Standards, Guides and Recommendations issued by the World Trade Organization Technical Barriers to Trade (TBT) Committee.*

2. Referenced Documents

- 2.1 *ASTM Standards:*²
~~B209/B209M~~ B209 Specification for Aluminum and Aluminum-Alloy Sheet and Plate

¹ This test method is under the jurisdiction of ASTM Committee E54 on Homeland Security Applications and is the direct responsibility of Subcommittee E54.04 on Personal Protective Equipment (PPE).

Current edition approved ~~March 1, 2018~~ May 1, 2019. Published ~~March 2018~~ May 2019. Originally approved in 2018. Last previous edition approved in 2018 as E3110 – 18. DOI: ~~10.1520/E3110-18~~ 10.1520/E3110_E3110M-19.

² For referenced ASTM standards, visit the ASTM website, www.astm.org, or contact ASTM Customer Service at service@astm.org. For *Annual Book of ASTM Standards* volume information, refer to the standard’s Document Summary page on the ASTM website.

[E3004 Specification for Preparation and Verification of Clay Blocks Used in Ballistic-Resistance Testing of Torso Body Armor](#)

[E3005 Terminology for Body Armor](#)

[E3062/E3062M Specification for Indoor Ballistic Test Ranges for Small Arms and Fragmentation Testing of Ballistic-resistant Items](#)

[E3086 Practice for Creating Appliques for Use in Testing of Nonplanar Soft Body Armor Designed for Females](#)

2.2 *U.S. Army Research Laboratory:*

[ARL-TN-437 LangMod Users Manual](#)³

2.3 *Department of Defense Standards:*⁴

[MIL-STD-662F V₅₀ Ballistic Test for Armor](#)

2.4 *Department of Justice Standards:*

[NIJ Standard–0101.06 Ballistic Resistance of Personal Body Armor](#)⁵

2.5 *ISO Standards:*⁶

[ISO/IEC 17025 General Requirements for the Competence of Testing and Calibration Laboratories](#)

3. Terminology

3.1 For terms not defined in this test method, the following definitions of Terminology [E3005](#) apply: *angle of incidence, backing assembly, backing material, backing fixture, body armor, complete penetration, fair hit, hard armor, obliquity, partial penetration, plates, shoot pack, shot-to-edge distance, shot-to-shot distance, soft body armor, stop, strike face, test item, unfair hit, V_x, V₅₀, and yaw.*

3.2 *Definitions of Terms Specific to This Standard:*

3.2.1 *angle of incidence, n*—the angle between the test threat line of aim and the line normal to a reference plane based on the front surface of the backing assembly or witness panel. **adapted from Terminology [E3005](#)**

3.2.2 *applique*—a three-dimensional item molded from backing material that is shaped and sized for testing or conditioning a nonplanar test item.

3.2.2.1 *Discussion*—

Some appliques are designed for the purpose of filling the entire space behind a nonplanar test item; other appliques are designed to assess features of a nonplanar test item (Practice [E3086](#)).

3.2.3 *ballistic limit, n*—a measure of an item's ballistic resistance to complete penetration expressed as a velocity associated with some probability of perforation.

3.2.3.1 *Discussion*—

<https://standards.iteh.ai/catalog/standards/sist/a597cede-2ca8-487c-b7c4-cfa934d5c7bc/astm-e3110-e3110m-19>

The item may be a test item, material, shoot pack, body armor, or other ballistic-resistant product.

3.2.4 *gate, n*—the lower and upper test threat velocity limits.

3.2.5 *test series, n*—the set of all shots necessary to obtain the required number of fair hits on a single test item or the set of all shots necessary over multiple test items to generate the required data.

3.2.6 *warmer round, n*—a projectile fired from a receiver or firearm, prior to testing, to warm the test barrel.

3.2.7 *zone of mixed results (ZMR), n*—during V₅₀ ballistic testing, the range of velocities between the highest partial penetration and lowest complete penetration when the partial penetration velocity is higher than the complete penetration velocity.

4. Summary of Test Method

4.1 This test method specifies multiple methods for ballistic limit testing, which are designed to estimate the penetration resistance of soft body armor, hard armor, or shoot packs.

4.2 The test method also specifies multiple methods for mounting test items. A test item is either mounted on a backing assembly with clay backing material or mounted in a frame with a separate witness panel.

4.3 Projectiles are fired at the test item starting at a specified velocity, with subsequent projectiles incrementally increasing or decreasing in velocity based on each shot outcome (complete penetration or partial penetration). This information is subsequently used to calculate the ballistic limit.

³ Available from U.S. Army Research Laboratory, 2800 Powder Mill Rd., Adelphi, MD 20783-1138, <https://www.arl.army.mil>.

⁴ Available from U.S. Government Printing Office, Superintendent of Documents, 732 N. Capitol St., NW, Washington, DC 20401-0001, <http://www.access.gpo.gov>.

⁵ Available from National Institute of Justice (NIJ), 810 7th St., NW, Washington, DC 20531, <http://nij.gov>.

⁶ Available from International Organization for Standardization (ISO), ISO Central Secretariat, BIBC II, Chemin de Blandonnet 8, CP 401, 1214 Vernier, Geneva, Switzerland, <http://www.iso.org>.

5. Significance and Use

5.1 U.S. Department of Defense and U.S. Department of Justice standards require ballistic limit determination for assessing the performance of ballistic-resistant body armor.

5.2 This test method may be used by private-sector and government laboratories, manufacturers, research and development organizations, and others assessing the ballistic resistance of body armor or performing research and development of new materials.

5.3 It is intended that this test method be referenced by other standards, specifications, and test methods.

6. Test Equipment and Apparatus

6.1 Test threats shall be specified in a separate test threats document.

6.2 The ballistic test range shall meet the requirements of Specification [E3062/E3062M](#).

6.2.1 The method for measuring yaw may be with a yaw card, flash radiography, high speed video, or photography.

6.3 When clay blocks are required to be used as backing assemblies behind test items, they shall meet the requirements of Specification [E3004](#).

6.4 For test procedures requiring the test item to be mounted in a frame, the frame shall consist of two layers of metal between which the test item is secured.

6.4.1 The frame shall be of sufficient size to allow restraint of the test item during ballistic impact. The frame, supports, clamps, and mounting fixtures shall be capable of securely retaining the test item and withstanding shock resulting from ballistic impact by the test projectiles.

6.4.2 Additional frame details, such as frame size and clamping force, are provided in other standards and specifications.

6.5 When required by some test procedures, a witness panel shall be used to determine whether a complete penetration has occurred.

6.5.1 The witness panel shall be at least 305 by 305 mm (~~12~~12 by 12 ~~in.~~in.).

NOTE 1—The witness panel may be larger to allow for impact by all fragments resulting from projectile penetration.

6.5.2 For opaque test items, the witness panel shall be a 0.50 ± 0.08 mm (~~0.020~~0.020 ± 0.003 ~~in.~~in.) thick sheet of 2024-T3, 2024-T4, or 5052 aluminum alloy.⁷

7. Hazards

7.1 The ballistic tests described in this test method have inherent hazards. Adequate safeguards for personnel and property shall be employed when conducting these tests.

8. Sampling and Test Items

8.1 The test items shall be individual soft armor panels, hard armor plates, or shoot packs.

8.2 Test item details, including quantity, size, and conditioning, shall be specified in other standards and specifications.

NOTE 2—It is recommended that spare test items be provided.

9. Test Requirements

9.1 Unless otherwise specified, each ballistic impact shall meet the requirements listed below to be considered a fair hit.

9.1.1 The test threat shall impact the test item at an angle $\leq 5^\circ$ from the intended angle.

9.1.2 The test threat shall have yaw verified to be $\leq 3^\circ$ for rifle threats or $\leq 5^\circ$ for fragment and handgun threats. Yaw shall be checked for every test threat shot.

9.1.2.1 The yaw measurement equipment shall be positioned perpendicular to the projectile line of flight. The yaw measurement equipment shall be securely mounted and anchored to maintain its required position and alignment.

9.1.2.2 When photographic means are used to assess the projectile yaw angle, the assessment shall be made as close as practical to the strike face of the test item but not more than 305 mm (~~12~~12 ~~in.~~in.) from the front of the strike face.

9.1.2.3 When yaw cards are used to assess the projectile yaw angle, unless specified elsewhere, the cards shall be positioned between 51 and 305 mm (~~2~~2 and 12 ~~in.~~in.) from the front of the strike face of the test item.

9.1.3 The test threat shall impact the test item no closer to the edge of the test item than the minimum shot-to-edge distance. The measurement for shot-to-edge distance shall be taken from the center of the projectile impact to the nearest edge of the ballistic material in the test item. Other standards and specifications shall specify the minimum shot-to-edge distance.

NOTE 3—Procedures for determining the edge of the test item should be specified in other standards or specifications.

⁷ Specifications for these alloys may be found in Specification [B209/B209M/B209](#) or equivalent international specifications.

9.1.4 For intended edge shots, the test threat shall impact the test item no further from the edge than the maximum shot-to-edge distance.

9.1.5 The test threat shall impact the test item no closer to a prior impact than the minimum shot-to-shot distance. The measurement for shot-to-shot distance shall be taken from the center of one projectile impact to the center of another. When the minimum shot-to-shot distance is not specified elsewhere, the minimum shot-to-shot distance shall be 51 mm (2 in.) [2 in.].

NOTE 4—For test items designed to defeat a single shot only, the minimum shot-to-shot distances discussed in this test method do not apply.

9.1.6 When assessing whether a particular impact location meets the minimum shot-to-shot distance requirements, the shot-to-shot distances should be measured from that impact location to all prior impact locations.

9.2 When warmer rounds are necessary, a test threat shall be fired through the projectile firing system to determine the exact point of impact. Additional test threats shall be fired as required until the proper alignment and a stable velocity have been achieved.

10. Mounting and Positioning of Soft Armor Test Items on a Clay Block

10.1 The test item shall be positioned on a clay block such that the entire test item is supported. When the test item exceeds the size of the clay block, backing fixture extensions shall be installed coplanar with the backing material surface to allow the test item to be fully supported.

10.1.1 Appliques needed for testing nonplanar soft armor test items shall be specified in other standards and specifications as necessary.

10.2 The test item shall be held in contact with the clay block (and appliques if present) and secured using approximately 51 to 76 mm (2 to 3 in.) wide elastic straps, held closed by hook-and-loop fasteners. Unless otherwise specified, two vertical and three horizontal straps shall be positioned such that they do not interfere with the impact points on the test item. Fig. 1 shows examples of strapping arrangements.

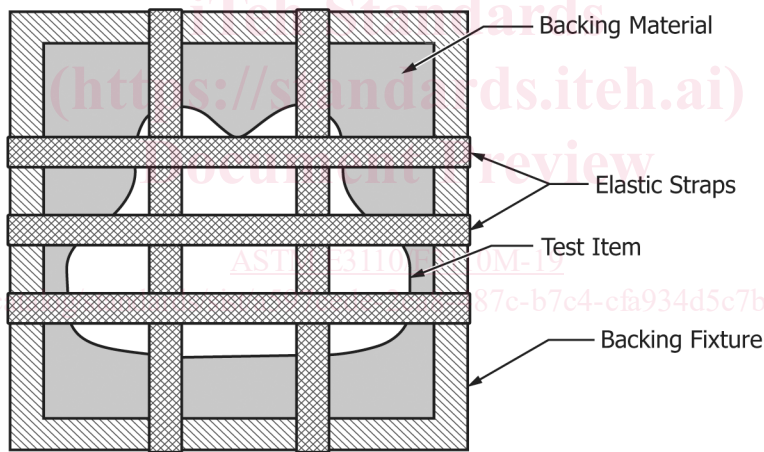

A. Strapping Arrangement for Smaller Test Items

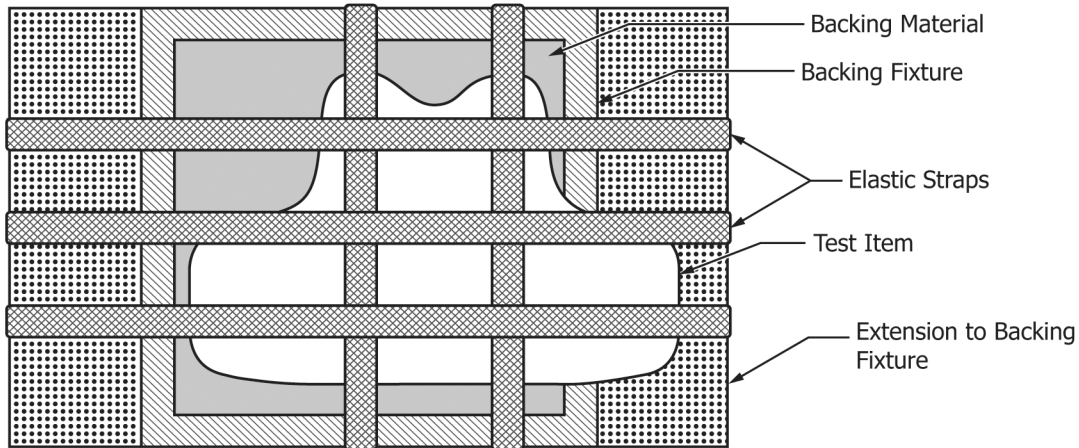

B. Strapping Arrangement for Larger Test Items Requiring Extension to Backing Fixture

FIG. 1 Examples of Strapping Arrangements

10.3 The clay block shall be positioned to achieve proper projectile impact location and angle (for example, angle of incidence, obliquity) of the test threat. For any shots requiring a nonzero angle of incidence, the clay block shall be rotated to achieve the appropriate angle.

10.4 Between test threat impacts, the test item shall be manipulated by hand so that any wrinkles or bunching in the test item (caused by a previous shot) are smoothed out.

10.4.1 No effort shall be made to recover any projectiles trapped in the test item until the test series is complete.

NOTE 5—Slight manipulation of a projectile is allowed if the projectile will interfere with subsequent shots.

10.4.2 The test item shall be repositioned on the backing material such that the test item is supported by smooth backing material for a distance of no less than 76 mm (3 in.) [3 in.] in all directions around the next shot location.

10.4.3 Instructions related to striking the backing material between shots shall be specified by other standards and specifications.

11. Mounting and Positioning of Hard Armor Test Items on a Clay Block

11.1 The test item shall be positioned on a clay block such that the entire test item is supported.

11.2 Testing of nonplanar hard armor test items on a clay block requires the use of appliques between the test item and the clay block.

NOTE 6—Testing of planar hard armor test items does not require the use of appliques.

11.2.1 The applique shall conform to the wear face of the test item and create a planar surface for the test item to contact the surface of the clay block.

NOTE 7—Practice E3086 specifies how to create appliques for nonplanar armor intended for females.

11.2.2 The applique shall be formed such that it completely fills the space between the test item and the clay block surface. The applique shall be the minimum thickness required to completely fill the space without preventing contact between the test item edges (or corners) and the surface of the clay block (for example, a multi-curve plate should have at least four points of contact between its edges and the surface of the clay block). See Fig. 2 for an example of a test item with an applique installed.

NOTE 8—A mold is necessary to create an appropriate applique sized for a specific test item, and it is possible that the hard armor could serve as the mold. Other standards and specifications may provide guidance for creating the mold and the applique and for conditioning the applique prior to use. Some testing requires that the hard armor be tested with soft armor or a shoot pack (that is, in conjunction with armor). In those cases, the hard armor shall be placed appropriately in contact with the soft armor or a shoot pack (placed on the front or inserted).

11.2.3 The applique shall be placed in intimate contact with the clay block prior to testing, and a modicum of force shall be applied to hold the applique in position.

11.2.3.1 When necessary to further secure the applique to the clay block, hand form conditioned clay into a long, thin strip. Place the strip around portions of the perimeter of the applique at the interface with the clay block, and press the clay strip into the interface to ensure that the applique remains adhered to the clay block during testing.

11.2.3.2 Care is required to ensure that the shape of the applique is not significantly changed during affixing it to the clay block.

11.3 The test item shall be positioned on a clay block (with or without an applique installed, as appropriate) such that the entire test item is supported, as shown in Fig. 2.

11.4 The test item shall be held in contact with the clay block and secured using approximately 51 to 76 mm (2 to 3 in.) wide elastic straps, held closed by hook-and-loop fasteners. Vertical and horizontal straps shall be positioned such that they do not interfere with the impact points on the test item.

11.5 The clay block shall be positioned to achieve proper projectile impact location and angle of incidence of the test threat. For any shots requiring a nonzero angle of incidence, the clay block shall be rotated to achieve the appropriate angle.

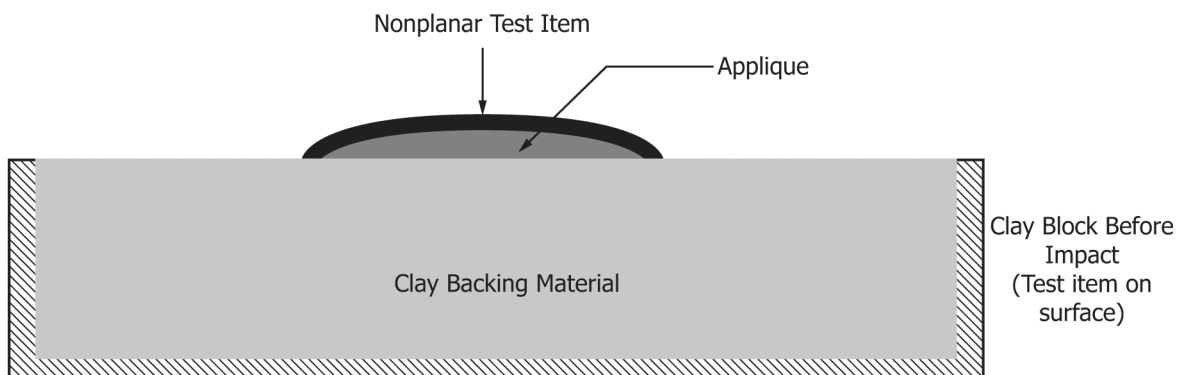

FIG. 2 Example of Test Item with Applique Installed

11.6 Between test threat impacts, any soft armor backing shall be manipulated by hand so that any wrinkles or bunching in the test item (caused by a previous shot) are smoothed out. No effort shall be made to recover any projectiles trapped in the test item until the test series is complete.

NOTE 9—Slight manipulation of a projectile is permitted if the projectile will interfere with subsequent shots.

12. Mounting of Test Items in a Frame

12.1 The test item shall be sandwiched in a frame and restrained with mechanical or pneumatic clamping devices either at the center of each side of the frame or at each corner of the frame.

12.2 The witness panel shall be positioned behind and parallel to the test item. The witness panel distance to the test item shall be specified in other standards and specifications. If no specification is listed, securely mount the witness panel 150 ± 25 mm (~~6[6.0 ± 1-in.]1.0 in.~~) behind the area of impact.

12.3 Between test threat impacts on soft armor, the test item shall be removed from the frame and manipulated by hand so that any wrinkles or bunching in the test item (caused by a previous shot) are smoothed out. No effort shall be made to recover any projectiles trapped in the test item until the test series is complete unless the projectile or fragment interferes with the clamping mechanism in such a way that would result in unequal pressure applied to all sides of the test item.

NOTE 10—Slight manipulation of a projectile is allowed if the projectile will interfere with subsequent shots.

13. V₅₀ Ballistic Limit Procedure: Up-Down Method Based on MIL-STD-662F

13.1 This method is intended for determining the V₅₀ ballistic limit and is not appropriate for determining other ballistic limit values.

13.2 *Test Procedure Requirements:*

13.2.1 A complete V₅₀ ballistic limit test series consists of successful individual ballistic tests being conducted on a number of test items.

13.2.2 The test procedure shall result in an equal number of the highest partial penetration velocities and the lowest complete penetration velocities, which occur within a specified velocity range.

13.2.2.1 The required number of highest partial penetrations and lowest complete penetrations shall be specified by other standards and specifications, and typical numbers and the maximum allowable velocity range are listed in **Table 1**.

13.2.2.2 The number of test items to be provided for the above shots shall be specified by other standards and specifications.

13.2.3 Unless specified elsewhere, the starting velocity shall be 23 to 30 m/s (~~75[75 to 100 ft/s]ft/s~~) above the minimum required V₅₀ as specified in other standards and specifications.

13.2.4 The intended angle of incidence for all shots shall be specified in other standards and specifications.

13.2.5 Firing shall be done using a random pattern of impact sites, unless specified otherwise in other standards and specifications.

13.2.6 For every shot, verify that the shot was a fair hit (per Section 9 of this test method), taking the following steps:

13.2.6.1 The velocity shall be checked to determine whether it was within the specified range.

13.2.6.2 The difference between the velocity readings from each independent instrument shall be compared as specified in Specification ~~E3062E3062/E3062M~~.

13.2.6.3 The shot spacing shall be assessed to determine if shot-to-edge, shot-to-shot, and shot-to-clay block edge or shot-to-frame/clamp edge distances meet specified requirements.

13.2.6.4 If the shot is determined to be unfair, another shot shall be taken on that test item in a location that meets shot spacing requirements. If there is not sufficient room to take the required shots, then other standards or specifications shall specify the appropriate course of action.

13.3 *Steps:*

13.3.1 Mount the test item in a frame as specified in Section 12.

13.3.2 Fire the first test threat at the test item.

TABLE 1 Typical Numbers and Maximum Allowable Velocity Ranges

Label	Number of Highest Partial Penetrations	Number of Lowest Complete Penetrations	Maximum Allowable Velocity Range
2 × 2	<u>2</u>	<u>2</u>	<u>18 m/s (60 ft/s)</u>
2 × 2	<u>2</u>	<u>2</u>	<u>18 m/s [60 ft/s]</u>
3 × 3	<u>3</u>	<u>3</u>	<u>38 m/s (125 ft/s)</u>
3 × 3	<u>3</u>	<u>3</u>	<u>38 m/s [125 ft/s]</u>
5 × 5	<u>5</u>	<u>5</u>	<u>46 m/s (150 ft/s)</u>
5 × 5	<u>5</u>	<u>5</u>	<u>46 m/s [150 ft/s]</u>