



Designation: **D4761 – 18** **D4761 – 19**

Standard Test Methods for Mechanical Properties of Lumber and Wood-Based Structural Materials¹

This standard is issued under the fixed designation D4761; the number immediately following the designation indicates the year of original adoption or, in the case of revision, the year of last revision. A number in parentheses indicates the year of last reapproval. A superscript epsilon (ϵ) indicates an editorial change since the last revision or reapproval.

INTRODUCTION

Numerous evaluations of the mechanical properties of wood-based structural materials have been satisfactorily conducted since the late 1920s, using Test Methods **D198**. Those methods are best suited to a laboratory environment and are adaptable to a variety of products such as stress-graded lumber, sawn timber, laminated timbers, wood-plywood composite members, reinforced and pre-stressed timbers.

The procedures presented in these test methods have been derived from those set forth in Test Methods **D198**. They are intended primarily for application to stress-graded lumber, but can be used for other wood-based structural materials as well. The procedures are more flexible than those in Test Methods **D198**, making testing in a non-laboratory environment more feasible. Thus the test methods can be used on production sites for field testing and quality control, as well as in laboratories for research applications. Key differences from Test Methods **D198** are the testing speed, the deflection-measuring procedures for specimens under load, and the detail of data reporting. Furthermore, the test methods do not require that specimens be loaded to failure.

Since these test methods allow latitude in testing procedures, the procedures used shall be fully documented in the test report. It may also be desirable to correlate the results from tests carried out according to these test methods with test results obtained using a traditional procedure, such as that set forth in Test Methods **D198**.

1. Scope

1.1 These test methods cover the determination of the mechanical properties of stress-graded lumber and other wood-based structural materials.

1.2 These test methods appear in the following order:

	Section
Bending edge-wise	6
Bending flat-wise:	
Center-point loading	7
Third-point loading	8
Axial strength in tension	9
Axial strength in compression	10

1.3 *This standard does not purport to address all of the safety concerns, if any, associated with its use. It is the responsibility of the user of this standard to establish appropriate safety, health, and environmental practices and determine the applicability of regulatory limitations prior to use.*

1.4 *This international standard was developed in accordance with internationally recognized principles on standardization established in the Decision on Principles for the Development of International Standards, Guides and Recommendations issued by the World Trade Organization Technical Barriers to Trade (TBT) Committee.*

¹ These test methods are under the jurisdiction of ASTM Committee **D07** on Wood and are the direct responsibility of Subcommittee **D07.01** on Fundamental Test Methods and Properties.

Current edition approved Nov. 1, 2018; April 1, 2019. Published March 2019; May 2019. Originally approved in 1988. Last previous edition approved in 2013 as **D4761 – 13**; **D4761 – 18**. DOI: [10.1520/D4761-18](https://doi.org/10.1520/D4761-18); [10.1520/D4761-19](https://doi.org/10.1520/D4761-19).

2. Referenced Documents

2.1 *ASTM Standards:*²

- [D9 Terminology Relating to Wood and Wood-Based Products](#)
- [D198 Test Methods of Static Tests of Lumber in Structural Sizes](#)
- [D2915 Practice for Sampling and Data-Analysis for Structural Wood and Wood-Based Products](#)
- [D4442 Test Methods for Direct Moisture Content Measurement of Wood and Wood-Based Materials](#)
- [D7438 Practice for Field Calibration and Application of Hand-Held Moisture Meters](#)
- [E4 Practices for Force Verification of Testing Machines](#)
- [E6 Terminology Relating to Methods of Mechanical Testing](#)
- [E177 Practice for Use of the Terms Precision and Bias in ASTM Test Methods](#)

2.2 *Other Document:*³

- [NIST Voluntary Product Standard PS20 American Softwood Lumber Standard](#)

NOTE 1—The current version of PS20 is given as an example of a product standard applicable to stress-graded lumber. Other product standards may apply to stress-graded lumber. For wood-based structural materials other than stress-graded lumber, relevant product standards may apply.

3. Terminology

3.1 *Definitions*—See Terminologies [D9](#) and [E6](#) and Practices [E4](#) and [E177](#) for definitions of terms used in these test methods.

3.2 *Definitions of Terms Specific to This Standard:*

3.2.1 *breadth*—in a bending test, that dimension of the specimen in the direction perpendicular to the span and perpendicular to the direction of an applied load.

3.2.2 *depth*—in a bending test, that dimension of the specimen in the direction perpendicular to the span and parallel to the direction of an applied load.

3.2.3 *span*—in a bending test, the distance between the center lines of the pivot points upon which the specimen is supported to accommodate a transverse load.

4. Significance and Use

4.1 These test methods provide procedures that are applicable under true field conditions, such as in a plant with specimens not at moisture equilibrium.

4.2 The data established by these test methods can be used as follows:

4.2.1 Develop strength and stiffness properties for the population represented by the material being tested (that is, individual grades, grade combinations, species, species groups, or any other defined, identifiable sample).

4.2.2 Confirm the validity of strength and stiffness properties for the population represented by the material being tested.

4.2.3 Investigate the effect of parameters that have the potential to influence the strength and stiffness properties of the material, such as moisture content, temperature, knot size and location, or slope of grain.

4.3 The procedures chosen in accordance with these test methods shall be fully documented in the report to facilitate correlation with test results obtained through the use of traditional procedures, such as those set forth in Test Methods [D198](#).

5. Precision and Bias

5.1 The precision and bias of these test methods have not yet been established.

6. BENDING EDGE-WISE—THIRD-POINT LOADING

6.1 *Scope*

6.1.1 This test method provides procedures for the determination of the strength and modulus of elasticity of stress-graded lumber and other wood-based structural materials in bending edge-wise, where the member depth is typically greater than or equal to the member breadth.

NOTE 2—The use of the terms “edge-wise” and “flat-wise” in these test methods are intended to refer to the geometric limitations described above. They are not intended to mandate that the “joist,” “edge,” “flat,” or “plank” orientation of a composite product needs to be tested using a specific specimen geometry or protocol.

6.2 *Summary of Test Methods*

6.2.1 The specimen is simply supported and loaded by two equal transverse concentrated loads equidistant from the reaction points and each other. The specimen is loaded at a prescribed rate with observation of load and/or deflection until failure occurs

² For referenced ASTM standards, visit the ASTM website, www.astm.org, or contact ASTM Customer Service at service@astm.org. For *Annual Book of ASTM Standards* volume information, refer to the standard’s Document Summary page on the ASTM website.

³ Available from National Institute of Standards and Technology (NIST), 100 Bureau Dr., Stop 3460, Gaithersburg, MD 20899-3460.

or a pre-selected load or deflection is reached. The load and corresponding deflection are recorded when bending stiffness is to be determined. Only the load is measured if the objective of the test is to determine the specimen strength.

6.3 Apparatus

6.3.1 *Testing Machine*—A device that combines (1) a reaction frame to support the specimen, (2) a loading mechanism for applying load at a specified rate, and (3) a force-measuring apparatus that can be calibrated to the accuracy requirements of 6.3.3.2 following the procedures outlined in Practices E4.

6.3.1.1 *Load and Reaction Apparatus*—The load and reaction apparatus shall include bearing plates at the load and reaction points that are at least as wide as the specimen breadth and not exceeding the member depth in length. These bearing plates shall have eased edges and sufficient bearing length to avoid a localized crushing failure at the load and reaction points. The apparatus shall also include appropriate mechanisms, such as rollers, to minimize the development of axial forces in the specimen. Each load and reaction point shall include an in-plane pivot point. Bearing plates and rollers shall be initially centered about their pivot points.

6.3.1.2 *Loading Configuration*—The specimen shall be simply supported and loaded by two equal transverse concentrated loads equidistant from the reaction points and each other.

NOTE 3—The apparent modulus of elasticity varies for different loading configurations (see Practice D2915). While the loading configuration that commonly serves as the basis for design assumes a uniformly distributed load, a configuration with two concentrated loads symmetrically placed within the span is usually more suitable for structural tests to determine bending capacity and develop related design values. This configuration also produces a constant bending moment, free of shear, in the portion of the specimen between the load points.

6.3.1.3 *Lateral Supports*—When necessary to restrict specimen out-of-plane displacement, lateral supports shall be used. Specimens having a depth-to-breadth ratio of three or greater are subject to lateral instability during loading and shall be evaluated for adequate lateral support. Any provided lateral supports shall restrain out-of-plane displacement, but allow movement of the specimen in the direction of load application with minimal frictional or other in-plane restraint.

6.3.2 *Deflection-Measuring Apparatus*—A measurement device shall be used to monitor the deflection of the specimen when the bending stiffness is to be determined. Deflection shall be permitted to be measured directly as the displacement of the loading head of the testing machine or as direct measurement of the specimen movement relative to the reaction frame at mid-span. In the former case, deflection is expressed as the average displacement of the ~~load-bearing~~ load-bearing plates with respect to the ~~reaction bearing~~ reaction-bearing plates. If, because of the design of the apparatus, the deflection measurement includes extraneous components, the deflection data shall be permitted to be adjusted for such extraneous components. However, if the extraneous components are an appreciable portion of the total measurement, then the test apparatus shall be re-examined for its suitability. In all instances, the report shall include a complete description of test conditions, extraneous components, and data adjustment procedures.

NOTE 4—Possible sources of extraneous components of deflection with either measurement type might include: flexure of the load and reaction frame components, slack or looseness in the fixture connections, crushing of the material surface at the bearing plates, and/or geometric imperfections of the tested material. These factors typically result in an overestimation of the member deflection and a conservative underestimation of the measured stiffness. ~~Adjustment factors, if used to remove some of this conservatism,~~ Provided test results with extraneous components are repeatable over the range of materials typically tested, adjustment factors to remove this bias may be developed based upon matched correlations for similar tests of similar materials using Test Methods D198. As an alternative, a mid-span yoke-mounted deflection device similar to that described by Test Methods D198 may be used with these procedures to improve accuracy and mitigate the need for adjustment.

6.3.3 Accuracy:

6.3.3.1 The two load points shall be located within $\pm 1/16$ in. (1.6 mm) of the position determined in accordance with 6.3.1.2 and 6.4.2.2.

6.3.3.2 The force-measuring apparatus shall be such as to permit load measurements with an error not to exceed ± 1.0 % of the load for loads greater than or equal to 1000 lbf (4450 N). For loads smaller than 1000 lbf, the error shall not exceed ± 10 lbf (45 N).

6.3.3.3 The deflection-measuring apparatus shall be such as to permit deflection measurements with an error not to exceed ± 1.0 % of the deflection with deflections greater than or equal to 0.150 in. (4 mm).

NOTE 5—Bending stiffness estimates obtained from total specimen deflections of 0.150 in. (4 mm) or less have a significant measurement error component and are not recommended.

6.3.3.4 The cross-sectional dimensions of the member shall be measured to ~~an accuracy of~~ at least three significant figures.

6.4 Specimen

6.4.1 *Cross Section*—Unless the effect of cross-section modifications is a test evaluation objective, the specimen shall be tested without modifying the dimensions of the commercial cross section.

6.4.2 Length:

6.4.2.1 The minimum specimen length shall be the span, determined in accordance with 6.4.2.2, plus an extension beyond the center lines of the end reactions, such that the specimen will not slip off the bearing plates at the end reactions during the test. In cases where the unsupported specimen length outside the span at an end reaction (overhang) exceeds ~~10~~ ten times the specimen depth, report the amount of overhang at each end reaction.

6.4.2.2 The span depends on the purpose of the test program. It is customary to express the span as a multiple of the specimen ~~depth—depth~~. While spans that currently serve as a basis suitable for testing range from 17 to 21 times the depth of the specimen, other spans shall be permitted. ~~Practice D2915 gives an indication of the impact that varying span-to-depth ratios have upon the measured member stiffness.~~

~~NOTE 6—Practice D2915~~The depth here gives an indication of the impact that varying span-to-depth ratios have upon the measured member stiffness. The depth in this section refers to the relevant size specified in the size classification of the applicable product standard. As an example for stress-graded lumber, the depth used to determine the span will typically be the dressed dry size specified in the size classification of the current version of PS20. For example, 3.5 in. (89 mm) should be used to calculate the span-to-depth ratio for members with a nominal depth of 4 in. ~~(102 mm)~~.

6.4.3 *Conditioning*—Specimens shall be permitted to be tested as produced or conditioned (for example, temperature, moisture content, or treatment), depending on the purpose of the test program. If the temperature of the specimens at the time of testing is less than ~~45°F (7°C)~~ 45 °F (7 °C) or more than ~~90°F (32°C)~~ 90 °F (32 °C), that temperature shall be reported.

6.5 Procedure

6.5.1 Specimen Measurements:

6.5.1.1 Before testing, measure and record the cross-sectional dimensions of every specimen at the center of the span unless another location is more appropriate to the purpose of the test.

6.5.1.2 Following the test, measure the moisture content of the specimens at a location away from the ends and as close to the failure zone as practical in accordance with the procedures outlined in Test Methods **D4442** or using a calibrated moisture meter according to Practice **D7438**. The number of moisture content samples shall be determined using Practice **D7438** guidelines, with consideration of the expected moisture content variability, and any related requirements in the referenced product standards.

6.5.2 *Lengthwise Positioning*—The positioning of the specimen across the span with respect to specific specimen characteristics shall be addressed by a within-piece sampling plan for the test program. The procedure shall be documented and the resulting specimen length shall comply with the provisions of **6.4.2**. The plan shall also detail how the tension edge is selected.

~~NOTE 7—Two possible approaches used for lengthwise positioning may be to locate the specimen across the span without bias regarding defects or to locate specific defects near the center of the span and to deliberately or randomly position a defect at the tension or compression side of the specimen, depending upon the test objectives.~~

6.5.3 *Speed of Testing*—The test rate shall be such that the sample target failure load is achieved in approximately 1 min. It is recommended that the failure load be reached in not less than 10 s nor more than 10 min.

~~NOTE 8—Some caution is warranted here. A test rate to achieve the average failure load for the sample in approximately 1 min will differ from that to achieve a lower percentile load for the same sample in approximately 1 min.~~

~~NOTE 9—For stress-graded lumber, a rate of motion of the testing machine loading head of approximately 3 in. (76 mm)/min will usually permit the test to be completed in the prescribed time for ~~span-to-depth~~ span-to-depth ratios of 17:1 and in cases where the target failure load is the average failure load for the sample.~~

6.5.4 *Load-Deflection Data*—Obtain load-deflection data, if required, using the apparatus specified in **6.3.2**.

~~NOTE 10—Load and deflection data should be captured to define the linear stiffness and at least include the design load range of the product being tested. Capturing the data from 10 to ~~40%~~ 40 % of the expected maximum load is typically sufficient to achieve this goal. For stress-graded lumber, data obtained for loads corresponding to maximum stresses in the specimen ranging from 400 to 1000 psi (3 to 7 MPa) will usually be adequate for stiffness calculations.~~

6.5.5 *Maximum Load*—If the purpose of the test is to determine strength properties, record the maximum load attained in the test.

~~NOTE 11—In proof loading, the intended load target may not be reached or may be exceeded slightly. The target load should be reported along with the actual attained load.~~

6.5.6 *Record of Failure*—For a destructive test, describe the characteristic causing failure, and its location within the span.

~~NOTE 12—An example of a coding scheme for recording characteristic type and failure location in stress-graded lumber is given in **Appendix XI**.~~

6.6 Report

6.6.1 The report content depends on the purpose of the test program. The report shall include, at the minimum, the following information:

6.6.1.1 Description of the testing machine, including a drawing or photograph of the test setup, the span, fixturing, and the deflection-measuring apparatus, if applicable.

6.6.1.2 Description of calibration procedures, frequency, and records.

6.6.1.3 Method used for the measurement of the moisture content of specimens.

6.6.1.4 Speed of testing and means of control of the speed of testing.

6.6.1.5 Specimens lengthwise positioning and selection of the tension edge.

6.6.1.6 As applicable, the type of load-deflection data for the calculation of the stiffness of specimens, including a description of test conditions, extraneous components, and data adjustment procedures in accordance with **6.3.2**.

6.6.1.7 Description of the population sampled, in accordance with Practice **D2915**.

6.6.1.8 Description of the sample, including (1) sample size, (2) conditioning, if applicable, (3) temperature of specimens at the time of testing, and (4) number of specimens that failed during the test.

6.6.1.9 Data on specimens, including, as applicable, (1) grade, (2) actual cross-sectional dimensions, (3) moisture content, (4) overhang in accordance with 6.4.2.1, (5) load-deflection data, (6) maximum load, (7) time to maximum load, and (8) failure description and location.

NOTE 13—The Appendices of Test Methods D198 provide equations that may be employed to further convert this data into modulus of rupture, modulus of elasticity, and other useful normalized quantities depending upon the test objectives.

6.6.1.10 Details of any deviations from the prescribed or recommended procedures as outlined in this test method.

7. BENDING FLAT-WISE—CENTER-POINT LOADING

7.1 Scope

7.1.1 This test method provides procedures for the determination of long-span modulus of elasticity of lumber and other wood-based structural materials in flat-wise bending under center-point load, where the member breadth is typically greater than the member depth (Note 2).

7.2 Determination of Long-Span Modulus of Elasticity

7.2.1 Long-span modulus of elasticity (E) is defined as the modulus of elasticity calculated from deflection measured in a flat-wise test with center point loading and a span-depth ratio (L/h) of approximately $\pm 100 \pm 10 \pm 100 \pm 10$.

NOTE 14—The long-span E is sometimes used to estimate the member modulus of elasticity with minimized influence from shear deflection.

7.3 Summary of the Test Method

7.3.1 A known concentrated transverse load is applied at mid-span of a simply supported specimen oriented flatwise. A displacement measurement device is used to determine the deflection of the specimen under the load. The modulus of elasticity (E) is determined by relating the applied load and deflection to the size of specimen and the span.

7.4 Apparatus

7.4.1 *Support System*—Any support system shall be permitted that provides unrestrained support at both end reactions. The reaction point at one end shall be constructed so that stability is provided for a piece of twisted lumber, such as a pedestal with a single point reaction, a reaction point that is designed to tilt to match the twist of the lumber, or special shims that restrain the specimen from rocking on the reaction supports. Each load or reaction point shall include an in-plane pivot point. Bearing plates, when employed, shall be initially centered about their pivot points.

7.4.2 Accuracy

7.4.2.1 *Span*—The load point shall be located within $\pm 1/16$ in. (1.6 mm) of the position determined in accordance with 7.2.1 and 7.5.1.

7.4.2.2 *Test Loads*—Weights used for test loads shall be compact and known to an accuracy of ± 0.05 lbm (23 g).

7.4.2.3 *Deflection-Measuring Apparatus*—The specimen deflection shall be measured using a device with the capacity to measure displacement up to at least 1 in. (25 mm) with an accuracy of $\pm 1\%$.

7.4.2.4 The cross-sectional dimensions of the member shall be measured to at least three significant figures.

7.4.3 A weight of approximately 5.0 lbm. (2.3 kg) shall be used for pre-loading. Further weights in 5.0 or 10.0 lbm. (2.3 to 4.5 kg) increments shall be used to apply test loads.

NOTE 15—Three 5-lbm. (2.3 kg) weights and one 10-lbm. (4.5 kg) weight have been found to provide an adequate combination of weights for nominal 2 by 4 through nominal 2 by 12 surfaced dimension lumber sizes.

7.5 Specimen

7.5.1 *Cross Section*—Unless the effect of cross-section modifications is a test evaluation objective, the specimen shall be tested without modifying the dimensions of the commercial cross section.

7.5.2 *Length*—The minimum specimen length shall be the span, determined in accordance with 7.6.2 plus an extension beyond the center lines of the end reactions, such that the specimen will not slip off the bearing plates at the end reactions during the test.

7.5.3 *Conditioning*—The procedures of 6.4.3 shall be followed.

7.6 Procedure

7.6.1 *Specimen Measurements*—The procedures of 6.5.1 shall be followed.

7.6.2 Space the reaction points to provide a span-to-depth ratio for the specimen of approximately $\pm 100 \pm 10 \pm 100 \pm 10$ for use in the calculation of the modulus of elasticity. The span used shall be recorded.

7.6.3 Place the displacement measurement device midway between the reaction points and adjust it so the downward deflection of the specimen can be measured when loaded. Construct or arrange the apparatus such that the relative position of the deflection measurement device to the reaction points is not changed more than 0.001 in. (0.025 mm) when the load weight is placed on the specimen.

7.6.4 Place the specimen flatwise on the reaction points and in firm contact with both end reactions.

7.6.5 Apply the 5.0 lbm (2.3 kg) pre-load weight to the specimen at or near mid-span and either tare the deflection measurement device or take an immediate reading.

7.6.6 Load the specimen at mid-span and immediately take a deflection measurement device reading. This load shall be such that it will induce approximately 0.2 in. (5 mm) or more deflection.

7.6.7 Determine and record the deflection of the specimen due to the load applied in 7.6.6.

7.6.8 Long-span modulus of elasticity is determined using the following equation:

$$E = PL^3 / (48\Delta I)$$

where:

E = modulus of elasticity, psi (MPa),

P = increment of applied load in 7.6.6, lbf (N),

L = span, in. (mm),

Δ = increment of deflection from 7.6.7 corresponding to the increment of applied load, in 7.6.6, in. (mm), and

I = moment of inertia, in.⁴ (mm⁴).

7.7 Report

7.7.1 The content of the report depends on the purpose of the test program. The report shall include, at the minimum, all applicable information as presented in 6.6.

8. BENDING FLAT-WISE—THIRD-POINT LOADING

8.1 Scope

8.1.1 This test method provides procedures for the determination of bending strength and stiffness of stress-graded lumber and other wood-based structural materials in flat-wise bending on short spans under third-point load, where the member breadth is typically greater than the member depth (Note 2).

8.2 Summary of the Test Methods

8.2.1 The specimen is simply supported and loaded on the wide face by two equal transverse concentrated loads equidistant from the reaction points and each other. The specimen is loaded at a prescribed rate with observation of load and/or deflection until failure occurs or a preselected load or deflection is reached. The load and corresponding deflection are recorded when bending stiffness is to be determined. Only the load is measured if the objective of the test is to determine or verify the specimen strength.

8.2.2 If the data collection is only to determine specimen stiffness, then a step-wise load shall be permitted that includes pre-loading and then adding a known weight for deflection measurement.

8.3 Apparatus

8.3.1 *Testing Machine*—A device that combines (††) a reaction frame to support the specimen; (††) a loading mechanism for applying load at a specified rate or prescribed load interval; and (††) a force-measuring apparatus that can be calibrated to the requirements of 8.3.3.2, following the procedures outlined in Practices E4. If the test is used only to determine member bending stiffness using known weights, then a force-measuring device is not specifically required. Fig. 1 illustrates the traditional device meeting the requirements of these test methods for bending stiffness measurement using a known test load.

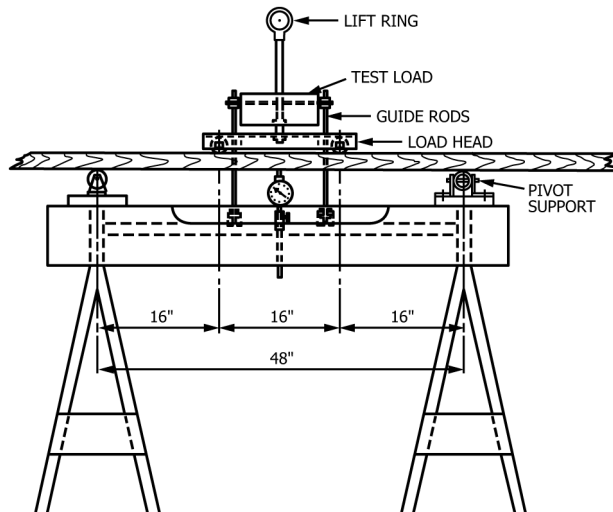

16 in. = 410 mm
48 in. = 1220 mm

This device is used for assessment of bending stiffness in third-point, flat-wise bending on a span-to-depth ratio of 32 for 1½-in. (38-mm) thick lumber.

FIG. 1 Schematic of Static Third-Point Bending Testing Device