



Designation: **E748 – 16 E748 – 19**

Standard Guide for Thermal Neutron Radiography of Materials¹

This standard is issued under the fixed designation E748; the number immediately following the designation indicates the year of original adoption or, in the case of revision, the year of last revision. A number in parentheses indicates the year of last reapproval. A superscript epsilon (ϵ) indicates an editorial change since the last revision or reapproval.

1. Scope*

1.1 *Purpose*—Practices to be employed for the radiographic examination of materials and components with thermal neutrons are outlined herein. They are intended as a guide for the production of neutron radiographs that possess consistent quality characteristics, as well as aiding the user to consider the applicability of thermal neutron radiology. Statements concerning preferred practice are provided without a discussion of the technical background for the preference. The necessary technical background can be found in Refs **(1-16)**.²

1.2 *Limitations*—Acceptance standards have not been established for any material or production process (see Section 5 on Basis of Application). Adherence to the guide will, however, produce reproducible results. Neutron radiography, whether performed by means of a reactor, an accelerator, subcritical assembly, or radioactive source, will be consistent in sensitivity and resolution only if the consistency of all details of the technique, such as neutron source, collimation, geometry, film, etc., are maintained. This guide is limited to the use of photographic or radiographic film in combination with conversion screens for image recording; other imaging systems are available. Emphasis is placed on the use of nuclear reactor neutron sources.

1.3 *Interpretation and Acceptance Standards*—Interpretation and acceptance standards are not covered by this guide. Designation of accept-reject standards is recognized to be within the cognizance of product specifications.

1.4 *Safety Practices*—General practices for personnel protection against neutron and associated radiation peculiar to the neutron radiologic process are discussed in Section **E718**. Jurisdictional nuclear regulations will also apply.

1.5 *Other Aspects of the Neutron Radiographic Process*—For many important aspects of neutron radiography such as technique, files, viewing of radiographs, storage of radiographs, film processing, and record keeping, refer to Guide **E94**, which covers these aspects for ~~x-ray~~**X-ray** radiography. (See Section 2.)

1.6 The values stated in either SI or inch-pound units are to be regarded as the standard.

1.7 *This standard does not purport to address all of the safety concerns, if any, associated with its use. It is the responsibility of the user of this standard to establish appropriate safety, health, and environmental practices and determine the applicability of regulatory limitations prior to use.*

1.8 *This international standard was developed in accordance with internationally recognized principles on standardization established in the Decision on Principles for the Development of International Standards, Guides and Recommendations issued by the World Trade Organization Technical Barriers to Trade (TBT) Committee.*

2. Referenced Documents

2.1 ASTM Standards:³

E94 Guide for Radiographic Examination Using Industrial Radiographic Film

E543 Specification for Agencies Performing Nondestructive Testing

E545 Test Method for Determining Image Quality in Direct Thermal Neutron Radiographic Examination

E803 Test Method for Determining the *L/D* Ratio of Neutron Radiography Beams

E1316 Terminology for Nondestructive Examinations

¹ These practices are under the jurisdiction of ASTM Committee **E07** on Nondestructive Testing and are the direct responsibility of Subcommittee **E07.05** on Radiology (Neutron) Method.

Current edition approved Feb. 15, 2016; May 1, 2019. Published February 2016; June 2019. Originally approved in 1980. Last previous edition approved in 2008 as **E748 – 02 E748 – 16** (2008). DOI: 10.1520/E0748-16.10.1520/E0748-19.

² The boldface numbers in parentheses refer to the list of references at the end of this standard.

³ For referenced ASTM standards, visit the ASTM website, www.astm.org, or contact ASTM Customer Service at service@astm.org. For *Annual Book of ASTM Standards* volume information, refer to the standard's Document Summary page on the ASTM website.

*A Summary of Changes section appears at the end of this standard

2.2 ASNT Standard:⁴

Recommended Practice SNT-TC-1A for Personnel Qualification and Certification

2.3 ANSI Standard:⁵

ANSI/ASNT-CP-189 Standard for Qualification and Certification of Nondestructive Testing Personnel

2.4 AIA Document:⁶

NAS-410 Nondestructive Testing Personnel Qualification and Certification

2.5 ISO Standard:⁷

ISO 9712 Non-Destructive Testing—Qualification and Certification of NDT Personnel

3. Terminology

3.1 *Definitions*—For definitions of terms used in these practices, see Terminology **E1316**, Section H.

4. Significance and Use

4.1 This guide covers types of materials to be examined, neutron radiographic examination techniques, neutron production and collimation methods, radiographic film, and converter screen selection. Within the present state of the neutron radiologic art, these practices are generally applicable to specific material combinations, processes, and techniques.

5. Basis of Application

5.1 *Personnel Qualification*—If specified in the contractual agreement, personnel performing examinations to this standard shall be qualified in accordance with a nationally or internationally recognized NDT personnel qualification practice or standard such as ANSI/ASNT-CP-189, SNT-TC-1A, NAS-410, ISO 9712, or a similar document and certified by the employer or certifying agency, as applicable. The practice or standard used and its applicable revision shall be identified in the contractual agreement between the using parties.

5.2 *Qualification of Nondestructive Agencies*—If specified in the contractual agreement, NDT agencies shall be qualified and evaluated as described in **Practice Specification E543**. The applicable edition of **Practice Specification E543** shall be specified in the contractual agreement.

5.3 *Procedures and Techniques*—The procedures and techniques to be used shall be as described in these practices unless otherwise specified. Specific techniques may be specified in the contractual agreement.

5.4 *Reporting Criteria/Acceptance Criteria*—Reporting criteria for the examination results shall be in accordance with **1.3** unless otherwise specified. Acceptance criteria (for example, for reference radiographs) shall be specified in the contractual agreement.

6. Neutron Radiography

6.1 *The Method*—Neutron radiography is basically similar to X-ray radiography in that both techniques employ radiation beam intensity modulation by an object to image macroscopic object details. X-rays or gamma rays are replaced by neutrons as the penetrating radiation in a through-transmission examination. Since the absorption characteristics of matter for X-rays and neutrons differ drastically, the two techniques in general serve to complement one another.

6.2 *Facilities*—The basic neutron radiography facility consists of a source of fast neutrons, a moderator, a gamma filter, a collimator, a conversion screen, a film image recorder or other imaging system, a cassette, and adequate biological shielding and interlock systems. A schematic diagram of a representative neutron radiography facility is illustrated in **Fig. 1**.

7. Neutron Sources

7.1 *General*—The thermal neutron beam may be obtained from a nuclear reactor, a subcritical assembly, a radioactive neutron source, or an accelerator. Neutron radiography has been achieved successfully with all four sources. In all cases the initial neutrons generated possess high energies and must be reduced in energy (moderated) to be useful for thermal neutron radiography. This may be achieved by surrounding the source with light materials such as water, oil, plastic, paraffin, beryllium, or graphite. The preferred moderator will be dependent on the constraints dictated by the energy of the primary neutrons, which will in turn be dictated by neutron beam parameters such as thermal neutron yield requirements, cadmium ratio, and beam gamma ray contamination. The

⁴ Available from the American Society for Nondestructive Testing, 1711 Arlingate Lane, Testing (ASNT), P.O. Box 28518, 1711 Arlingate Ln., Columbus, OH 43228-0518, 43228-0518, <http://www.asnt.org>.

⁵ Available from American National Standards Institute (ANSI), 25 W. 43rd St., 4th Floor, New York, NY 10036-10036, <http://www.ansi.org>.

⁶ Available from Aerospace Industries Association of America, Inc., 1250 Eye St., NW, Washington, DC 20005-1101, (AIA), 1000 Wilson Blvd., Suite 1700, Arlington, VA 22209, <http://www.aia-aerospace.org>.

⁷ Available from American National Standards Institute (ANSI), 25 W. 43rd St., 4th Floor, New York, NY 10036, <http://www.ansi.org>.

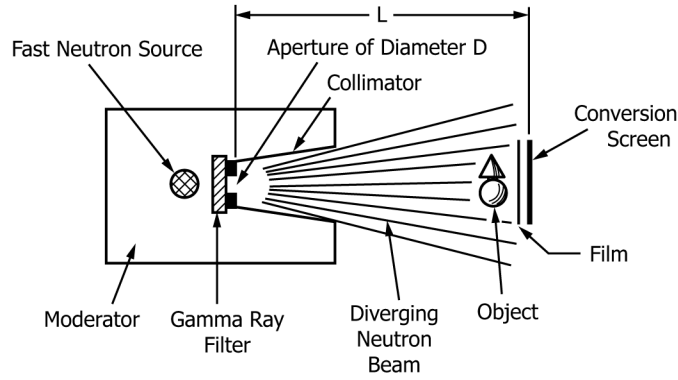

FIG. 1 Typical Neutron Radiography Facility with Divergent Collimator

characteristics of a particular system for a given application are left for the seller and the buyer of the service to decide. Characteristics and capabilities of each type of source are referenced in the References section. A general comparison of sources is shown in Table 1.

7.2 Nuclear Reactors—Nuclear reactors are the preferred thermal neutron source in general, since high neutron fluxes are available and exposures can be made in a relatively short time span. The high neutron intensity makes it possible to provide a tightly collimated beam; therefore, high-resolution radiographs can be produced.

7.3 Subcritical Assembly—A subcritical assembly is achieved by the addition of sufficient fissionable material surrounding a moderated source of neutrons, usually a radioisotope source. Although the total thermal neutron yield is smaller than that of a nuclear reactor, such a system offers the attractions of adequate image quality in a reasonable exposure time, relative ease of licensing, adequate neutron yield for most industrial applications, and the possibility of transportable operation.

7.4 Accelerator Sources—Accelerators used for thermal neutron radiography have generally been of the low-voltage type which utilize the $^3\text{H}(d,n)^4\text{He}$ reaction, high-energy X-ray machines in which the (x,n) reaction is applied and Van de Graaff and other high-energy accelerators which employ reactions such as $^9\text{Be}(d,n)^{10}\text{B}$. In all cases, the targets are surrounded by a moderator to reduce the neutrons to thermal energies. The total neutron yields of such machines can be on the order of $10^{12}\cdot\text{n}\cdot\text{s}^{-1}$; the thermal neutron flux of such sources before collimation can be on the order of $10^9\cdot\text{n}\cdot\text{cm}^{-2}\cdot\text{s}^{-1}$, for example, the yield from a Van de Graaff accelerator.

7.5 Isotopic Sources—Many isotopic sources have been employed for neutron radiologic applications. Those that have been most widely utilized are outlined in Table 2. Radioactive sources offer the best possibility for portable operation. However, because of the relatively low neutron yield, the exposure times are usually long for a given image quality. The isotopic source ^{252}Cf offers a number of advantages for thermal neutron radiology, namely, low neutron energy and small physical size, both of which lead to efficient neutron moderation, and the possibility for high total neutron yields.

8. Imaging Methods and Conversion Screens

8.1 General—Neutrons are indirectly ionizing particulate radiation that have little direct effect on radiographic film. To obtain a neutron radiographic image on film, a conversion screen is normally employed; upon neutron capture, screens emit prompt and delayed decay products in the form of nuclear radiation or light. In all cases the screen should be placed in intimate contact with the radiographic film in order to obtain sharp images.

8.2 Direct Method—In the direct method, a film is placed on the source side of the conversion screen (front film) and exposed to the neutron beam together with the conversion screen. Electron emission upon neutron capture is the mechanism by which the film is primarily exposed in the case of gadolinium conversion screens. The screen is generally one of the following types: (1) a free-standing gadolinium metal screen accessible to film on both sides; (2) a sapphire-coated, vapor-deposited gadolinium screen on a substrate such as aluminum; or (3) a light-emitting fluorescent screen such as gadolinium oxysulfide or $^6\text{LiF/ZnS}$. Exposure of an additional film (without object) is often useful to resolve artifacts that may appear in radiographs. Such artifacts could result from screen marks, excess pressure, light leaks, development, or non-uniform film. In the case of light-emitting conversion screens, it is recommended that the spectral response of the light emission be matched as closely as possible to that of the film used for

TABLE 1 Comparison of Thermal Neutron Sources

Type of Source	Typical Radiographic Flux, n/cm ² ·s	Radiographic Resolution	Characteristics
Nuclear reactor	10 ⁵ to 10 ⁸	excellent	stable operation, not portable
Subcritical assembly	10 ⁴ to 10 ⁶	good	stable operation, portability difficult
Accelerator	10 ³ to 10 ⁶	medium	on-off operation, transportable
Radioisotope	10 ¹ to 10 ⁴	poor to medium	stable operation, portability possible

TABLE 2 Radioactive Sources Employed for Thermal Neutron Radiography

Source	Type	Half-Life	Comments ^A
¹²⁴ Sb-Be	(γ, n)	60 days	short half-life and high γ -background, low neutron energy is advantage for moderation, high yield source
²¹⁰ Po-Be	(α, n)	138 days	short half-life, low γ -background
²⁴¹ Am-Be	(α, n)	458 years	long half-life, easily shielded γ -background
²⁴¹ Am- ²⁴² Cm-Be	(α, n)	163 days	short half-life, high neutron yield
²⁵² Cf	spontaneous fission	2.65 years	long half-life, high neutron yield, small size and low energy offer advantages in moderation

^A These comments compare sources in the table.

optimum results. The direct method should be employed whenever high-resolution radiographs are required, and high beam contamination of low-energy gamma rays or highly radioactive objects do not preclude its use.

8.3 Indirect Method—This method makes use of conversion screens that can be made temporarily radioactive by neutron capture. The conversion screen is exposed alone to the neutron-imaging beam; the film is not present. Candidate conversion materials include rhodium, gold, indium, and dysprosium. Indium and dysprosium are recommended with dysprosium yielding the greater speed and emitting less energetic gamma radiation. It is recommended that the conversion screens be activated in the neutron beam for a maximum of three half-lives. Further neutron irradiation will result in a negligible amount of additional induced activity. After irradiation, the conversion screens should be placed in intimate contact with a radiographic film in a vacuum cassette, or other light-tight assembly in which good contact can be maintained between the radiographic film and radioactive screen. X-ray intensification screens may be used to increase the speed of the auto-radiographic process if desired. For the indirect type of exposure, the material from which the cassette is fabricated is immaterial as there are no neutrons to be scattered in the exposure process. In this case, as in the activation process, there is little to be gained for conversion screen-film exposures extending beyond three half-lives. It is recommended that this method be employed whenever the neutron beam is highly contaminated with gamma rays, which in turn cause film fogging and reduced contrast sensitivity, or when highly radioactive objects are to be radiographed. In short, this method is beam gamma-insensitive.

8.4 Other Imaging Systems—The scope of this guide is limited to film detectors (see 1.2). However, other neutron detector systems such as track-etch and digital detector systems are available.

9. Neutron Collimators

9.1 General—Neutron sources for thermal neutron radiology generally involve a sizeable moderator region in which the neutron motion is highly multidirectional. Collimators are required to produce a beam and thereby produce adequate image resolution capability in a neutron radiology facility. It should be noted that in the definitions of collimator parameters, it is assumed that the object under examination is placed as close to the detector system as possible to decrease both magnification and image unsharpness due to the finite neutron source size. Several types of collimators are available. These include the widely used divergent type, multichannel, pinhole, and straight collimators. The image spatial resolution properties of the beams are generally set in part by the diameter or longest dimension of the collimator entrance port (D) and the distance between that aperture and the imaging system (L). An exception is the multichannel collimator in which D is the diameter of a channel and L is the length of the collimator. It should be noted that the detection system used in conjunction with a multichannel collimator will register the collimator pattern. Registry can be eliminated by empirically adjusting the distance between the collimator and the imaging system until the pattern disappears. Ratios of L/D as low as 10 are not unusual for low neutron yield sources, while higher resolution capability systems often will display L/D values of several hundred or more. Test Method E803 details the method of measuring the L/D ratio for neutron radiography systems. The actual spatial resolution or image unsharpness in a particular radiologic examination will depend, of course, on factors additional to the beam characteristics. These include the object size, the geometry of the system, and scatter conditions. For the typical calculation of geometric unsharpness, the size of the X-radiologic source, F , would be replaced by the size of the effective thermal neutron radiologic source (D) as discussed in Guide E94.

9.2 Divergent Collimator—The divergent collimator is a tapered reentrant port into the point of highest thermal neutron flux in the moderator. The walls of the collimator are lined with a thermal neutron absorbing material to permit only unscattered neutrons from the source to reach the object and the image plane. This type of collimator is preferred when larger objects will be radiographed in a single exposure. It is recommended that the divergent collimator be lined with a neutron absorber which produces neutron capture decay products that will not result in background fogging of the film, such as ⁶Li carbonate. A typical divergent collimating system is illustrated in the schematic diagram of Fig. 1.

9.3 Multichannel Collimator—The multichannel collimator is an array of tubular collimators stacked within a larger collimator envelope. It is recommended as a means of achieving a high degree of collimation within a short collimation length. When this type of collimator is employed, a suitable collimator to detector distance should be maintained to avoid registry of the collimator pattern on the radiologic image.

9.4 *Straight Collimator*—A straight-tube reentrant port can also be used instead of the tapered assembly described in 9.2. Although such collimators were widely used in early neutron radiologic work, the need to examine larger objects and to achieve higher resolution has fostered the use of divergent collimators.

9.5 *Pinhole Collimator*—Higher resolution can be obtained with a straight collimator when it is employed in conjunction with a pinhole iris. The pinhole is generally fabricated from a neutron-opaque material such as Cd, Gd, or ^{10}B . The resolution attainable will be dependent on the pinhole diameter D . A schematic diagram of this system is illustrated in Fig. 2.

10. Beam Filters

10.1 *Thermal Neutron Radiography*—In general, filters may not be necessary. However, it may be desirable to employ Pb or Bi filters in the neutron beam to minimize beam gamma-ray contamination. Whenever Bi gamma-ray filters are employed in a high neutron flux environment, the filter should be encased in a sealed aluminum can to contain alpha particle contamination due to the ^{210}Po produced by the neutron capture reaction in ^{209}Bi . Gamma rays can cause film fogging and reduced contrast sensitivity. In particular, some scintillator converter screens exhibit sensitivity to beam gamma-ray contamination. This effect can be minimized by careful selection of the screen/film combination.

11. Beam Uniformity

11.1 The only true measurement of the beam uniformity is with a radiograph made without objects. Ideally the intensity of neutrons should be uniform across the entire radiograph.

11.2 A common approach for measuring the beam uniformity is to expose a film without any objects present on it to an optical density of 2.0 to 3.0. Optical density measurements are then taken at the center of the film and 25 to 30 mm towards the center from each corner of the film, and the numerical mean of these measurements calculated. If the beam diameter is smaller than the film, the four outside measurements are taken 25 to 30 mm from the edge of the beam at 90 degree intervals. A beam is considered to be uniform if the optical density does not vary by more than $\pm 5\%$ from this numerical mean.

12. Masking

12.1 *General*—In general, masking is not often used in thermal neutron radiology. Where it is desirable to reduce scatter or to reduce unusual contrasts, the choice of masking materials should be made carefully. Materials that scatter readily, such as those containing hydrogen or materials that emit radiation that may be readily detected, for example, as indium, dysprosium, or cadmium, should be avoided or used with exceptional care. Lithium-containing materials may be useful for masking purposes. Background fogging may result from the 470 keV gamma ray from boron.

13. Effect of Materials Surrounding Object and Cassette

13.1 *Backscatter*—As in the case of X-ray radiography, effects of back-scattered radiation, for example, from walls, etc., can be reduced by masking the radiation beam to the smallest practical exposure area. Effects of backscatter can be determined by placing a neutron-absorbing marker of a material such as gadolinium and a gamma-absorbing marker of a material such as lead on the back of the exposure cassette. If problems with backscatter are shown, one should minimize the exposure area materials that scatter or emit radiation as discussed in Section 4.12. Backscatter can be minimized by placing a neutron absorber such as gadolinium behind the cassette.

14. Cassettes

14.1 *Material of Construction*—The cassette frame and back may be fabricated of aluminum or magnesium as employed in standard X-ray film cassettes. Aluminum or magnesium entrance window X-ray cassettes can be used directly for neutron radiography. Special vacuum cassettes designed specifically for neutron radiography are preferred to conventional X-ray cassettes. Plastic window X-ray cassettes should not be used. The plastic entrance face may be replaced with thin, 0.25 to 1.7 mm

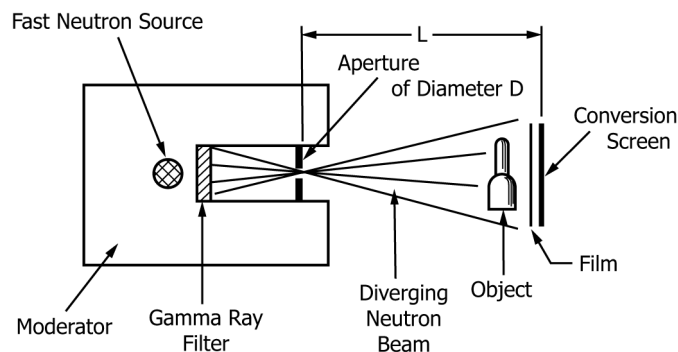

FIG. 2 Pinhole Collimator

thick 1100 reactor grade, or 6061T6 aluminum, or magnesium to eliminate image resolution degradation due to scattering; use of hydrogenous materials in the construction of a cassette can lead to image degradation and the use of these materials should be considered carefully.

14.2 *Vacuum Cassettes*—Whenever possible, vacuum cassettes should be employed to hold the converter foil or scintillator screen in intimate contact with the film both in the direct and indirect exposure methods. Cassettes of the type that maintain vacuum during the exposure or that must be pumped continuously during the exposure are equally applicable. Vacuum storage minimizes atmospheric corrosion of converters such as dysprosium and substantially increases their useful life.

15. Thermal Neutron Radiographic Image Quality

15.1 *Image Quality Indicators*—Image quality indicators for thermal neutron radiography are described in Test Method E545. The devices and methods described therein permit: (1) the measurement of beam composition, including relative thermal neutron to higher energy neutron composition and relative gamma-ray content; and (2) devices for indicating the sensitivity of detail visible on the neutron radiograph.

16. Contrast Agents

16.1 *Improved Contrast*—Contrast agents are useful in thermal neutron radiology for demonstrating improved contrast of a tagged material or component. For thermal neutron radiography even simple liquids such as water or oil can serve as effective contrast agents. Additional useful marker materials can be chosen from neutron-attenuating materials such as boron, cadmium, and gadolinium. Of course, the deleterious effect of the contrast agent employed upon the object under examination should be considered.

17. Types of Materials To Be Examined with Thermal Neutron Radiography

17.1 *General*—This section provides a categorization of applications according to the characteristics of the object being examined. The following paragraphs provide a general list of four separate categories for which thermal neutron radiographic examination is particularly useful. Additional details concerning neutron attenuation are discussed in Appendix XI.

17.2 *Detection of Similar Density Materials*—Thermal neutron radiography can offer advantages in cases of objects of similar-density materials, that can represent problems for X-radiography. Some brazing materials, such as cadmium and silver, for example, are readily shown by thermal neutron radiography. Contrast agents can help show materials such as ceramic residues in investment-cast turbine blades. Examination of castings for voids or uniformity and of cladding materials can often be accomplished with thermal neutron radiography. Material migration in solid-state electronic components, electrolyte migration in batteries, diffusion between light and heavy water, and movement of moisture through concrete are examples in which thermal neutron radiography has proved useful.

17.3 *The Detection of Low-Density Components and Materials in High-Density Containments*—This recommended category includes the examination of metal-jacketed explosive devices, location and measurement of hydrogen in cladding materials and weldments, and of moisture in assemblies, location of fluids and lubricants in metal containment systems, examination of adhesive bonds in metal parts including honeycomb, location of liquid metals in metal parts, location of corrosion products in aluminum airframe components, examination of boron-filament composites, studies of fluid migration in sealed metal systems, and the determination of poison distribution in nuclear reactor fuel rods or control plates.

17.4 *The Examination of Highly Radioactive Objects*—The technique of indirect neutron imaging is insensitive to gamma radiation in the imaging beam or from a radioactive object that could produce fogging of the film with the resulting loss in contrast sensitivity. This category of recommended examinations includes the examination of irradiated reactor fuel capsules and plates for cracking and swelling, the determination of highly enriched nuclear fuel distribution in assemblies, and the examination of weld and braze joints in irradiated subassemblies.

17.5 *Differentiation Between Isotopes of the Same Element*—Neutron attenuation is a function of the particular isotope rather than the element involved. There are certain isotopes that have either very high or very low attenuation and, therefore, are subject to detection by thermal neutron radiology. For example, it is possible to differentiate between isotopes such as ^1H and ^2H or ^{235}U and ^{238}U .

18. Activation of Objects and Exposure Materials

18.1 *Objects*—Certain objects placed in the neutron beam may be activated, depending upon the incident neutron energy, intensity and exposure time, and the material activation cross section and half-life. Therefore, objects under examination may become radioactive. In extreme cases this could produce film fogging, thereby reducing contrast. Safety is a strong consideration; radiation monitoring of objects should be performed after each exposure. Objects that exhibit a radiation level too high for handling should be set aside to allow the radiation to decay to acceptable levels. In practice, since neutron exposure times are normally short, a short decay period will usually be satisfactory.

18.2 *Cassettes*—Radiographic cassettes containing materials such as aluminum and steel can become activated, particularly on multiple exposures. Monitoring of radiation to determine safe handling levels can alleviate safety problems and minimize film