



Standard Specification for Pressure-Reducing Manifolds for Air or Nitrogen Systems¹

This standard is issued under the fixed designation F1685; the number immediately following the designation indicates the year of original adoption or, in the case of revision, the year of last revision. A number in parentheses indicates the year of last reapproval. A superscript epsilon (ϵ) indicates an editorial change since the last revision or reapproval.

1. Scope

1.1 This specification covers the design, construction, testing and operating requirements for pressure-reducing manifolds for air or nitrogen systems, referred to herein also as manifolds. The term manifold constitutes the combination of all components and piping between, and including, the inlet and outlet ports (see Fig. 1 and Fig. 2).

1.2 The values stated in inch-pound units are to be regarded as standard. The values given in parentheses are mathematical conversions to SI units that are provided for information only and are not considered standard.

1.3 *This international standard was developed in accordance with internationally recognized principles on standardization established in the Decision on Principles for the Development of International Standards, Guides and Recommendations issued by the World Trade Organization Technical Barriers to Trade (TBT) Committee.*

2. Referenced Documents

2.1 ASTM Standards:²

F992 Specification for Valve Label Plates

F1508 Specification for Angle Style, Pressure Relief Valves for Steam, Gas, and Liquid Services

F1795 Specification for Pressure-Reducing Valves for Air or Nitrogen Systems

2.2 ASME Standard:³

B1.1 Unified Inch Screw Threads

2.3 Military Standards and Specifications:⁴

MIL-STD-167-1 Mechanical Vibrations of Shipboard Equipment (Type I—Environmental and Type II—Internally Excited)

MIL-STD-740 Airborne and Structureborne Noise Measurements and Acceptance Criteria of Shipboard Equipment
MS 16142 Boss, Gasket Seal Straight Thread Tube Fitting, Standard Dimensions for

MIL-S-901 Shock Tests, H.I. (High-Impact); Shipboard Machinery, Equipment and Systems, Requirements for
MIL-F-1183 Fittings, Pipe, Cast Bronze, Silver-Brazing, General Specification for

2.4 Government Drawings:⁴

Naval Sea Systems Command (NAVSEA):

NAVSEA 803-1385884 Unions, Fittings and Adapters Butt and Socket Welding 6000 PSI, WOG and OXY (IPS)

NAVSEA 803-1385943 Unions, Silver Brazing 3000 PSI, WOG, IPS, for UT Inspection

NAVSEA 803-1385946 Unions, Bronze, Silver Brazing, WOG for UT Inspection, 1500 PSI, WOG

3. Terminology

3.1 Definitions:

3.1.1 *accuracy of regulation, n*—the amount by which the downstream pressure may vary when the manifold is set at any pressure within the required set pressure range and is subjected to any combination of inlet pressure, flow demand, and ambient temperature variations within the specified limits.

3.1.2 *bubble-tight, n*—no visible leakage over a 5-min period using either water submersion or the application of bubble fluid for detection.

3.1.3 *external leakage, n*—leakage from the manifold which escapes to atmosphere.

3.1.4 *flow rate demand, n*—the amount of flow demanded at any given time by the system downstream of the manifold.

¹ This specification is under the jurisdiction of ASTM Committee F25 on Ships and Marine Technology and is under the direct responsibility of Subcommittee F25.11 on Machinery and Piping Systems.

Current edition approved May 1, 2019. Published June 2019. Originally approved in 1996. Last previous edition approved in 2013 as F1685 – 00 (2013). DOI: 10.1520/F1685-00R19.

² For referenced ASTM standards, visit the ASTM website, www.astm.org, or contact ASTM Customer Service at service@astm.org. For *Annual Book of ASTM Standards* volume information, refer to the standard's Document Summary page on the ASTM website.

³ Available from American Society of Mechanical Engineers (ASME), ASME International Headquarters, Two Park Ave., New York, NY 10016-5990, http://www.asme.org.

⁴ Available from DLA Document Services, Building 4/D, 700 Robbins Ave., Philadelphia, PA 19111-5094, http://quicksearch.dla.mil.

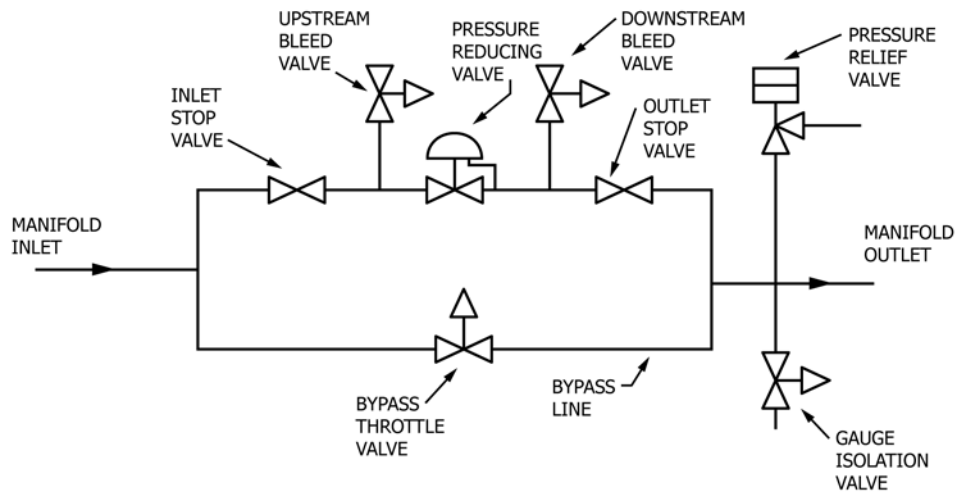

FIG. 1 Manifold Configuration

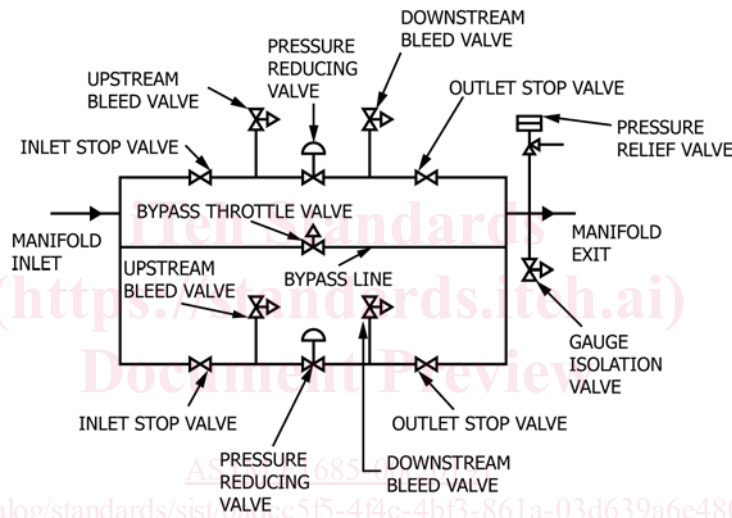

FIG. 2 Manifold Configuration

3.1.5 *flow rate demand range, n*—the range over which the flow demand can vary.

3.1.6 *hydrostatic shell test pressures, n*—the hydrostatic test pressures that the inlet and outlet sections of the manifold are required to withstand without damage. Manifold operation is not required during application of shell test pressure, but the manifold must meet all performance requirements after the shell test pressure has been removed.

3.1.7 *inlet operating pressure range, n*—the range over which the inlet pressure supplied to the manifold can vary under any operational conditions which the manifold can be subjected to in service.

3.1.8 *internal leakage, n*—leakage from higher pressure to lower pressure portions of the manifold and which does not escape to atmosphere.

3.1.9 *manifold rated pressures, n*—the inlet and outlet pressure ratings of the manifold. These rated pressures are selected from the applicable pressure ratings (see 4.2) and specified in the ordering information (see Section 5). The inlet pressure rating is applicable from the manifold inlet up to and

including the seats of the outlet stop valve and bypass throttle valve. The outlet pressure rating is applicable from the outlet side of the seats of the outlet stop valve to the manifold outlet and the bypass throttle valve to the manifold outlet.

3.1.10 *manual valves, n*—these are all the manually operated valves in the manifold which include handwheel-operated valves and wrench-operated valves. The handwheel-operated valves are the inlet and outlet stop valves, and the bypass throttle valve. The wrench-operated valves are the upstream and downstream bleed valves and the gage isolation valve. The requirements for any manually operated valves installed in the pressure-reducing valve are covered under 6.5.1.

3.1.11 *maximum flow rate demand, n*—the maximum amount of flow demanded of the manifold by the downstream system.

3.1.12 *maximum inlet operating pressure, n*—the highest pressure supplied to the inlet of the manifold in service.

3.1.13 *maximum outlet operating pressure, n*—the highest pressure at the manifold outlet in service. This is established by the accumulation pressure of the pressure-relief valve.

3.1.14 *maximum set pressure, n*—the highest set pressure at which the manifold can meet the performance requirements specified.

3.1.15 *minimum flow rate demand, n*—the minimum flow rate demanded of the manifold by the downstream system.

3.1.16 *minimum inlet operating pressure, n*—the lowest pressure supplied to the inlet of the manifold in service.

3.1.17 *minimum outlet operating pressure, n*—the lowest pressure at the manifold outlet in service. This is established by the accuracy of regulation of the pressure-reducing valve.

3.1.18 *minimum set pressure, n*—the lowest set pressure at which the manifold can meet the performance requirements specified.

3.1.19 *operating pressures, n*—the pressures within the manifold during service.

3.1.20 *pressure-reducing valve, n*—the component of the manifold which accomplishes automatic regulation of the downstream pressure. In this component, the upstream pressure is reduced to the desired downstream pressure.

3.1.21 *pressure-relief valve, n*—the component of the manifold which protects the manifold and downstream systems against downstream over pressurization.

3.1.22 *set pressure, n*—the outlet pressure delivered by the manifold at the time the pressure setting is made. For the purposes of this specification, it will be assumed that the setting is made when there is no flow demand on the manifold (“lock-up” condition), and the manifold is at surrounding ambient temperature.

3.1.23 *set pressure range, n*—the range of set pressures over which the manifold can be adjusted while meeting the performance requirements specified.

3.1.24 *wide open capacity, n*—the flow rate when a valve is in a position which presents the least resistance to flow.

4. Classification

4.1 *Configuration*—Manifolds shall be of the following configurations and specified in the ordering information (see 5.1).

Configuration 1-1 One reducer, one relief (see Fig. 1).

Configuration 2-1 Two reducers, one relief (see Fig. 2).

4.2 *Pressure Ratings*—Manifolds shall have inlet-rated pressures and outlet-rated pressures selected from the following categories: 400-, 1500-, 3000-, and 6000-psig (2.8-, 10.3-, 20.7-, and 41.4-MPa gage pressure). The inlet and outlet pressure ratings selected shall be specified in Section 5.

4.3 *End Connections*—Manifolds shall have inlet and outlet end connections selected from those listed in Table 1 and specified in Section 5.

5. Ordering Information

5.1 Ordering documentation for manifolds under this specification shall include the following information, as required, to describe the equipment adequately:

5.1.1 ASTM designation and year of issue,

TABLE 1 Manifold Inlet and Outlet End Connections

Type of End Connection	Pressure Rating, lb/in ² (MPa)	Applicable Documents
Union, ^A silver-brazed	400 (2.8)	MIL-F-1183 (O-ring type)
Union, ^A silver-brazed	1500 (10.3)	803-1385946
Union, ^A silver-brazed	3000 (20.5)	803-1385943
Union, ^A butt/socket weld	6000 (41.4)	803-1385884
As specified	As specified	As specified

^A Only the pertinent dimensions listed in the applicable documents applicable to the straight thread portion of the thread piece shall apply. Thread pieces shall be secured to the manifold inlet and outlet blocks using straight threads and a O-ring seal design. For the manifold inlet and outlet connections, unless otherwise specified in Section 5 the tail pieces and the union nuts shall not be furnished—only the thread pieces shall be furnished. If tail pieces and union nuts are required, their materials of construction shall be in accordance with the applicable documents listed above and shall be specified in Section 5.

5.1.2 Size and type of inlet end connection (see 4.3 and 6.4.2),

5.1.3 Size and type of outlet end connection (see 4.3 and 6.4.2),

5.1.4 Size and type of end connections for pressure-reducing valve and pressure-relief valve,

5.1.5 If tail pieces and union nuts are required (when required, their material of construction shall be in accordance with Table 1),

5.1.6 Manifold configuration, inlet and outlet pressure ratings (see 4.1 and 4.2),

5.1.7 Manifold inlet operating pressure range,

5.1.8 Type of mounting required: bottom or back mounting (see 6.4.3),

5.1.9 Set pressure and set pressure range, if other than specified (see 7.3),

5.1.10 Flow rate demand range (see 7.1, S1.1.6),

5.1.11 Accuracy of regulation required, if other than specified, or if set pressure is below 10 psig (see 7.2),

5.1.12 Relief valve set pressure and accumulation pressure (if different from Specification F1508),

5.1.13 Ambient atmospheric conditions: temperature range, chemical contaminants, if any,

5.1.14 Quality of inlet air/nitrogen gas: temperature range, moisture content, oil/lubricant contaminants, if any,

5.1.15 Special tools required (see 6.7),

5.1.16 Tamper-proof lead seal if required (see Specification F1795, Section 5),

5.1.17 Supplementary requirements, if any (S1 through S4), and

5.1.18 Maximum vibration frequency, if other than specified (see S1.1.9).

6. Manifold Construction

6.1 Manifolds shall incorporate the design features specified in 6.2 – 6.11.

6.2 *Materials of Construction*—Material requirements for the assemblies in the manifold shall be as specified in the applicable component specifications referenced herein. Materials for all other parts, including the inlet and outlet manifold blocks, shall be 300 series corrosion-resistant steel (SS304, 304L, 316, or 316L) or other materials selected to provide

weldability and corrosion resistance without requiring painting, coating, or plating. The inlet and outlet manifold blocks shall be weld repairable. Materials for contacting parts shall be selected to minimize electrolytic corrosion and galling. Metallic materials shall conform to applicable ASTM specifications. Nonmetallic materials shall be compatible with the line medium.

6.3 *General Requirements*—Manifolds shall incorporate the functional elements shown schematically in Fig. 1 or Fig. 2, as applicable, and delineated below:

- (1) Inlet and outlet stop valves,
- (2) Upstream and downstream bleed valves (for depressurization of all components and fluid cavities),
- (3) Pressure-reducing valve(s),
- (4) Pressure-relief valve,
- (5) Gauge isolation valve, and
- (6) Bypass throttle valve.

All components shall be part of a manifold assembly, as shown in Fig. 3 or Fig. 4, as applicable, which requires only one inlet and one outlet connection to the main flow path of the piping system in which it is installed. The inlet and outlet connections shall be in-line. The manifold shall be fabricated from inlet and outlet blocks, with interconnecting piping for the pressure-reducing valve(s) and bypass throttle valve flow paths. The manual valves shall be cartridge mounted into the inlet and outlet manifold blocks as shown in Fig. 3 or Fig. 4, as applicable. The pressure-reducing valve and the pressure-relief valve shall be mounted by way of takedown connections in accordance with Table 1. The manifold shall be capable of meeting all requirements of this specification and provide extended reliable operation when protected by a 5- μm nominal/18- μm absolute filter installed upstream of the manifold inlet and when subjected to conditions specified in Section 5.

6.4 *Design Construction Requirements:*

6.4.1 *Pressure Envelope*—The hydrostatic shell test pressures shall be 1.5 times the manifold rated inlet and outlet pressures.

6.4.2 *Connections*—The main-line inlet and outlet connections of the manifold, the inlet and outlet connections of the pressure-reducing valve(s), the connections for the bypass line, and the inlet and outlet connection to the pressure-relief valve shall be takedown joints (unions or other as specified) as specified in Table 1 based on rated pressures specified. Any exposed threads shall be protected by plastic caps for shipping. The main-line inlet and outlet connection of the manifold and the inlet and outlet connection for the pressure-reducing valve(s) shall permit axial adjustment to expedite proper installation of the manifold into the piping system and to facilitate replacement of the pressure-reducing valve(s) with one of another make or model or which is for some other reason not dimensionally identical to the originally installed pressure-reducing valve(s). The axial adjustment feature for the pressure-reducing valve(s) shall be included in that portion of the takedown joints that are connected to the inlet and outlet manifold blocks. If unions in accordance with Table 1 are specified for the pressure-reducing valve(s) inlet and outlet connections, the thread pieces shall be the portions of the unions that are attached to the pressure-reducing valve(s). The range over which each of the four adjustable connections noted above can be adjusted shall be as specified in Table 2. A positive and permanent means shall be incorporated to ensure that none of the four adjustable connections can be backed out beyond their minimum engagement position. The size of the main-line inlet and outlet connections of the manifold shall be as specified (see Section 5).

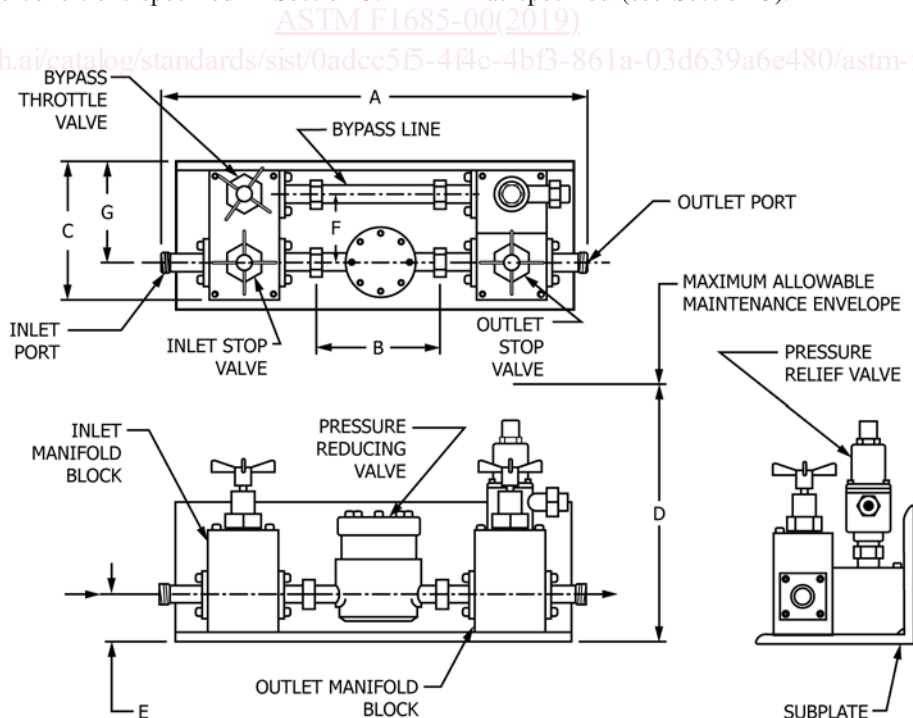

NOTE 1—Pictorial representations are for illustrative purposes only and do not imply design.

FIG. 3 Components of a Manifold Assembly

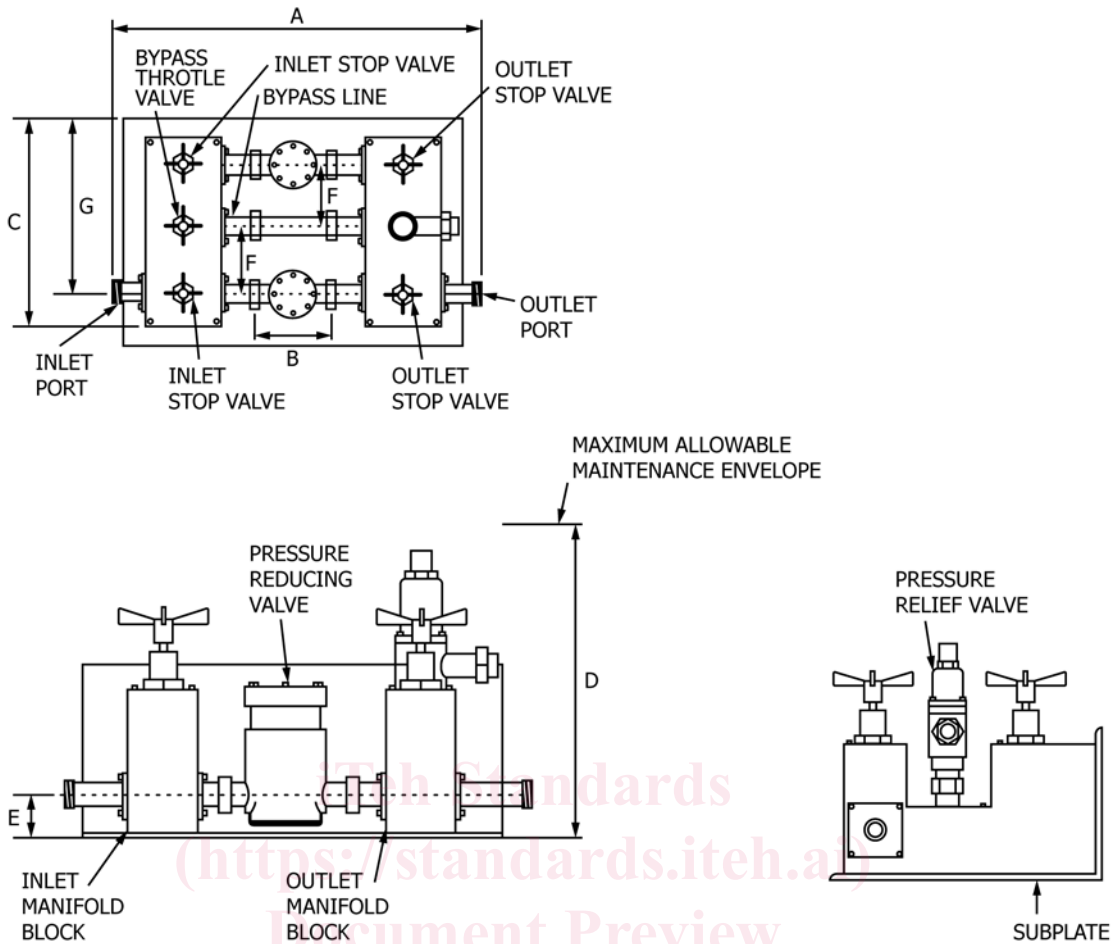

FIG. 4 Components of Manifold Assembly

TABLE 2 Adjustable Range of End Connections

Connection Size Nominal Pipe Size NPS (Dimension Nominal DN)	Minimum Adjustment Range of Each Connection, in. (mm)
1/4 and 3/8 (8 and 10)	3/8 (10)
1/2, 3/4, 1, and 1 1/4 (15, 20, 25, and 32)	1/2 (13)
1 1/2 and 2 (40 and 50)	3/4 (19)

6.4.3 *Manifold Mounting*—The manifold shall be given structural integrity by means of a subplate provided as part of the manifold. The subplate shall be an angle form to provide an accurate mounting surface for both back and bottom mounting and shall be bolted to the inlet and outlet manifold blocks in such a way as to not interfere with mounting the manifold to a foundation plate. The manifold shall be drilled and tapped or through-drilled to allow either bottom mounting or back mounting as specified (see Section 5). All components shall be fully and easily accessible for operation, service, or removal from the manifold.

6.4.4 *Threads*—Threads shall be as specified in ASME B1.1. Where necessary, provisions shall be incorporated to prevent the accidental loosening of threaded parts. The design shall be such that standard wrenches can be used on all external bolting. Lock wire shall not be used.

6.4.5 *Interchangeability*—The entire manifold, including components and all associated piece parts, shall have part number identity and shall be replaceable from stock or the manufacturer on a nonselective and random basis. Parts having the same manufacturer’s part number shall be directly interchangeable with each other with respect to installation (physical) and performance (function). Physically interchangeable assemblies, components, and parts are those that are capable of being readily installed, removed, or replaced without alteration, misalignment, or damage to parts being installed or to adjoining parts. Fabrication operations such as cutting, filing, drilling, reaming, hammering, bending, prying, or forcing shall not be required.

6.4.6 *Nonmetallic Element Interchangeability*—Nonmetallic elements, including but not limited to, seat rings, poppet seat inserts, cushions, and O-rings, shall be treated as separately identified and readily replaceable parts.

6.4.7 *Pressure Gage*—The manifold shall be provided with a 1/4-in. (DN 8) threaded gage connection port to permit attachment of a pressure gage for sensing the outlet pressure. The gage connection under all operating conditions shall be located to measure accurately pressure at the manifold outlet connection when using either the pressure-reducing valve or the bypass throttle valve to control flow. A gage isolation valve shall be provided in the manifold.

6.4.8 *Bleed Valves*—Bleed valves as shown in Fig. 1 and Fig. 2 shall be provided to allow depressurization of piping and components.

6.5 *Component Requirements:*

6.5.1 *Pressure-Reducing Valve*—Pressure-reducing valve(s) incorporated in the manifold shall be in accordance with Specification F1795, Type I construction. The pressure rating shall be in accordance with 4.2 and shall equal the manifold inlet pressure rating.

6.5.1.1 *Pressure Reversal*—The manifold shall withstand, without damage, a condition in which the pressure-reducing valve is subjected to a maximum reverse pressure differential. This can occur where the maximum set pressure exists at the pressure-reducing valve outlet, the pressure-reducing valve loading element is deactivated (that is, if it is a spring-loaded, pressure-reducing valve, the set spring adjustment is backed off fully; and if a gas-dome loaded pressure-reducing valve, the dome charge is vented off completely), and inlet pressure is vented off.

6.5.2 *Pressure-Relief Valve*—The requirements and definitions for the pressure-relief valve incorporated in the manifold shall be as specified in Specification F1508.

6.5.3 *Manual Valves*—The requirements for the manual valves incorporated in the manifold shall be as specified in 6.5.3.1 – 6.5.3.6.

6.5.3.1 *Mounting*—All manual valves shall be cartridge mounted into the manifold blocks.

6.5.3.2 *Seats*—Each manual valve shall incorporate a non-metallic seating feature for tight shutoff.

6.5.3.3 *Handwheel Operating Force*—For hand-operated valves, the maximum permissible total tangential force required on the rim of the handwheel for operating, or seating/unseating the valves shall not exceed 50 lbs (220 N) when the valve is subjected to the maximum operating pressure.

6.5.3.4 *Bidirectional Shutoff*—All manual valves shall be capable of operation and tight shutoff when pressure is applied in either direction.

6.5.3.5 *Pressurization Rate*—All manual valves shall be capable of being operated to limit the rate of downstream

pressure buildup in a depressurized volume (with maximum pressure upstream) to 200-psig (1379-KPa gage pressure) per second. Downstream volumes for this pressurization rate requirement shall be taken as the applicable manifold volumes. For design and test purposes, a stop valve not more than ten diameters downstream of the manifold outlet connection shall be assumed.

6.5.3.6 *Bypass Throttle Valve*—The bypass throttle valve shall be sized to pass full-rated flow of the manifold and control the outlet pressure at all flow demands and inlet pressures within the range of the manifold.

6.6 *Manifold Envelope Dimensions*—Manifold envelope dimensions shall be as specified in Fig. 3 or Fig. 4 and Table 3, as applicable.

6.7 *Maintainability*—The manifold shall permit direct access for disassembly, repair, and reassembly of all internal working parts and subassemblies when mounted for operation on its subplate and installed into the system. Maintenance shall require standard tools to the maximum extent possible. Any special tools required for maintenance shall be identified and shall be supplied when ordered (see Section 5).

6.8 *Reversibility*—Seating inserts shall not be physically reversible unless they are also functionally reversible to preclude incorrect assembly.

6.9 *Adjustments*—There shall be no adjustments required in the manifold during or after assembly other than the axial positioning of the takedown connections for installation of the pressure-reducing valve into the manifold or installation of the manifold into the system and the set points of the pressure-reducing valve and the pressure-relief valve.

6.10 *Reliability*—Periodic maintenance of the manifold or any of its components shall not be required. There shall be no postassembly lubrication required.

6.11 *Ruggedness*—To the maximum extent practical, the manifold and its components shall be designed to prevent damage, malfunction, or leakage as a result of foreign particle or other line media contamination or from mishandling.

TABLE 3 Envelope Dimensions of Manifolds

Manifold Size (Inlet x Outlet), in. (DN Metric)	Distance Between Takedown Joints (At Adj Mid-Pt)		C ±0.12 in. Configuration 1–1 (±3 mm)	C ±0.12 Configuration 2–1 (±3 mm)	D (Max) in. (mm)	E ±0.06 in. (±2 mm)	F Min (mm)	G ±0.06 (±2 mm)
	A ±0.12 in. (±3 mm)	B ±0.12 in. (±3 mm)						
1/4 x 1/4 (DN 8 x 8)	19 (483)	6 1/4 (159)	6 1/2 (165)	9 1/2 (241)	12 (305)	4 (102)	3 1/2 (89)	5 (127)
1/4 x 1/2 (DN 8 x 15)	19 1/2 (495)	6 1/2 (165)	7 (178)	10 1/4 (260)	12 1/4 (311)	4 1/4 (108)	3 3/4 (95)	5 5/8 (137)
1/4 x 3/4 (DN 8 x 20)	20 (508)	6 3/4 (171)	7 1/2 (191)	10 1/4 (260)	12 1/2 (318)	4 1/2 (114)	4 (102)	6 1/8 (156)
3/8 x 3/8 (DN 10 x 10)	21 (533)	7 (178)	8 (203)	11 1/2 (292)	13 (330)	4 3/4 (121)	4 1/2 (114)	6 1/4 (159)
3/8 x 1/2 (DN 10 x 15)	21 1/2 (546)	7 1/4 (184)	8 1/2 (216)	12 1/4 (311)	13 1/4 (337)	5 (127)	4 3/4 (121)	6 5/8 (169)
3/8 x 3/4 (DN 10 x 20)	22 (559)	7 1/2 (191)	9 (229)	13 (330)	13 1/2 (343)	5 1/4 (133)	5 (127)	7 (178)
1/2 x 1/2 (DN 15 x 15)	23 (584)	8 (203)	9 1/2 (241)	14 (356)	14 (356)	5 1/2 (140)	5 (127)	7 1/4 (184)
1/2 x 3/4 (DN 15 x 20)	23 1/2 (597)	8 1/4 (210)	10 (254)	14 3/4 (375)	14 1/4 (362)	5 3/4 (146)	5 1/4 (133)	7 5/8 (194)
1/2 x 1 (DN 15 x 25)	24 (610)	9 1/2 (241)	10 1/2 (267)	15 1/2 (394)	14 1/2 (368)	6 (152)	5 1/2 (140)	8 (203)
3/4 x 3/4 (DN 20 x 20)	25 (635)	9 (229)	11 (279)	16 1/2 (419)	15 (381)	6 1/4 (159)	5 (146)	8 1/4 (210)
3/4 x 1 (DN 20 x 25)	25 1/2 (648)	9 1/4 (235)	11 1/2 (292)	17 1/4 (438)	15 1/4 (387)	6 1/2 (165)	6 (152)	8 5/8 (219)
3/4 x 1 1/4 (DN 20 x 32)	26 (660)	9 1/2 (241)	12 (305)	18 (457)	15 1/2 (394)	6 3/4 (171)	6 1/4 (159)	9 (229)
3/4 x 1 1/2 (DN 20 x 40)	26 (660)	9 1/2 (241)	12 (305)	18 (457)	15 1/2 (394)	6 3/4 (171)	6 1/4 (159)	9 (229)
1 x 1 (DN 25 x 25)	27 (686)	10 (254)	12 1/2 (318)	18 1/2 (470)	16 (406)	7 (178)	6 1/2 (165)	9 1/2 (241)
1 x 1 1/4 (DN 25 x 32)	27 1/2 (699)	10 1/4 (260)	13 (330)	19 1/4 (489)	16 1/4 (413)	7 1/4 (184)	6 (171)	9 7/8 (251)
1 x 1 1/2 (DN 25 x 40)	27 1/2 (699)	10 1/4 (260)	13 (330)	19 1/4 (489)	16 1/4 (413)	7 1/4 (184)	6 3/4 (171)	9 7/8 (251)
1 x 2 (DN 25 x 50)	28 (711)	10 1/2 (267)	13 1/2 (343)	19 1/2 (495)	16 1/2 (419)	7 1/2 (191)	7 (178)	10 1/2 (267)