



Standard Specification for Stuffing Tubes, Nylon, and Packing Assemblies (Metric)¹

This standard is issued under the fixed designation F1836M; the number immediately following the designation indicates the year of original adoption or, in the case of revision, the year of last revision. A number in parentheses indicates the year of last reapproval. A superscript epsilon (ϵ) indicates an editorial change since the last revision or reapproval.

This standard has been approved for use by agencies of the U.S. Department of Defense.

1. Scope

1.1 This specification covers the general requirements for nylon stuffing tubes and packing assemblies. Nylon stuffing tubes are intended for making electric cable penetrations in marine shipboard enclosures for electrical equipment. The following types are suitable for both thin-wall enclosures up to 5 mm ($3/16$ in.) thick and thick-wall enclosures, bulkheads, and decks of 5 to 19 mm ($3/16$ to $3/4$ in.) thick.

1.2 This specification does not cover metal stuffing tubes.

1.3 The values stated in SI units are to be regarded as standard. No other units of measurement are included in this standard.

1.4 *This standard does not purport to address all of the safety concerns, if any, associated with its use. It is the responsibility of the user of this standard to establish appropriate safety, health, and environmental practices and determine the applicability of regulatory limitations prior to use.*

1.5 *This international standard was developed in accordance with internationally recognized principles on standardization established in the Decision on Principles for the Development of International Standards, Guides and Recommendations issued by the World Trade Organization Technical Barriers to Trade (TBT) Committee.*

2. Referenced Documents

2.1 *ASTM Standards:*²

[D2000 Classification System for Rubber Products in Automotive Applications](#)

¹ This specification is under the jurisdiction of ASTM Committee F25 on Ships and Marine Technology and is the direct responsibility of Subcommittee F25.10 on Electrical.

Current edition approved May 1, 2019. Published June 2019. Originally approved in 1997. Last previous edition approved in 2015 as F1836M – 15. DOI: 10.1520/F1836M-15R19.

² For referenced ASTM standards, visit the ASTM website, www.astm.org, or contact ASTM Customer Service at service@astm.org. For *Annual Book of ASTM Standards* volume information, refer to the standard's Document Summary page on the ASTM website.

[D4066 Classification System for Nylon Injection and Extrusion Materials \(PA\)](#)

2.2 *NEMA Standard:*³

[Standard 250 Enclosures for Electrical Equipment \(1000 V Max\)](#)

2.3 *ASME Standard:*⁴

[ASME B1.1 Unified Inch Screw Threads \(UN and UNR Thread Form\)](#)

2.4 *IEC Standard:*⁵

[Standard 68-2-6 Environmental Testing—Part 2: Tests—Test FC: Vibration \(Sinusoidal\) Sixth Edition](#)

3. Terminology

3.1 *Definitions of Terms Specific to This Standard:*

3.1.1 *nylon stuffing tube, n*—a marine electrical fitting used for the sealing of cable penetration into shipboard enclosures while maintaining or exceeding the degree of protection for which the enclosure is rated.

3.1.2 *packing assembly, n*—the compressible insert for the nylon stuffing tube. It consists of one neoprene bushing and three nylon washers.

3.1.3 *enclosure, n*—an electrical panel, cabinet, junction box, light fixture, electrical equipment, control box, or panel.

4. Classification

4.1 Nylon stuffing tubes shall be of the following types (see Fig. 1):

4.1.1 *Type 1*—straight—Unified Form Thread.

4.1.2 *Type 2*—90°—Unified Form Thread.

4.1.3 *Type 3*—NPT—American Standard Pipe Thread.

4.1.4 *Type 4*—Y—Unified Form Thread.

³ Available from National Electrical Manufacturers Association (NEMA), 1300 N. 17th St., Suite 900, Arlington, VA 22209, <http://www.nema.org>.

⁴ Available from American Society of Mechanical Engineers (ASME), ASME International Headquarters, Two Park Ave., New York, NY 10016-5990, <http://www.asme.org>.

⁵ Available from International Electrotechnical Commission (IEC), 3, rue de Varembe, 1st floor, P.O. Box 131, CH-1211, Geneva 20, Switzerland, <https://www.iec.ch>.

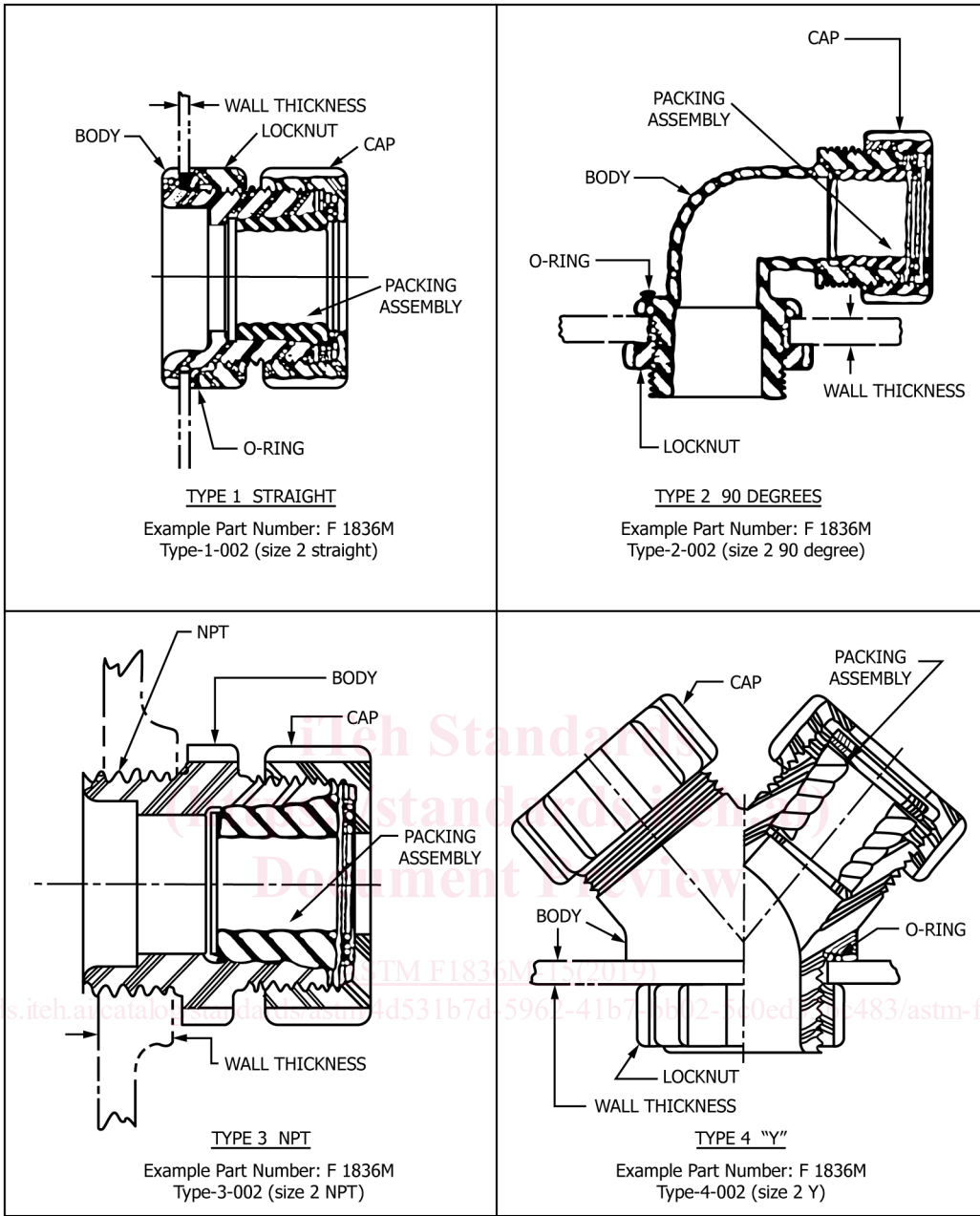

FIG. 1 Stuffing Tube Types

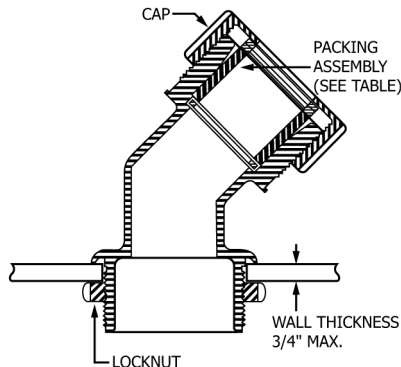

FIG. 1 Stuffing Tube Types (continued)

5. Ordering Information

5.1 Orders for stuffing tubes under this specification shall include the following:

- 5.1.1 Type (see 4.1).
- 5.1.2 Part number (see Table 1).
- 5.1.3 Packing assembly size (see Fig. 2 and Table 2).
- 5.1.4 The O-ring included in the stuffing tube assembly has a finite shelf life. If the stuffing tube assembly is used after the shelf life has expired, the O-ring should be replaced, using the appropriate size listed in Table 1.

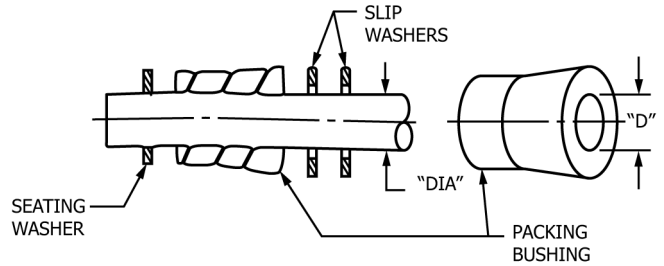

FIG. 2 Typical Packing Assembly

TABLE 1 Stuffing Tubes Part Numbers and Dimensional Data

Tube Size	Part No.	Cable Range				Packing Assembly ^A	Clearance Hole Diameter for Tube Install		O-Ring Buna-N Size	
		in.		mm			in.	mm		
		min.	max.	min.	max.					
Straight Type 1	Type-1-001	0.077	0.300	1.96	7.62	-16	0.885	22.48	212	
	-002	0.275	0.472	6.99	11.99	-17	1.010	25.65	214	
	-003	0.410	0.472	10.41	11.99	-18	1.135	28.83	216	
	-004	0.450	0.777	11.43	19.74	-19	1.260	32.00	218	
	4T	-005	0.450	0.777	11.43	19.74	-19	1.385	35.18	220
	-006	0.752	1.113	19.10	28.27	-20	2.010	51.05	226	
	-007	0.806	1.390	20.47	35.31	-21	2.510	63.75	230	
	-008	1.433	1.610	36.40	40.89	-22	2.760	70.10	232	
	-009	1.625	2.00	41.28	50.80	-23	3.260	82.80	236	
-010	2.030	2.700	51.56	68.58	-24	4.010	101.85	242		
90° Type 2	Type-2-001	0.077	0.300	1.96	7.62	-16	0.885	22.48	212	
	-002	0.275	0.472	6.99	11.99	-17	0.885	22.48	212	
	-003	0.410	0.472	10.41	11.99	-18	1.135	28.83	216	
	4T	-005	0.450	0.777	11.43	19.74	-19	1.260	32.00	218
	-006	0.752	1.113	19.10	28.27	-20	2.010	51.05	220	
	-007	0.806	1.390	20.47	35.31	-21	2.510	63.75	230	
NPT Type 3	Type-3-001	0.077	0.300	1.96	7.62	-16	0.5			
	-002	0.275	0.472	6.99	11.99	-17	0.75			
	-003	0.410	0.472	10.41	11.99	-18	1.0			
	4T	-004	0.450	0.777	11.43	19.74	-19	1.0		
	-005	0.752	1.113	19.10	28.27	-20	1.5			
	-006	0.806	1.390	20.47	35.31	-21	2			
	-007	1.433	1.610	36.40	40.89	-22	2.5			
	-008	1.625	2.00	41.28	50.80	-23	3			
	-009	2.030	2.700	51.56	68.58	-24	3.5			
Y Type 4	Type-4-001	0.077	0.300	1.96	7.62	-16	0.885	22.48	212	
	-002	0.275	0.472	6.99	11.99	-17	1.010	25.65	214	
	-003	0.410	0.472	10.41	11.99	-18	1.135	28.83	216	
	4T	-004	0.450	0.777	11.43	19.74	-19	1.385	35.18	220
NYST Type 5	Type-5-001-004									
	-005	0.752	1.113	19.10	28.27	-20	2.010	51.05		
	-006	0.806	1.390	20.47	35.31	-21	2.510	63.75		

^A See Table 2 size selection.